

1.5MHz, 3A Synchronous Step-Down DC/DC Converter

FEATURES

- High Efficiency: Up to 95%
- 1.5MHz Constant Frequency Operation
- 3A Output Current
- No Schottky Diode Required
- 2.3V to 6V Input Voltage Range
- Output Voltage as Low as 0.6V
- Low Quiescent Current: 40 μ A
- 100% Duty Cycle in Dropout Operation
- PFM Mode for High Efficiency in Light Load
- Slope Compensated Current Mode Control for Excellent Line and Load Transient Response
- Inrush Current Limit and Soft Start
- <1 μ A Shutdown Current
- Available in ESOP-8 package

APPLICATIONS

- Cable/DSL Modems
- Computer Peripherals
- Network Cards
- High Efficiency Conversion from 5V or 3.3 Supply
- Set-Top Boxes

GENERAL DESCRIPTION

The HM3430 is a constant frequency, current mode step-down converter. The device integrates a main switch and a synchronous rectifier for high efficiency without an external Schottky diode. It is ideal for powering portable equipment that runs from a single cell Lithium-Ion (Li+) battery. The HM3430 can supply up to 3A output load current from a 2.3V to 6V input voltage and the output voltage can be regulated as low as 0.6V. The HM3430 can also run at 100% duty cycle for low dropout operation, extending battery life in portable systems while light load operation provides very low output ripple for noise sensitive applications. The internal slope compensation setting allows the device to operate with smaller inductor values to optimize size and provide efficient operation. The HM3430 is available in adjustable (0.6V to VIN) output voltage.

This device offers two operation modes, PWM control and PFM Mode switching control, which allows a high efficiency over the wider range of the load.

TYPICAL APPLICATION

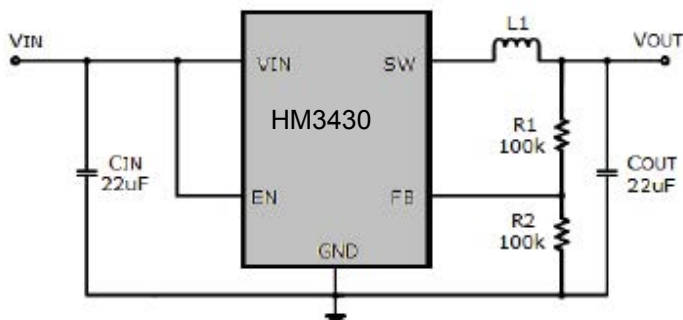
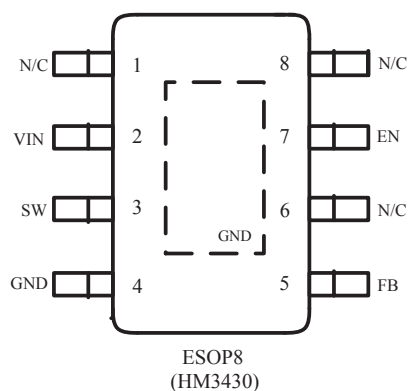

Figure 1. Basic Application Circuit

PIN DESCRIPTION

PIN	NAME	FUNCTION
1,6,8	N/C	No Connect.
2	Vin	Power Supply Input. Must be closely decoupled to GND with a 22 μ F or greater ceramic capacitor.
3	SW	Power Switch Output. It is the switch node connection to Inductor. This pin connects to the drains of the internal P-ch and N-ch MOSFET switches.
4	GND	Ground pin.
5	FB	Output Voltage Feedback Pin. An internal resistive divider divides the output voltage down for comparison to the internal reference voltage.
7	EN	Chip Enable Pin. Drive EN above 1.5V to turn on the part. Drive EN below 0.4V to turn it off. Do not leave EN floating.
	EP	Power Ground exposed pad, Must be connected to bare copper ground plane

PACKAGE INFORMATION



Part Number	SWICHING FREQUENCY	Temp Range	OUTPUT VOLTAGE (V)	OUTPUT CURRENT (A)
HM3430	1.5MHz	-40°C to +85°C	ADJ	3

ABSOLUTE MAXIMUM RATINGS

Input Supply Voltage -0.3V to 6.5V
 EN,FB Voltages.....-0.3 to (Vin+0.3V)
 SW Voltage-0.3V to (Vin+0.3V)

Operating Temperature Range ... -40°C to +85°C
 Lead Temperature(Soldering,10s)+300°C
 Storage Temperature Range-65°C to 150°C

ELECTRICAL CHARACTERISTICS

($V_{IN}=V_{EN}=3.6V$, $V_{OUT}=1.8V$, $T_A = 25^\circ C$, unless otherwise noted.)

Parameter	Conditions	MIN	TYP	MAX	unit
Input Voltage Range		2.3		6	V
UVLO Threshold		1.7	1.8	1.9	V
Input DC Supply Current					μA
PWM Mode	$V_{out} = 90\%$, $I_{load}=0mA$		160	240	μA
PFM Mode	$V_{out} = 105\%$, $I_{load}=0mA$		40	70	μA
Shutdown Mode	$V_{EN} = 0V$, $V_{IN}=4.2V$		0.1	1.0	μA
Regulated Feedback Voltage	$T_A = 25^\circ C$	0.582	0.600	0.618	V
Reference Voltage Line Regulation	$V_{in} = 2.7V$ to $5.5V$		0.04	0.40	%/V
Output Voltage Line Regulation	$V_{IN} = 2.7V$ to $5.5V$		0.04	0.4	%
Output Voltage Load Regulation			0.5		%
Oscillation Frequency	$V_{out}=100\%$		1.5		MHz
	$V_{out}=0V$		300		kHz
On Resistance of PMOS	$I_{SW}=100mA$		0.09	0.15	Ω
ON Resistance of NMOS	$I_{SW}=-100mA$		0.08	0.15	Ω
Peak Current Limit	$V_{IN} = 3V$, $V_{out}=90\%$		4		A
EN Threshold		0.40	1.0	1.50	V
EN Leakage Current			± 0.01	± 0.1	μA
SW Leakage Current	$V_{EN}=0V$, $V_{IN}=V_{sw}=3.6V$		± 0.01	± 1.0	μA

TYPICAL PERFORMANCE CHARACTERISTICS

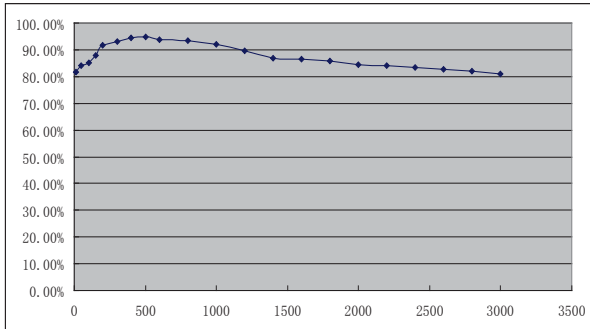

Vin=5V, Vout=1.8V

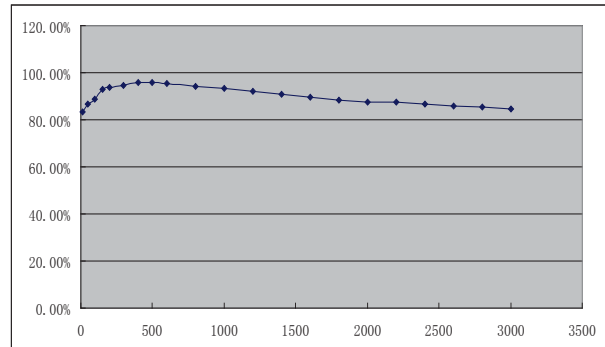

Vin=5V, Vout=3.3V

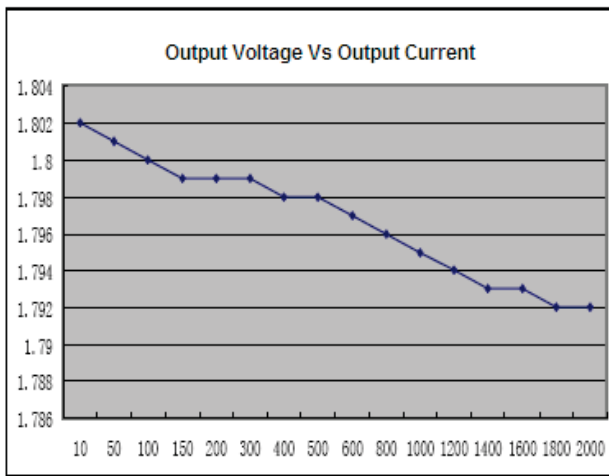

Vin=3.6V, Vout=1.8V

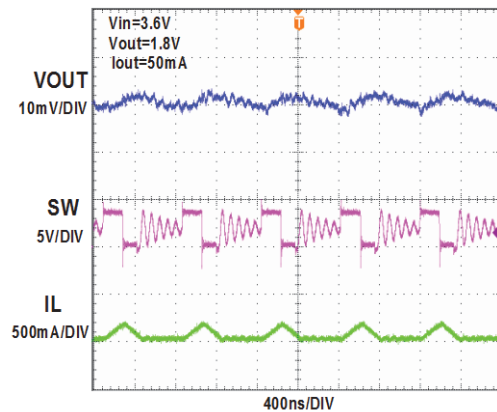
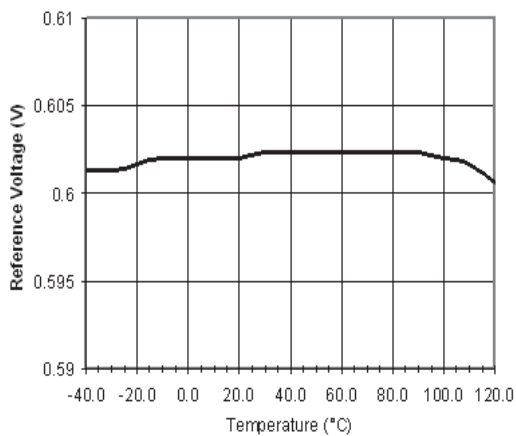
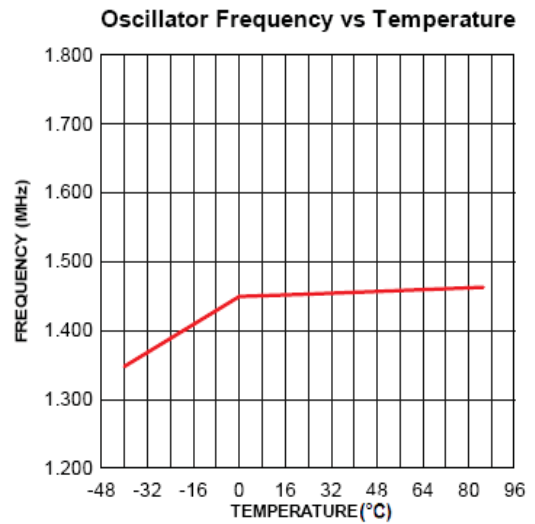

PFM MODE

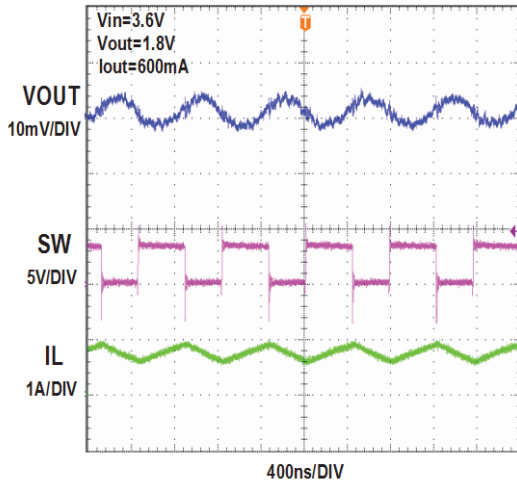

PWM MODE

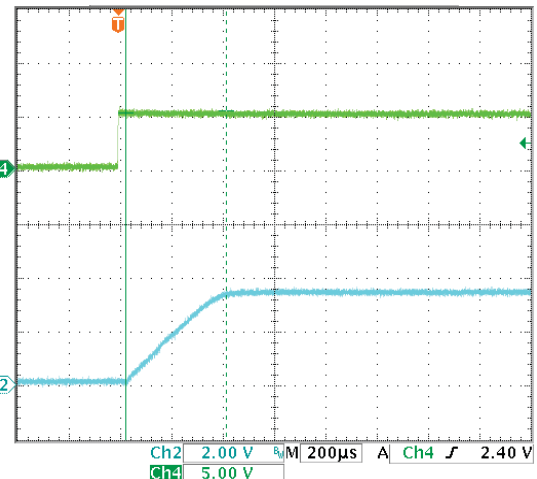

Start up

FUNCTIONAL BLOCK DIAGRAM

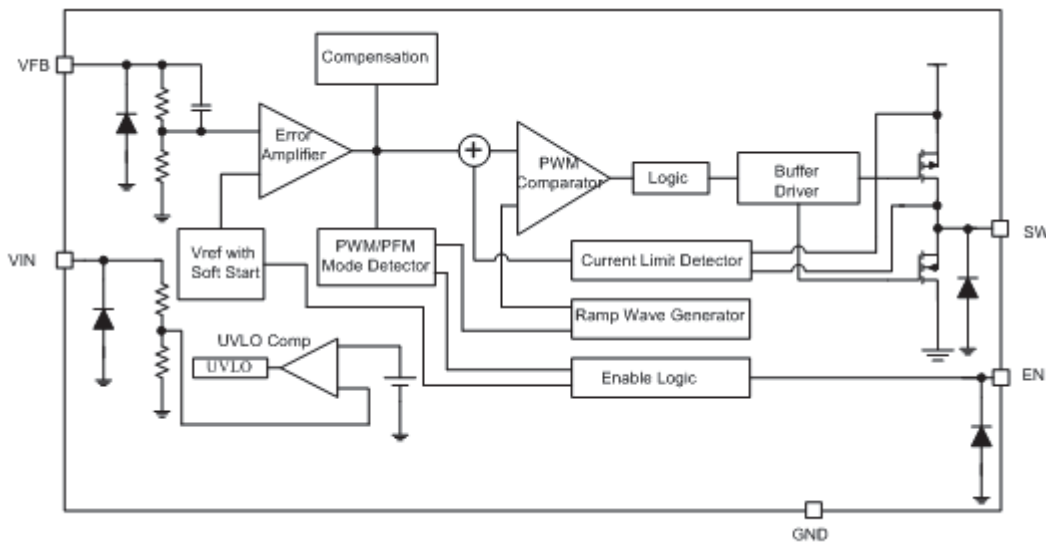

Figure 2. HM3430 Block Diagram

FUNCTIONAL DESCRIPTION

The HM3430 is a high performance 3A 1.5MHz monolithic step-down converter. The HM3430 requires only three external power components (C_{in} , C_{out} and L). The adjustable V_{out} can be programmed with external feedback to any voltage, ranging from 0.6V to the input voltage.

At dropout operation, the converter duty cycle increases to 100% and the output voltage tracks the

input voltage minus the R_{dson} drop of the high-side MOSFET.

The internal error amplifier and compensation provides excellent transient response, load, and line regulation. Soft start function prevents input inrush current and output overshoot during start up.

APPLICATIONS INFORMATION

Inductor Selection

For most designs, the HM3430 operates with inductors of 1μH to 4.7μH. Low inductance values are physically smaller but require faster switching, which results in some efficiency loss. The inductor value can be derived from the following equation:

$$L = \frac{V_{OUT} \times (V_{IN} - V_{OUT})}{V_{IN} \times \Delta I_L \times f_{OSC}}$$

Where ΔI_L is inductor Ripple Current. Large value inductors result in lower ripple current and small value inductors result in high ripple current. For optimum voltage-positioning load transients, choose an inductor with DC series resistance in the 20mΩ to 100mΩ range.

Vout	1.2V	1.5V	1.8V	2.5V	3.3V
L	1.2uH	1.5uH	2.2uH	2.2uH	4.7uH

Input Capacitor Selection

The input capacitor reduces the surge current drawn from the input and switching noise from the device. The input capacitor impedance at the switching frequency should be less than input source impedance to prevent high frequency switching current passing to the input. A low ESR input capacitor sized for maximum RMS current must be used. Ceramic capacitors with X5R or X7R dielectrics are highly recommended because of their low ESR and small temperature coefficients. A 22μF ceramic capacitor for most applications is sufficient. A large value may be used for improved input voltage filtering.

Output Capacitor Selection

The output capacitor is required to keep the output voltage ripple small and to ensure regulation loop stability. The output capacitor must have low impedance at the switching frequency. Ceramic capacitors with X5R or X7R dielectrics are recommended due to their low ESR and high ripple current ratings. The output ripple ΔV_{OUT} is determined by:

$$\Delta V_{OUT} \leq \frac{V_{OUT} \times (V_{IN} - V_{OUT})}{V_{IN} \times f_{OSC} \times L} \times \left(ESR + \frac{1}{8 \times f_{osc} \times C3} \right)$$

A 22μF ceramic can satisfy most applications.

Setting the Output Voltage

The internal reference is 0.6V (Typical). The output voltage is calculated as below:

$$V_{out} = 0.6 \times (1 + R1/R2)$$

The output voltage is given by Table1:

Vout	R1	R2
1.2V	100K	100K
1.5V	150K	100K
1.8V	200K	100K
2.5V	380K	120K
3.3V	540K	120K

Table1: Resistor selection for output voltage setting

100% Duty Cycle Operation

As the input voltage approaches the output voltage, the converter turns the P-channel transistor continuously on. In this mode the output voltage is equal to the input voltage minus the voltage drop across the

P- channel transistor:

$$V_{out} = V_{in} - I_{Load} \times (R_{dson} + R_L)$$

PCB Layout Recommendations

When laying out the printed circuit board, the following checking should be used to ensure proper operation of the HM3430. Check the following in your layout:

1. The power traces, consisting of the GND trace, the SW trace and the VIN trace should be kept short, direct and wide.
2. Does the (+) plates of C_{in} connect to V_{in} as closely as possible. This capacitor provides the AC current to the internal power MOSFETs.
3. Keep the switching node, SW, away from the sensitive VOUT node.
4. Keep the (-) plates of C_{in} and C_{out} as close as possible

PACKAGE DESCRIPTION

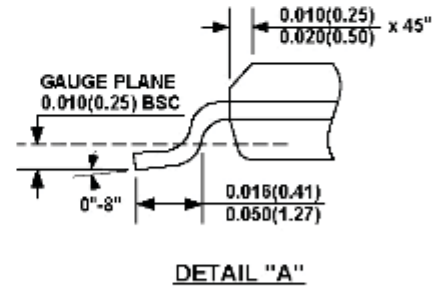
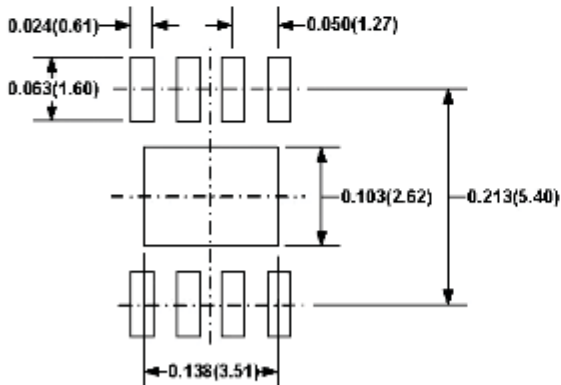
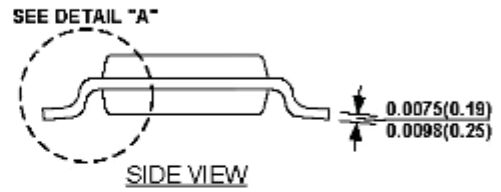
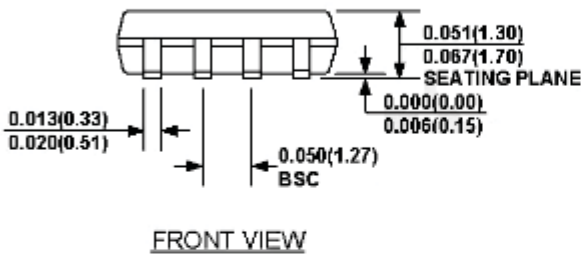
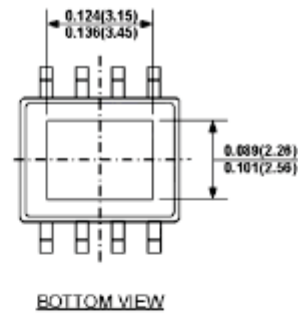
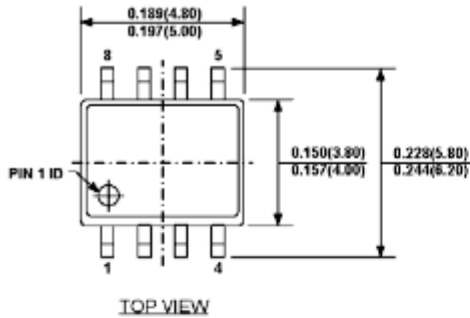

NOTE:

- 1) CONTROL DIMENSION IS IN INCHES. DIMENSION IN BRACKET IS IN MILLIMETERS.
- 2) PACKAGE LENGTH DOES NOT INCLUDE MOLD FLASH, PROTRUSIONS OR GATE BURRS.
- 3) PACKAGE WIDTH DOES NOT INCLUDE INTERLEAD FLASH OR PROTRUSIONS.
- 4) LEAD COPLANARITY (BOTTOM OF LEADS AFTER FORMING) SHALL BE 0.004" INCHES MAX.
- 5) DRAWING CONFORMS TO JEDEC MS-012, VARIATION BA.
- 6) DRAWING IS NOT TO SCALE.