

## Synchronous Buck DC/DC Converter < A 3406

### Features

- Up to 95% Efficiency
- Current mode operation for excellent line and load transient response
- Low quiescent current: 230μA
- Low Switch on Resistance  $R_{DS(ON)}$ , Internal Switch: 0.35Ω
- Output voltage: 5.5V~0.6V
- Automatic PWM/PFM mode switching
- No Schottky diode required
- 1.4MHz fixed frequency switching
- Short-Circuit protection
- Shutdown quiescent current: < 1μA
- Low profile SOT-23-5 package (lead-free packaging is now available)

### Application

- Digital cameras and MP3
- Palmtop computers / PDAs
- Cellular phones
- Wireless handsets and DSL modems
- PC cards
- Portable media players

### Description

The <A3406 is high efficiency synchronous, PWM step-down DC/DC converters working under an input voltage range of 2.5V to 5.5V. This feature makes the <A3406 suitable for single Li-Ion battery-powered applications. 100% duty cycle capability extends battery life in portable devices, while the quiescent current is 200μA with no load, and drops to < 1μA in shutdown.

The internal synchronous switch is desired to increase efficiency without an external Schottky diode. The 1.4 MHz fixed switching frequency allows the using of tiny, low profile inductors and ceramic capacitors, which minimized overall solution footprint.

The <A3406 converters are available in the industry standard SOT-23-5 power packages (or upon request).

### Order Information

<A3406N - ①② :

Symbol	Description
①	Denotes Output voltage: 12:1.2V Output 15 : 1.5V Output; 18 : 1.8V Output; 33:3.3V Output FB : Adjustable Output
②	Denotes Package Types: MR: SOT-23-5

## Typical Applications

### FIXED OUTPUT VOLTAGE

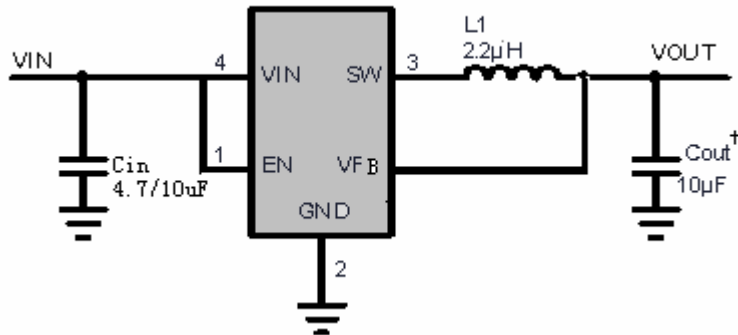

Model	VOUT (V)	VIN (V)	Mark
<A 3406N12	1.2	2.2~5.5	HX-KG
<A' 406N15	1.5	2.4~5.5	HX-FG
<A 3406N18	1.8	2.5~5.5	HX-UG
<A 3406N33	3.3	3.4~5.5	HX-NG

### ADJUSTABLE OUTPUT VOLTAGE

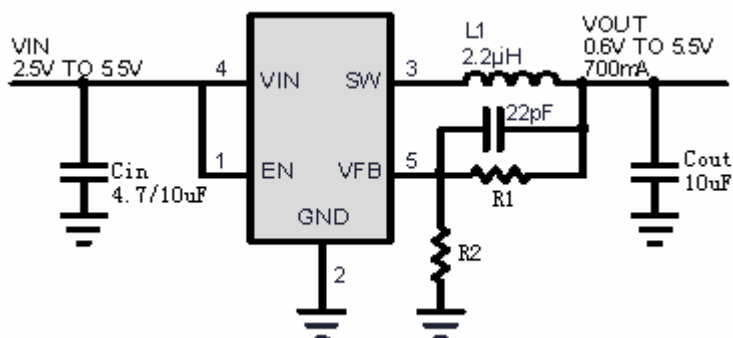

Model	VOUT (V)	Mark
<A 3406NFB	Adjustable Output Voltage	HX-VG

THE DEVICE RECOMMENDED

VOUT (V)	CAPACITOR SIZE/TYPE		RESISTOR SIZE/TYPE		INDUCTOR SIZE/TYPE ( $\mu$ H)
	CIN( $\mu$ F)	COUT( $\mu$ F)	R1(K $\Omega$ )	R2(K $\Omega$ )	
1.2	4.7/10(0805)	10(0805)	100 (0805)	100 (0805)	CKH4B28-2.2 $\mu$ H
1.5	4.7/10(0805)	10(0805)	1000(0805)	620(0805)	CKH4B28-2.2 $\mu$ H
1.8	4.7/10(0805)	10(0805)	200(0805)	100(0805)	CKH4B28-2.2 $\mu$ H
3.3	4.7/10(0805)	10(0805)	330(0805)	75(0805)	CKH4B28-2.2 $\mu$ H

Pin Assignment

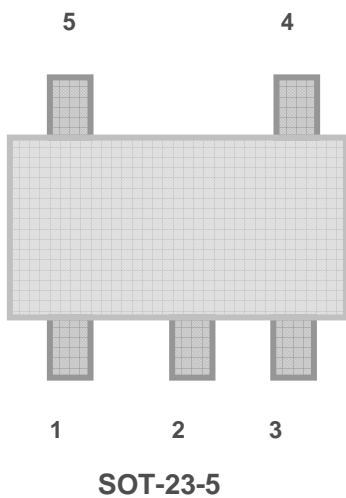

PIN NUMBER SOT-23- 5	PIN NAME	FUNCTION
1	EN	ON/OFF Control (High Enable)
2	GND	Ground
3	SW	Switch Output
4	V <sub>IN</sub>	Input
5	V <sub>FB</sub>	Output

Functional Diagram

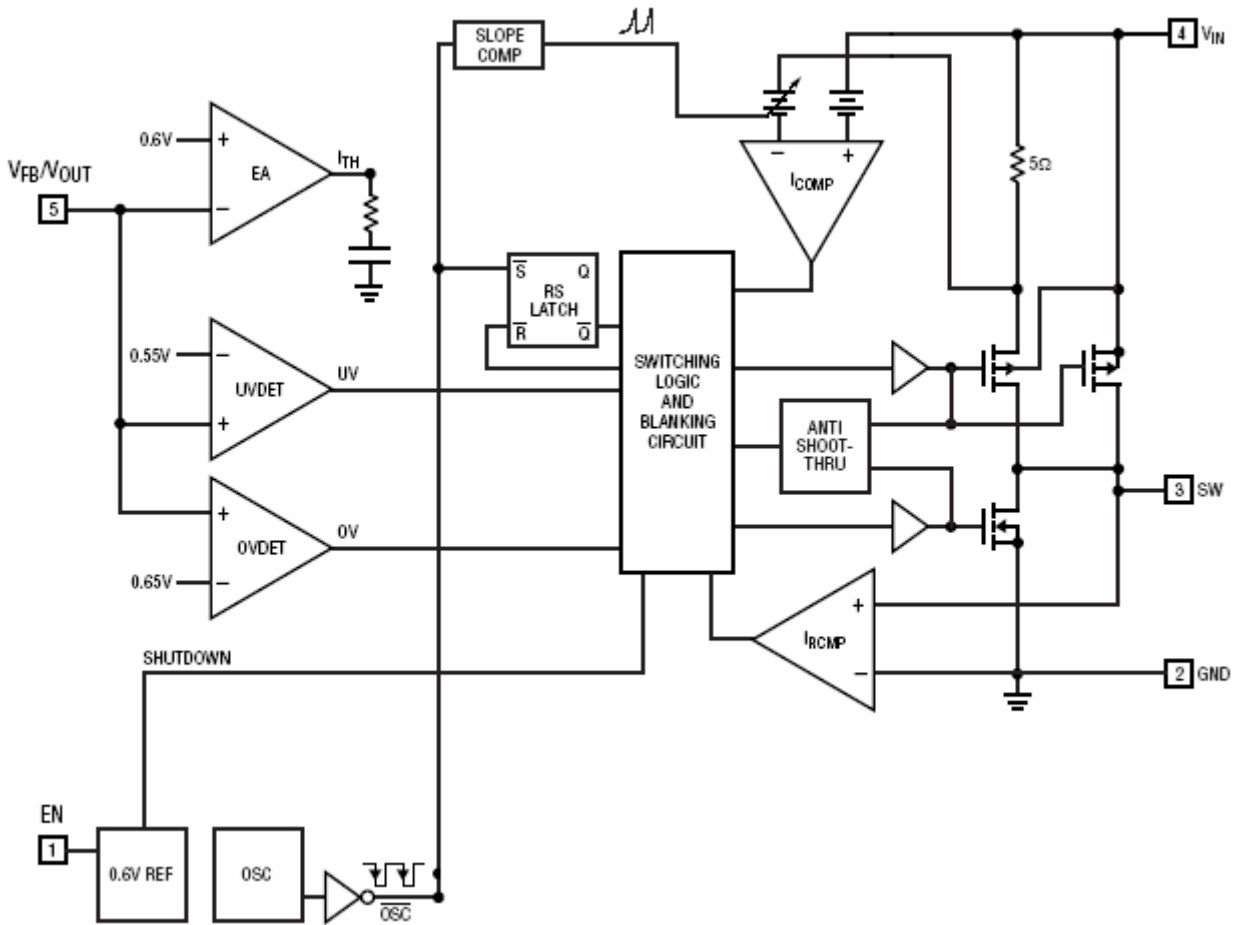

## Absolute Maximum Ratings

- Power Dissipation.....Internally limited
- $V_{IN}$  .....- 0.3 V ~ + 6 V
- $V_{ON/OFF}$  .....- 0.3 V ~ ( $V_{IN} + 0.3$ ) V
- $V_{SW}$  .....- 0.3 V ~ ( $V_{IN} + 0.3$ ) V
- $V_{FB}$ .....- 0.3 V ~ + 6 V
- $I_{SW}$  .....1.3A
- Operating Temperature Range .....- 40°C ~ + 85°C
- Lead Temperature (Soldering 10 sec.) .....+ 300°C
- Storage Temperature Range .....- 65°C ~ + 150°C
- Junction Temperature .....+ 125°C

## Electrical Characteristics

Operating Conditions:  $T_A=25^\circ\text{C}$ ,  $V_{IN}=3.6\text{V}$  unless otherwise specified.

SYMBOL	PARAMETER	CONDITIONS	MIN	TYP	MAX	UNITS
$V_{OUT}$	Output Voltage	$I_{OUT} = 100\text{mA}$ , $R1/R2=2$	1.75	1.80	1.85	V
$V_{IN}$	Input Voltage Range		2.5		5.5	V
$V_{FB}$	Regulated Voltage	$T_A = 25^\circ\text{C}$	0.5880	0.6	0.6120	V
$I_{FB}$	Feedback Current				$\pm 30$	nA
$\Delta V_{FB}$	$V_{REF}$	$V_{IN}=2.5\text{V}\sim 5.5\text{V}$		0.03	0.4	%/V
$F_{OSC}$	Oscillator Frequency	$V_{FB} = 0.6\text{V}$ or $V_{OUT} = 100\%$	1.1	1.4	1.7	MHz
$I_Q$	Quiescent Current	$V_{FB} = 0.5\text{V}$ or $V_{OUT} = 90\%$ , $I_{LOAD} = 0\text{A}$		200	300	$\mu\text{A}$
$I_S$	Shutdown Current	$V_{EN} = 0\text{V}$ , $V_{IN} = 4.2\text{V}$		0.1	1	$\mu\text{A}$
$I_{PK}$	Peak Inductor Current	$V_{IN} = 3\text{V}$ , $V_{FB} = 0.5\text{V}$ or $V_{OUT} = 90\%$ , Duty Cycle < 35%	0.75	0.9	1	A
$R_{PFET}$	$R_{DS(ON)}$ of P-Channel FET	$I_{SW} = 100\text{mA}$		0.4	0.5	$\Omega$
$R_{NFET}$	$R_{DS(ON)}$ of N-Channel FET	$I_{SW} = -100\text{mA}$		0.35	0.45	$\Omega$
$EFFI^*$	Efficiency	When connected to ext. components $V_{IN}=EN=3.6\text{V}$ , $I_{OUT}=100\text{mA}$		93		%
$\Delta V_{OUT}$	$V_{OUT}$ Line Regulation	$V_{IN}=2.5\text{V}\sim 5.5\text{V}$		0.03	0.3	%/V
$V_{LOADREG}$	$V_{OUT}$ Load Regulation			0.33		%

\*  $EFFI = [(\text{Output Voltage} \times \text{Output Current}) / (\text{Input Voltage} \times \text{Input Current})] \times 100\%$

## Typical Performance Characteristics

VOUT=1.8V

VOUT=2.5V

CONVERSION EFFICIENCY

CONVERSION EFFICIENCY

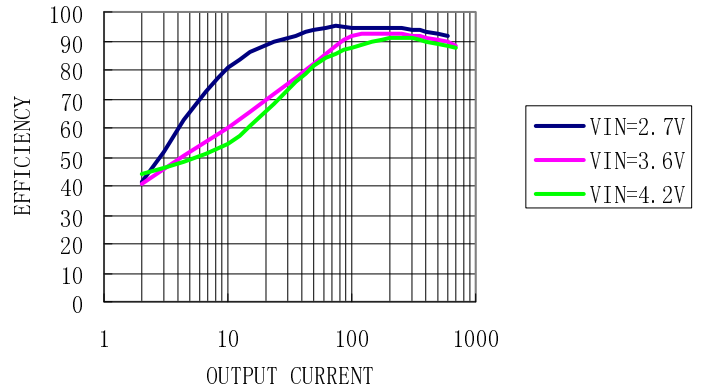
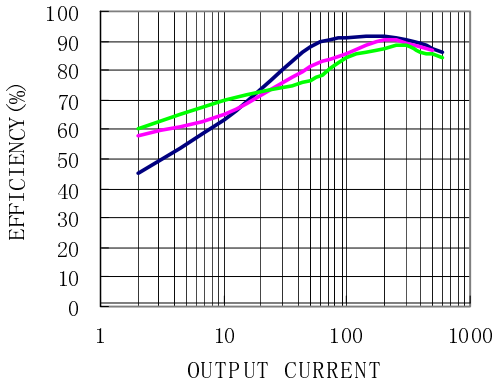

Output Noise  
 100mV/DIV  
 AC COUPLED

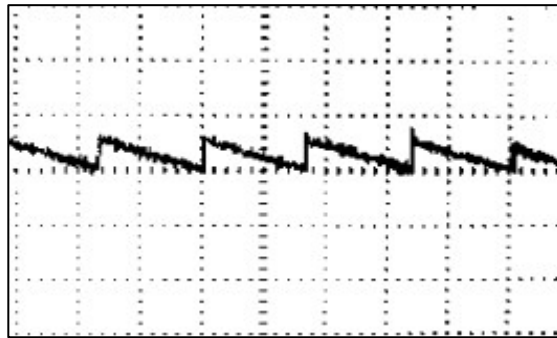

VIN=3.6V  
 VOUT=1.8V  
 ILOAD=0mA

2ms/DIV

Output Noise  
 10mV/DIV  
 AC COUPLED

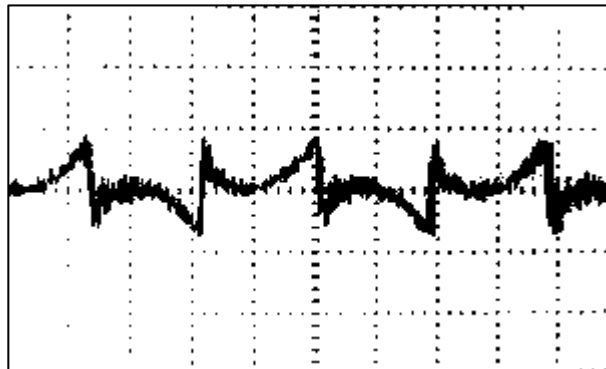

VIN=3.6V  
 VOUT=1.8V  
 ILOAD=200mA

200ns/DIV

## Typical Performance Characteristics

Start-up from shutdown

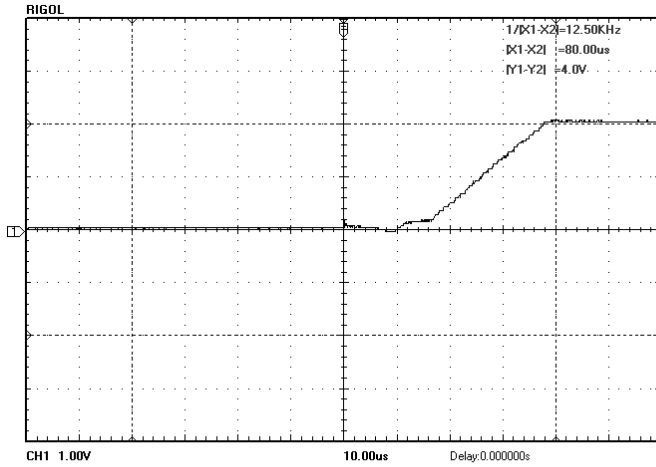

Quiescent Supply Current vs. Supply Voltage

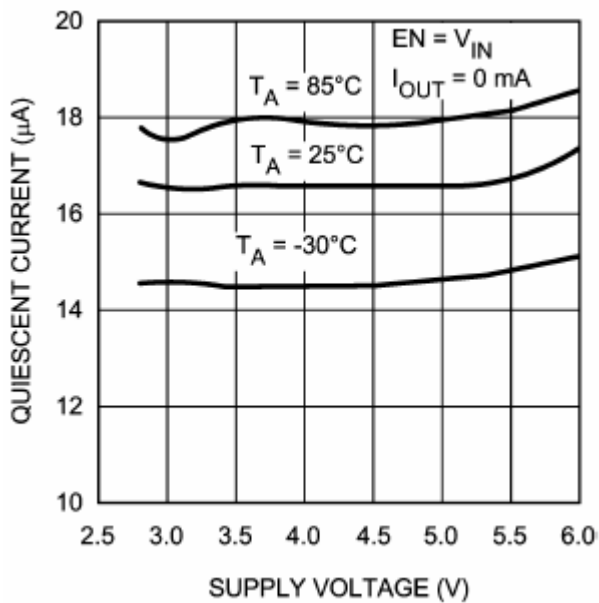

Feed back Bias Current vs. Temp

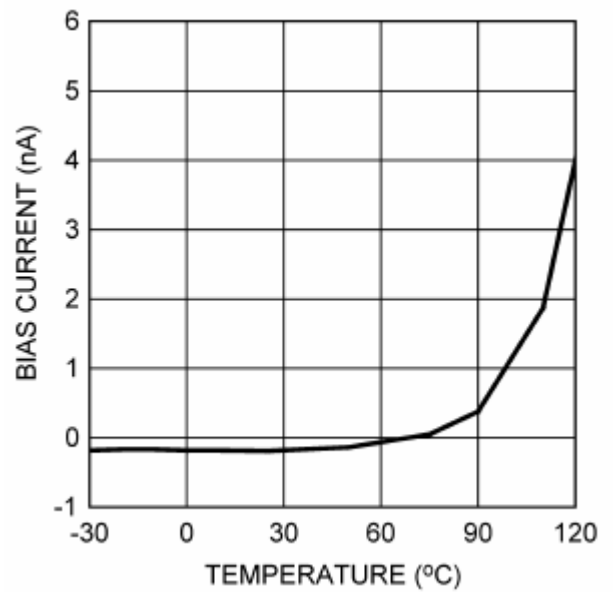

## Typical Performance Characteristics

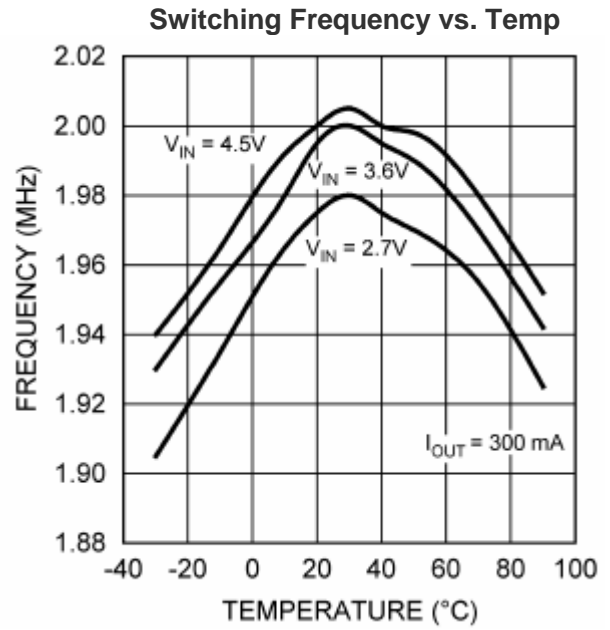
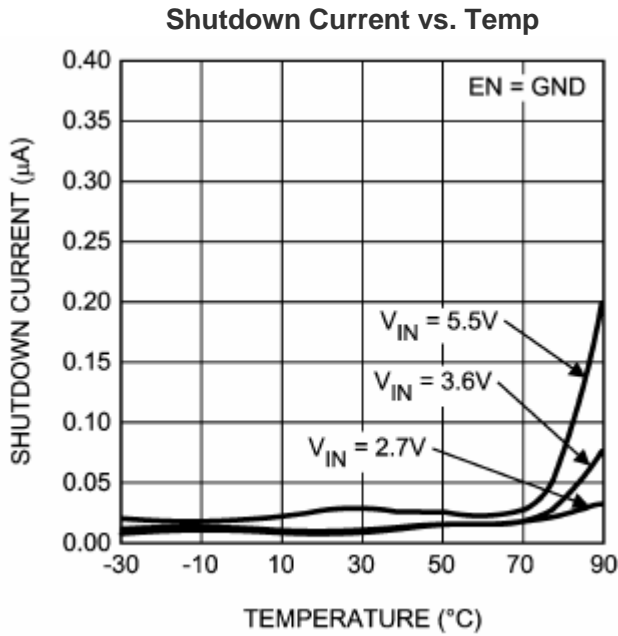

**Rds(on) vs. Temp**

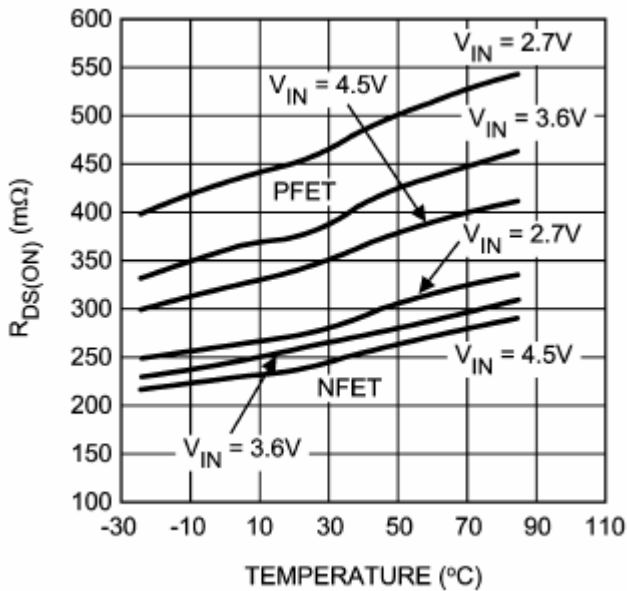

**Open/Closed Loop Current Limit vs. Temp**

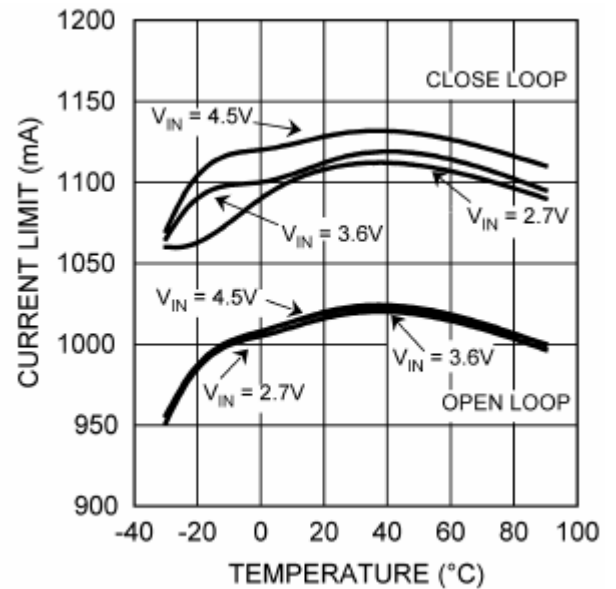



---

## Application Information

### PIN ASSIGNMENT

**EN (Pin 1):** En Control Input. Forcing this pin above 1.5V enables the part. Forcing this pin below 0.3V shutsdown the device. In shutdown, all functions are disabled drawing <math><1\mu\text{A}</math> supply current. Do not leave EN floating.

**GND (Pin 2):** Ground Pin.

**SW (Pin 3):** Switch Node Connection to Inductor. This pin connects to the drains of the internal main and synchronous power MOSFET switches.

**V<sub>IN</sub> (Pin 4):** Main Supply Pin. Must be closely decoupled to GND, Pin 2, with a 2.2 $\mu\text{F}$  or greater ceramic capacitor.

**V<sub>FB</sub> (Pin 5) (< A 3406NFB):** Feedback Pin. Receives the feedback voltage from an external resistive divider across the output. In the adjustable version, the output voltage is set by a resistive divider according to the following formula:  $V_{\text{OUT}} = 0.6\text{V} \cdot [1 + (R1/R2)]$ .

**V<sub>OUT</sub> (Pin 5) (< A 3406N12/< A 3406N15/< A 3406N18):** Output Voltage Feedback Pin. An internal resistive divider divides the output voltage down for comparison to the internal reference voltage.

## PCB LAYOUT GUIDELINES

When laying out the printed circuit board, the following checklist should be used to ensure proper operation of the <A3406. These items are also illustrated graphically in Figures 1 and 2. Check the following in your layout:

1. The power traces, consisting of the GND trace, the SW trace and the  $V_{IN}$  trace should be kept short, direct and wide.
2. Does the  $V_{FB}$  pin connect directly to the feedback resistors? The resistive divider R1/R2 must be connected between the (+) plate of  $C_{OUT}$  and ground.
3. Does the (+) plate of  $C_{IN}$  connect to  $V_{IN}$  as closely as possible? This capacitor provides the AC current to the internal power MOSFETs.
4. Keep the switching node, SW, away from the sensitive  $V_{FB}$  node.
5. Keep the (-) plates of  $C_{IN}$  and  $C_{OUT}$  as close as possible.

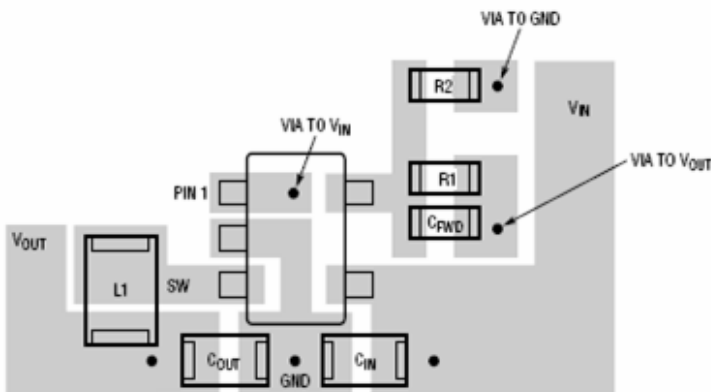

Figure 1. <A3406NFB Suggested Layout

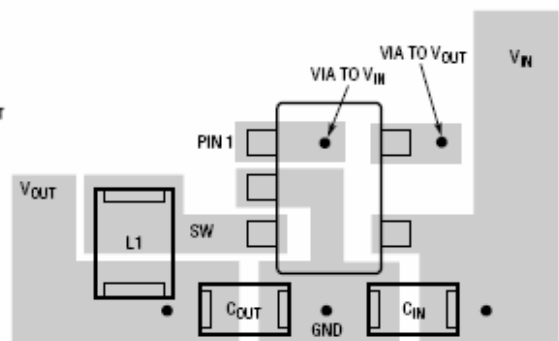

Figure 2.  
 <A3406N12/<A3406N15/<A3406N18  
 /<A3406N33 Suggested  
 Layout

## INDUCTOR SELECTION

For most applications, the value of the inductor will fall in the range of 1μH to 4.7μH. Its value is chosen based on the desired ripple current. Large value inductors lower ripple current and small value inductors result in higher ripple currents. Higher  $V_{IN}$  or  $V_{OUT}$  also increases the ripple current as shown in equation 1. A reasonable starting point for setting ripple current is  $\Delta I_L = 240\text{mA}$  (40% of 600mA).

$$\Delta I_L = \frac{1}{(f)(L)} V_{OUT} \left( 1 - \frac{V_{OUT}}{V_{IN}} \right)$$

The DC current rating of the inductor should be at least equal to the maximum load current plus half the ripple current to prevent core saturation. Thus, a 720mA rated inductor should be enough for

most applications (600mA + 120mA). For better efficiency, choose a low DC-resistance inductor. Different core materials and shapes will change the size/current and price/current relationship of an inductor. Toroid or shielded pot cores in ferrite or permalloy materials are small and don't radiate much energy, but generally cost more than powdered iron core inductors with similar electrical characteristics. The choice of which style inductor to use often depends more on the price vs size requirements and any radiated field/EMI requirements than on what the <A3406 requires to operate. Table 1 shows some typical surface mount inductors that work well in <A3406 applications.

Table 1. Recommended Inductors

Part	L (μH)	Max DCR (mΩ)	Max DC Current (A)	Size W × L × H (mm <sup>3</sup> )	Vendor
CDRH3D16	2.2	75	1.20	3.8 × 3.8 × 1.8	Sumida
CDH3B16	2.2	70	1.20	4.0 × 4.0 × 1.8	Ceaiya

## OUTPUT AND INPUT CAPACITOR SELECTION

In continuous mode, the source current of the top MOSFET is a square wave of duty cycle  $V_{OUT}/V_{IN}$ . To prevent large voltage transients, a low ESR input capacitor sized for the maximum RMS current must be used. The maximum RMS capacitor current is given by:

$$C_{IN} \text{ required } I_{RMS} \cong I_{OMAX} \frac{[V_{OUT}(V_{IN} - V_{OUT})]^{1/2}}{V_{IN}}$$

This formula has a maximum at  $V_{IN} = 2V_{OUT}$ , where  $I_{RMS} = I_{OUT}/2$ . This simple worst-case condition is commonly used for design because even significant deviations do not offer much relief. Note that the capacitor manufacturer's ripple current ratings are often based on 2000 hours of life. This makes it advisable to further derate the capacitor, or choose a capacitor rated at a higher temperature than required. Always consult the manufacturer if there is any question.

The selection of  $C_{OUT}$  is driven by the required effective series resistance (ESR).

Typically, once the ESR requirement for  $C_{OUT}$  has been met, the RMS current rating generally far exceeds the  $I_{RIPPLE(P-P)}$  requirement. The output ripple  $\Delta V_{OUT}$  is determined by:

$$\Delta V_{OUT} \cong \Delta I_L \left( ESR + \frac{1}{8fC_{OUT}} \right)$$

where  $f$  = operating frequency,  $C_{OUT}$  = output capacitance and  $\Delta I_L$  = ripple current in the inductor. For a fixed output voltage, the output ripple is highest at maximum input voltage since  $\Delta I_L$  increases with input voltage.

Aluminum electrolytic and dry tantalum capacitors are both available in surface mount configurations. In the case of tantalum, it is critical that the capacitors are surge tested for use in switching power supplies. An excellent choice is the AVX TPS series of surface mount tantalum. These are specially constructed and tested for low ESR so they give the lowest ESR for a given volume. Other capacitor types include Sanyo POSCAP, Kemet T510 and T495 series, and Sprague 593D and 595D series. Consult the manufacturer for other specific recommendations.

## Packaging Information

### SOT-23-5 Package Outline Dimension

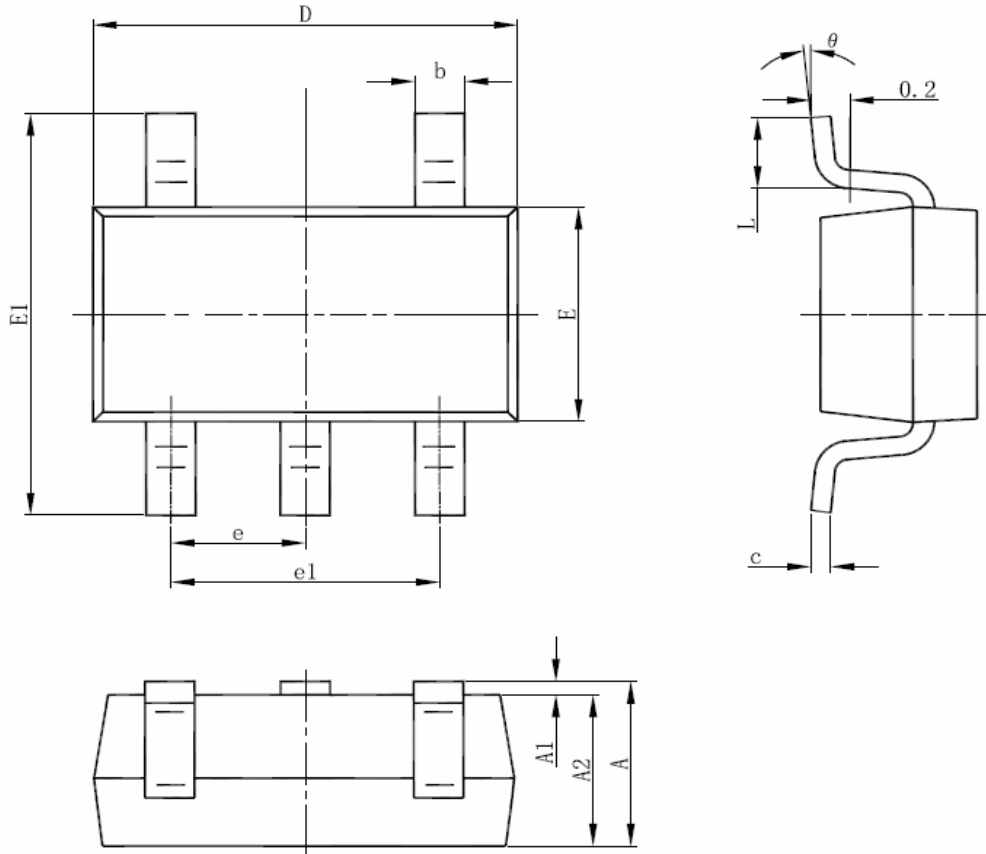

Symbol	Dimensions In Millimeters		Dimensions In Inches	
	Min	Max	Min	Max
A	1.050	1.250	0.041	0.049
A1	0.000	0.100	0.000	0.004
A2	1.050	1.150	0.041	0.045
b	0.300	0.500	0.012	0.020
c	0.100	0.200	0.004	0.008
D	2.820	3.020	0.111	0.119
E	1.500	1.700	0.059	0.067
E1	2.650	2.950	0.104	0.116
e	0.950(BSC)		0.037(BSC)	
e1	1.800	2.000	0.071	0.079
L	0.300	0.600	0.012	0.024
	0°	8°	0°	8°