

## Features

- Wide 8V to 40V input voltage range.
- Fixed 5V output voltage.
- Maximum 3.2A output current.
- Fixed 150KHz switching frequency.
- Internal optimize power MOSFET.
- High efficiency up to 92%.
- Built in output short shutdown function.
- Excellent line and load regulation.
- Built in thermal shutdown function.
- Built in current limit function.
- Available in TO252-5L package.

## Applications

- Car Charger
- Battery Charger
- USB Power Supply

## General Description

The HM3513 is a 150KHz fixed frequency PWM buck (step-down) DC/DC converter, capable of driving a 3.2A load with high efficiency, low ripple and excellent line and load regulation. Requiring a minimum number of external components, the regulator is simple to use and include internal frequency compensation and a fixed-frequency oscillator.

The HM3513 built in output short protection function. When short protection function happens, the chip will be shutdown. An internal compensation block is built in to minimize external component count.

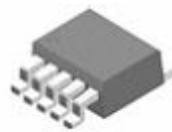

Figure1. Package Type of HM3513

## Pin Configurations

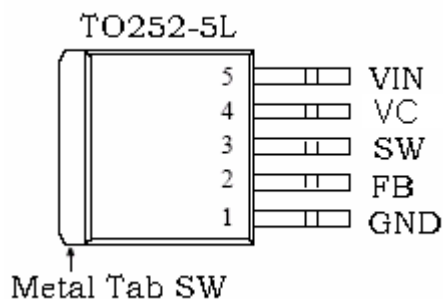

Figure2. Pin Configuration of HM3513 (Top View)

Table 1 Pin Description

Pin Number	Pin Name	Description
1	GND	Ground Pin. Care must be taken in layout. This pin should be placed outside of the Schottky Diode to output capacitor ground path to prevent switching current spikes from inducing voltage noise into HM3513.
2	FB	Feedback Pin (FB). The feedback threshold voltage is 5V.
3	SW	Power Switch Output Pin (SW). SW is the switch node that supplies power to the output.
4	VC	Internal Voltage Regulator Bypass Capacity. In typical system application, The VC pin connect a 1uF capacity to VIN.
5	VIN	Supply Voltage Input Pin. HM3513 operates from 8V to 40V DC voltage. Bypass Vin to GND with a suitably large capacitor to eliminate noise on the input.

**Function Block**

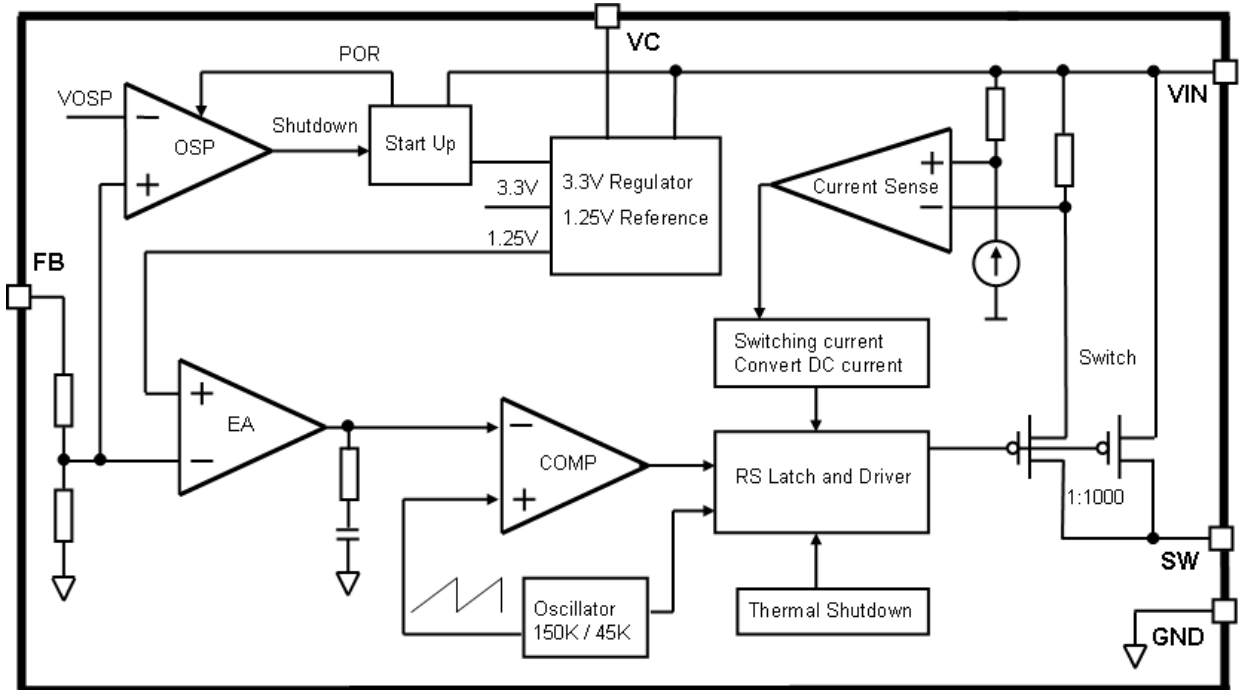

Figure3. Function Block Diagram of HM3513

**Typical Application Circuit**

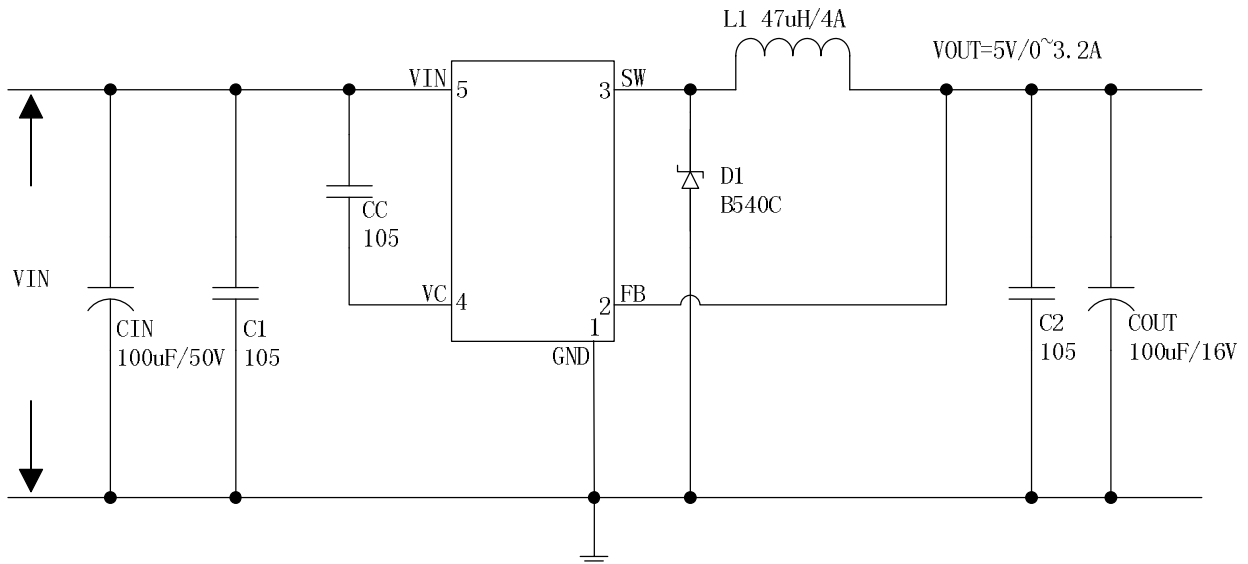

Figure4. HM3513 Typical Application Circuit (VIN=8V~40V, VOUT=5V/3.2A)

## Ordering Information

Package	Temperature Range	Part Number	Marking ID	Packing Type
		Lead Free	Lead Free	
		HM3513	HM3513	

## Absolute Maximum Ratings (Note1)

Parameter	Symbol	Value	Unit
Input Voltage	$V_{in}$	-0.3 to 45	V
Feedback Pin Voltage	$V_{FB}$	-0.3 to $V_{in}$	V
Output Switch Pin Voltage	$V_{Output}$	-0.3 to $V_{in}$	V
Power Dissipation	$P_D$	Internally limited	mW
Thermal Resistance (TO252-5L) (Junction to Ambient, No Heatsink, Free Air)	$R_{JA}$	50	°C/W
Operating Junction Temperature	$T_J$	-40 to 125	°C
Storage Temperature	$T_{STG}$	-65 to 150	°C
Lead Temperature (Soldering, 10 sec)	$T_{LEAD}$	260	°C
ESD (HBM)		>2000	V

**Note1:** Stresses greater than those listed under Maximum Ratings may cause permanent damage to the device. This is a stress rating only and functional operation of the device at these or any other conditions above those indicated in the operation is not implied. Exposure to absolute maximum rating conditions for extended periods may affect reliability.

### HM3513 Electrical Characteristics

$T_a = 25^\circ\text{C}$ ; unless otherwise specified.

Symbol	Parameter	Test Condition	Min.	Typ.	Max.	Unit
<i>System parameters test circuit figure4</i>						
VFB	Feedback Voltage	$V_{in} = 8\text{V to } 40\text{V}, V_{out}=5\text{V}$ $I_{load}=0.5\text{A to } 3.2\text{A}$	4.9	5	5.1	V
Efficiency	$\eta$	$V_{in}=12\text{V}, V_{out}=5\text{V}$ $I_{out}=3.2\text{A}$	-	87	-	%

### Electrical Characteristics (DC Parameters)

$V_{in} = 12\text{V}$ ,  $GND=0\text{V}$ ,  $V_{in}$  &  $GND$  parallel connect a  $100\mu\text{F}/50\text{V}$  capacitor;  $I_{out}=500\text{mA}$ ,  $T_a = 25^\circ\text{C}$ ; the others floating unless otherwise specified.

Parameters	Symbol	Test Condition	Min.	Typ.	Max.	Unit
Input operation voltage	$V_{in}$		8		40	V
Quiescent Supply Current	$I_q$	$V_{FB} = V_{in}$		4.7	10	mA
Output Short Supply Current	$I_{osp}$				5	mA
Oscillator Frequency	$F_{osc}$		127	150	173	KHz
Switch Current Limit	$I_L$	$V_{FB} = 0$		3.5		A
Output Power PMOS	$R_{dson}$	$V_{FB}=0\text{V}, V_{in}=12\text{V},$ $I_{SW}=3.2\text{A}$		70	90	mohm

**Typical System Application (VOUT=5V/3.2A)**

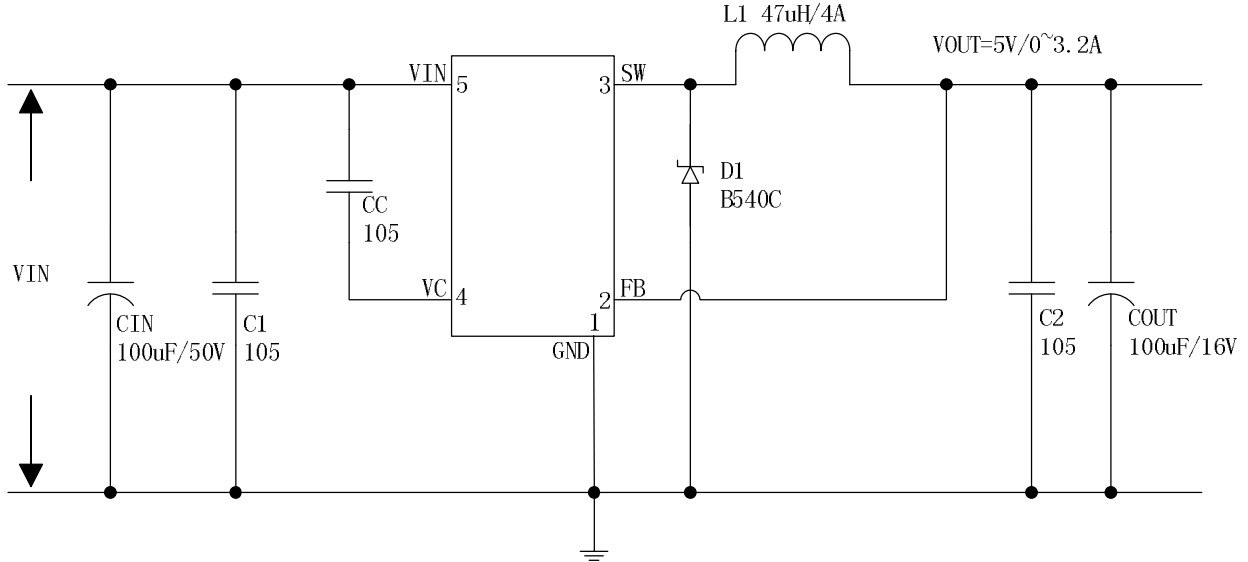

Figure5. HM3513 System Parameters Test Circuit (VIN=8V~40V, VOUT=5V/3.2A)

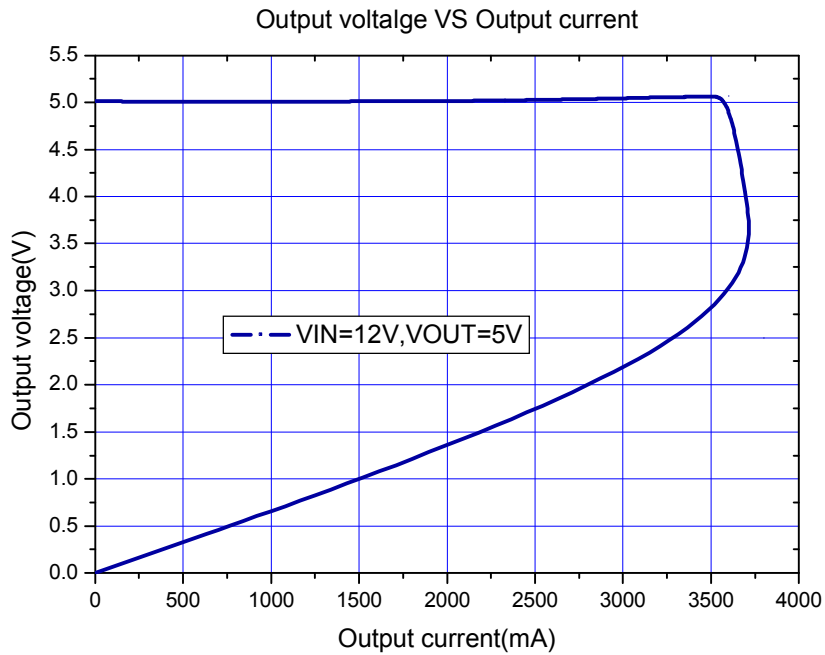

Figure6. HM3513 System Output Constant Current Curve

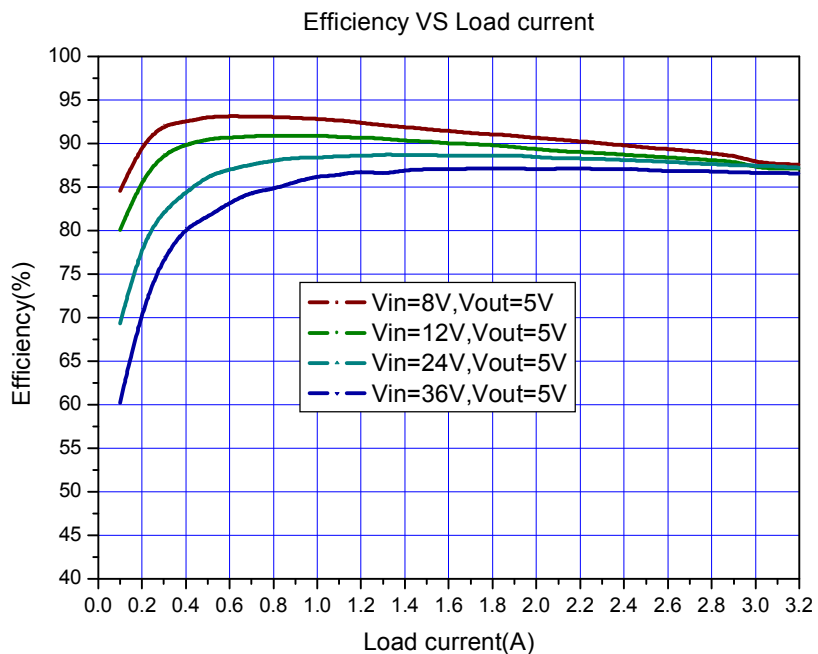

Figure7. HM3513 System Efficiency Curve

### Output short shutdown

The output short shutdown function is built in HM3513. The short protection circuit monitors the output voltage, whenever FB pin voltage is below 1.5V, the short circuit protection circuit is triggered, the converter will be shutdown, input current less than 5mA.

When the short fault is removed, if output load is floating, then converter will restart up, the output voltage will return to normal; if output load isn't floating, then converter must be power reset , the output voltage will comeback.

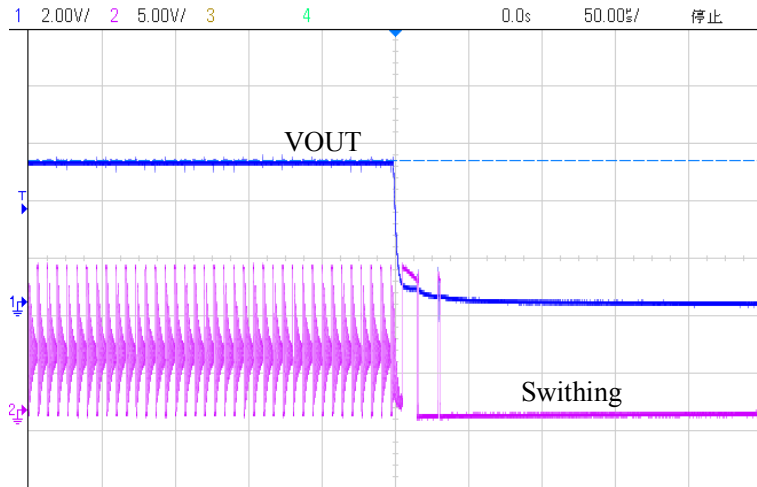

Figure8. The converter will be shutdown when output short happen.

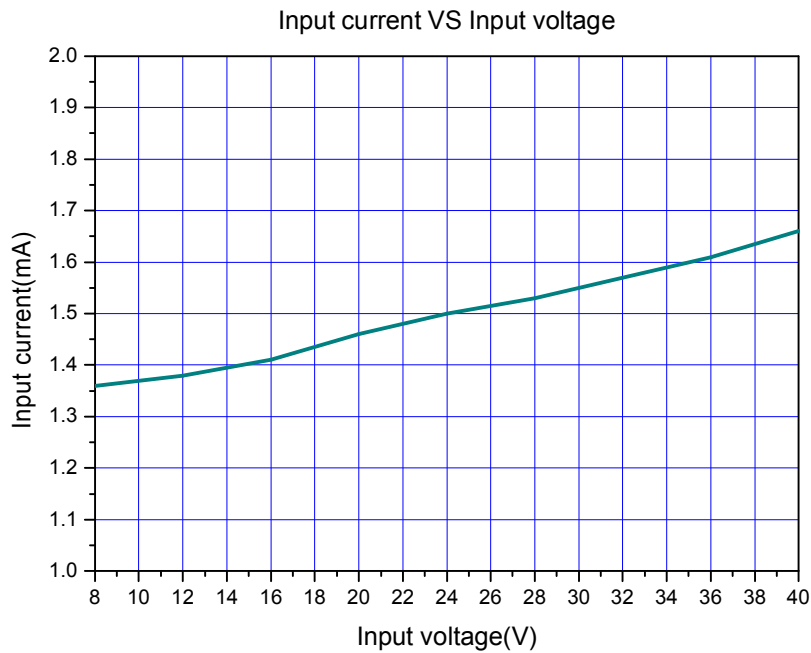
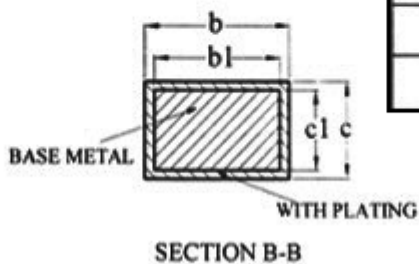
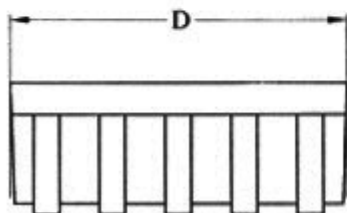
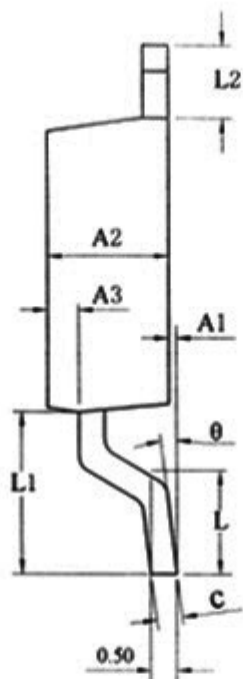
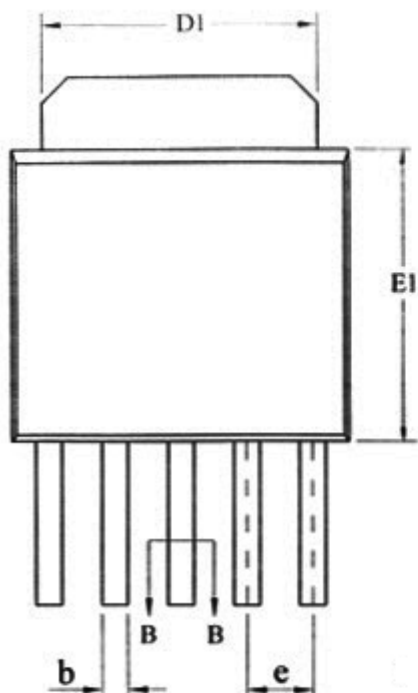

Figure9. The input current curve when output short happen.



### Package Information

TO252-5L



SYMBOL	MILLIMETER		
	MIN	NOM	MAX
A1	0.05	0.15	0.25
A2	2.10	2.30	2.50
A3	0.50	0.60	0.70
b	0.46	—	0.60
bl	0.45	0.50	0.55
c	0.49	—	0.56
c1	0.48	0.50	0.52
D	6.30	6.50	6.70
D1	5.30REF		
E1	5.30	5.50	5.70
e	1.27BSC		
L	1.40	1.50	1.60
L1	3.00	3.10	3.30
L2	1.40BSC		
θ	0	—	8°