

## General Description

The HM5188 is a synchronous rectifier, fixed switching frequency (1.2MHz typical), and current-mode step-up regulator. The device allows use of small inductors and output capacitors for USB devices. The current-mode control scheme provides fast transient response and good output voltage accuracy.

At light loads, the HM5188 will automatically enter in Pulse Frequency Modulation (PFM) operation to reduce the dominant switching losses. During PFM operation, the IC consumes very low quiescent current and maintains high efficiency over the complete load range. The HM5188 also includes current-limit and overtemperature shutdown to prevent damage in the event of an output overload.

The HM5188 is available in ESOP 8 packages.

## Features

- 92% Efficiency Synchronous Boost Converter With 1000-mA Output Current From 1.8V Input
- Stable with Low ESR Output Capacitors
- Fixed 1.2MHz Oscillator Frequency
- Low EMI Converter (Integrated Anti-Ringing Function)
- Low Battery Output
- Integrated Power Save Mode Operation to Improve Light Load Efficiency
- On load startup
- Automatic restart after protection
- Load Disconnected During Shutdown
- Output Current-Limit Protection
- Over Temperature Protection
- Under Voltage Protection
- Enable/Shutdown Function
- Available in ESOP-8 Packages
- Lead Free and Green Devices Available (RoHS Compliant)

## Applications

- Power Bank
- Tablet
- Portable Equipment

## Pin Configurations

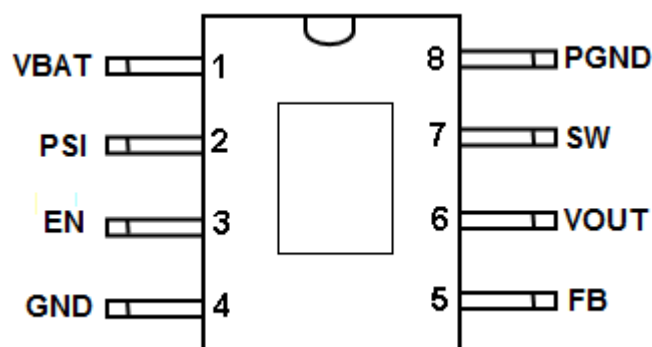

## Pin Description

NO.	NAME	FUNCTION
1	VBAT	Converter Supply Voltage.
2	PSI	Power Saving Input. Force $V_{PSI}$ exceed 1V enter PFM. Left $V_{PSI}$ below 0.4V enter PWM mode
3	EN	Device Enable Control Input. Force $V_{EN}$ exceed 1V enable the device. Left $V_{EN}$ below 0.4V to shutdown.
4	GND	Signal Ground. Connect this pin to PGND.
5	FB	Converter Feedback Input.
6	VOUT	Converter Output and IC Supply Voltage
7	SW	Converter Switch Pin. Connect inductor here.
8	PGND	Power Ground. Connect these pins to GND.

## Ordering Information

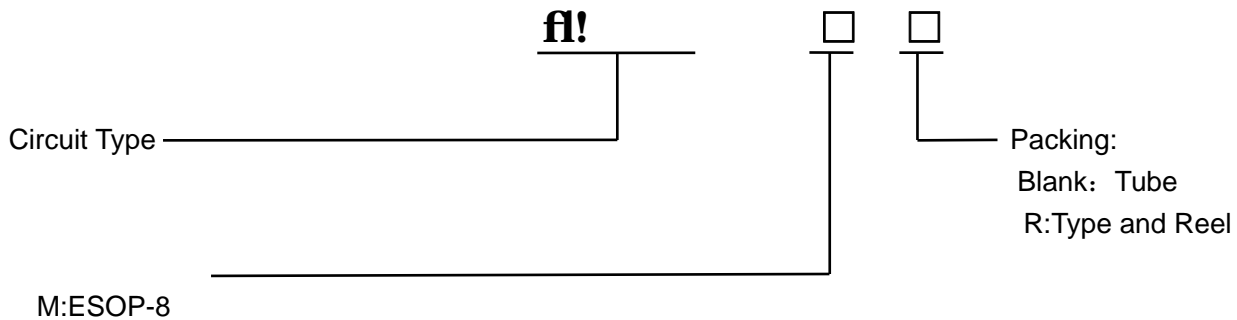

Functional Block Diagram

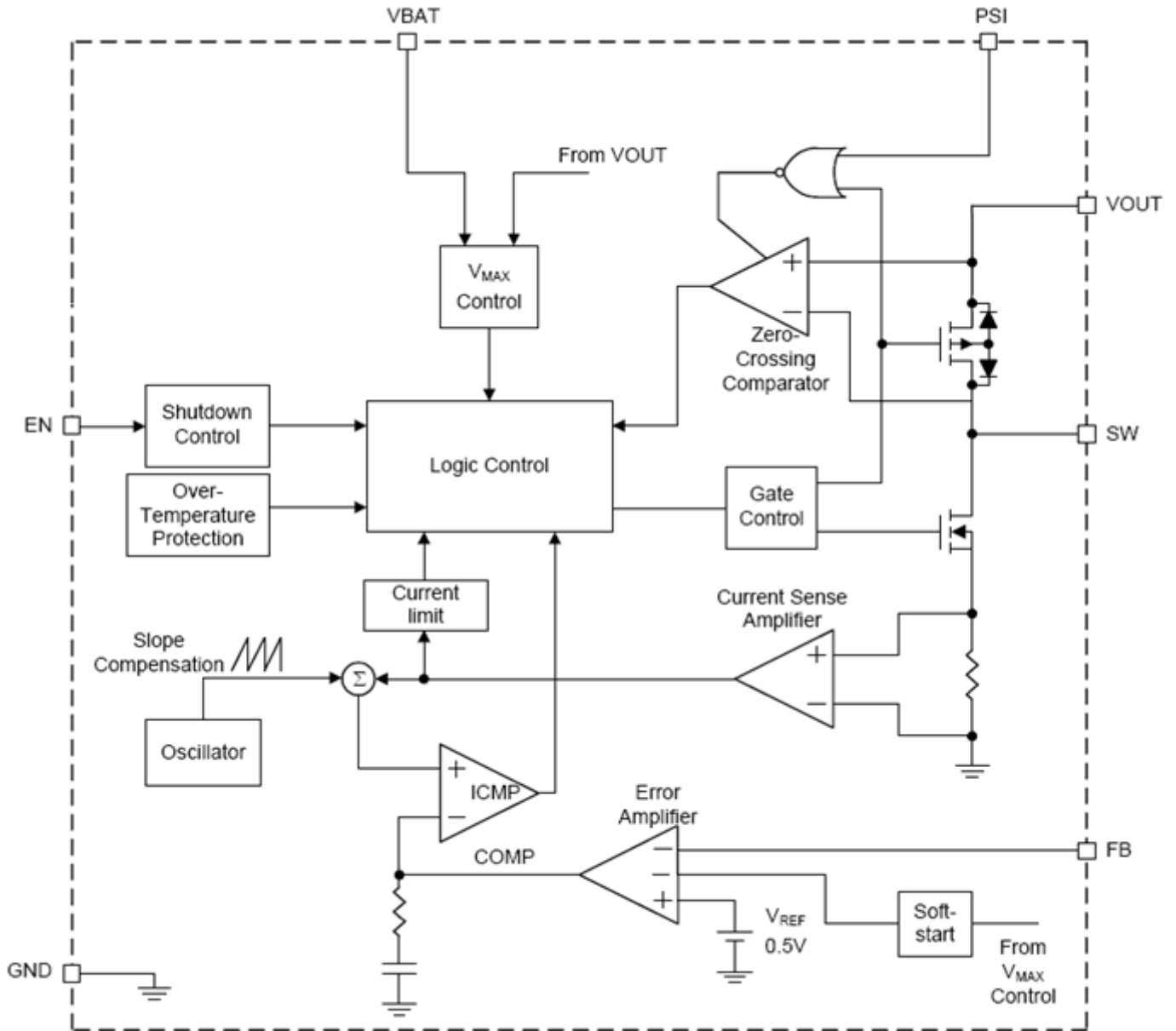

## Absolute Maximum Ratings

Symbol	Parameter	Rating	Unit
V <sub>OUT</sub>	Output and IC Supply Voltage (V <sub>OUT</sub> to GND)	-0.3 ~ 7	V
V <sub>BAT</sub>	Converter Supply Voltage (V <sub>BAT</sub> to GND)	-0.3 ~ 7	V
V <sub>SW</sub>	SW to GND Voltage	>30ns	-0.3 ~ 7
		<30ns	-0.3 ~ 9
	EN and FB to GND Voltage	-0.3 ~ 7	V
	PGND to GND	-0.3 ~ +0.3	V
T <sub>J</sub>	Maximum Junction Temperature	150	°C
T <sub>STG</sub>	Storage Temperature	-65 ~ 150	°C
T <sub>SDR</sub>	Maximum Lead Soldering Temperature (10 Seconds)	260	°C

Note1: Stresses beyond those listed under "absolute maximum ratings" may cause permanent damage to the device. These are stress ratings only and functional operation of the device at these or any other conditions beyond those indicated under "recommended operating conditions" is not implied. Exposure to absolute maximum rating conditions for extended periods may affect device reliability.

## Thermal Characteristics

Symbol	Parameter	Typical Value	Unit
θ <sub>JA</sub>	Junction-to-Ambient Resistance in free air (Note 2)	50	°C/W
θ <sub>JC</sub>	Junction-to-Case Resistance	20	°C/W

Note 2 : θ<sub>JA</sub> is measured with the component mounted on a high effective thermal conductivity test board in free air.

## Recommended Operating Conditions (Note 3)

Symbol	Parameter	Rating	Unit
V <sub>OUT</sub>	Output and IC Supply Voltage (V <sub>OUT</sub> to GND)	2.7 ~ 5.5	V
V <sub>BAT</sub>	Converter Supply Voltage (V <sub>BAT</sub> to GND)	1.8 ~ V <sub>OUT</sub>	V
V <sub>SW</sub>	SW to GND Voltage	>30ns	-0.3 ~ V <sub>OUT</sub> +0.3
		<30ns	-3 ~ V <sub>OUT</sub> +3
	LBI, SYNC, EN, LBO and FB to GND Voltage	0 ~ V <sub>OUT</sub>	V
T <sub>J</sub>	Junction Temperature	-40 ~ 125	°C
T <sub>A</sub>	Ambient Temperature	-40 ~ 85	°C

Note 3 : Refer to the typical application circuit

## Electrical Characteristics

Unless otherwise specified, these specifications apply over  $V_{BAT}=3.3V$ ,  $V_{OUT}=5V$  and  $T_A=25\text{ }^{\circ}C$ .

Symbol	Parameter	Test Conditions	Min	Typ	Max	Unit
$V_{BAT}$	Converter Supply Voltage Range		1.8	-	5.5	V
$V_{OUT}$	Converter Output and IC Supply Voltage		3.0	-	5.5	V
$I_{DD1}$	No Switching Quiescent Current	Measured from $V_{OUT}$ , $V_{FB}=0.6V$ , $V_{OUT}=3.3V$	-	40	60	$\mu A$
$I_{VBAT}$	$V_{BAT}$ Quiescent Current	Measured from $V_{BAT}$ , $V_{BAT}=3.3V$ , $EN=H$	-	0.5	1	$\mu A$
$I_{VBAT-SD}$	$V_{BAT}$ Quiescent Current	$V_{EN}=GND$ , $V_{BAT}=3.3V$ (Isolate $V_{BAT}$ & $V_{OUT}$ )	-	0.1	1	$\mu A$
$V_{UVLO}$	$V_{BAT}$ Under Voltage Lockout Threshold		1.6	1.7	1.8	V
$V_{REF}$	Regulated Feedback Voltage		490	500	510	mV
$I_{FB}$	FB Input Leakage Current		-100	-	100	nA
	Over Temperature Protection Hysteresis(note 4)	$T_J$ Falling	-	30	-	$^{\circ}C$
$F_{OSC}$	Switching Frequency	$FB=GND$	900	1200	1500	MHz
$R_{N-FET}$	N-FET Switch On Resistance	$V_{OUT}=5V$	-	55	-	$m\Omega$
$R_{P-FET}$	P-FET Switch On Resistance	$V_{OUT}=5V$	-	55	-	$m\Omega$
	N-FET Current Limit	$V_{OUT}=5V$	6	-	-	A
	Dead-time (note 4)	$V_{OUT}=3.3V-5V$	-	10	-	ns
$D_{MAX}$	SW Maximum Duty Cycle		85	95	-	%
	PFM Current Limit		-	700	-	mA
EN	EN Input Low Threshold		-	-	0.4	V
	EN Input High Threshold		1	-	-	V
	Internal Pull Low		-	500	-	$k\Omega$
PSI	PSI Input Low Threshold		-	-	0.4	V
	PSI Input High Threshold		1	-	-	V
$I_{EN}$	EN Input Leakage Current	$V_{EN}=1.5V$	-	3	5	$\mu A$
$I_{PSI}$	PSI Input Leakage Current	$V_{PSI}=1.5V$	-	0.4	1	$\mu A$
$V_{ZC}$	P-FET Zero Current Detect		-	+100	-	mA
	$V_{FB}$ Under Voltage Protection		70	75	80	$\%V_{REF}$
	UVP Debounce	(Option)	-	2	-	$\mu s$
$T_{OTP}$	Over Temperature Protection (note 4)	$T_J$ Rising	-	150	-	$^{\circ}C$
	Over Temperature Protection Hysteresis(note 4)	$T_J$ Falling	-	30	-	$^{\circ}C$

Note 4: Guaranteed by design, not production tested.

Typical Operating Characteristics

MAXIMUM OUTPUT CURRENT  
 vs  
 INPUT VOLTAGE

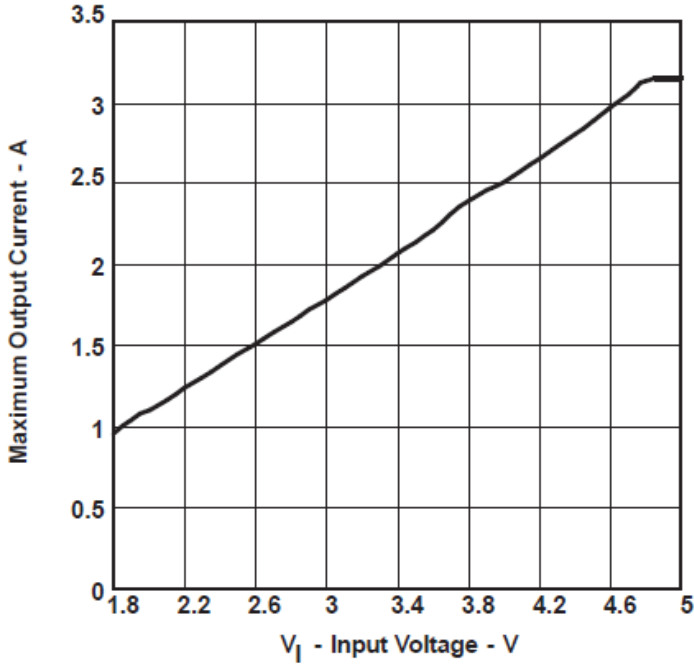

EFFICIENCY  
 vs  
 OUTPUT CURRENT

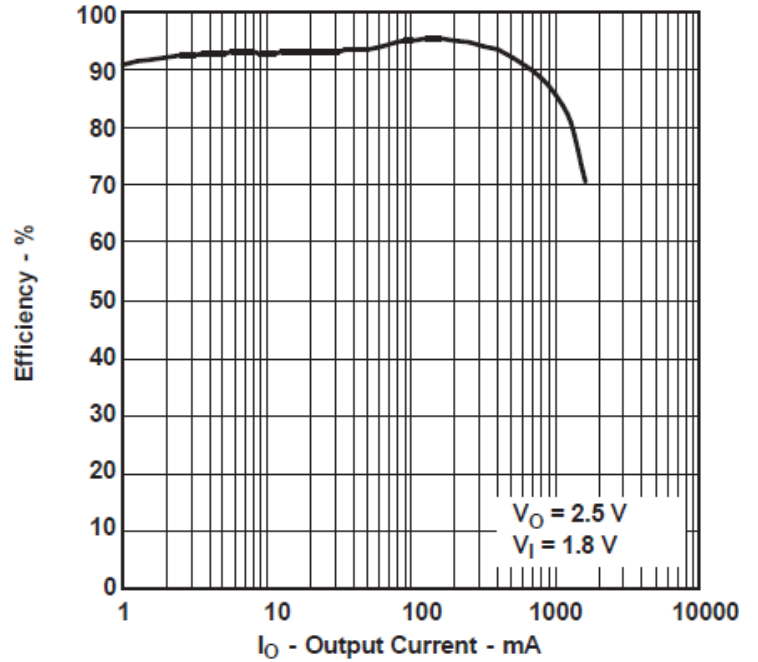

EFFICIENCY  
 vs  
 OUTPUT CURRENT

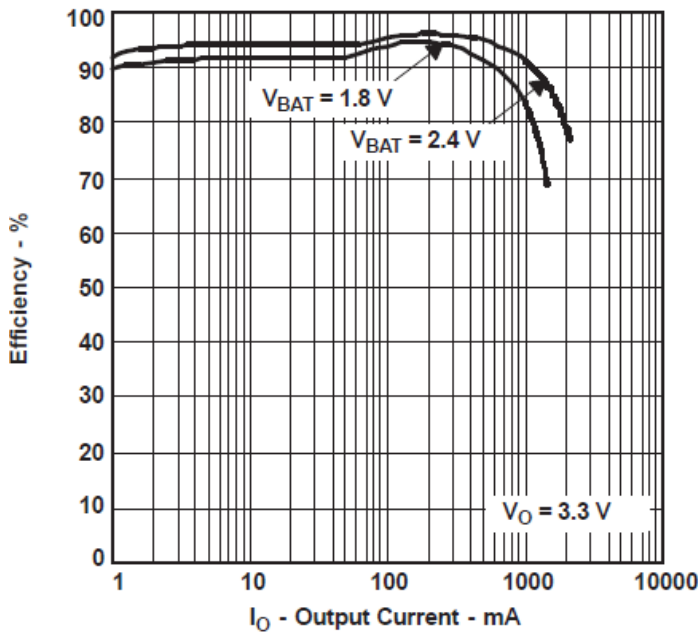

EFFICIENCY  
 vs  
 OUTPUT CURRENT

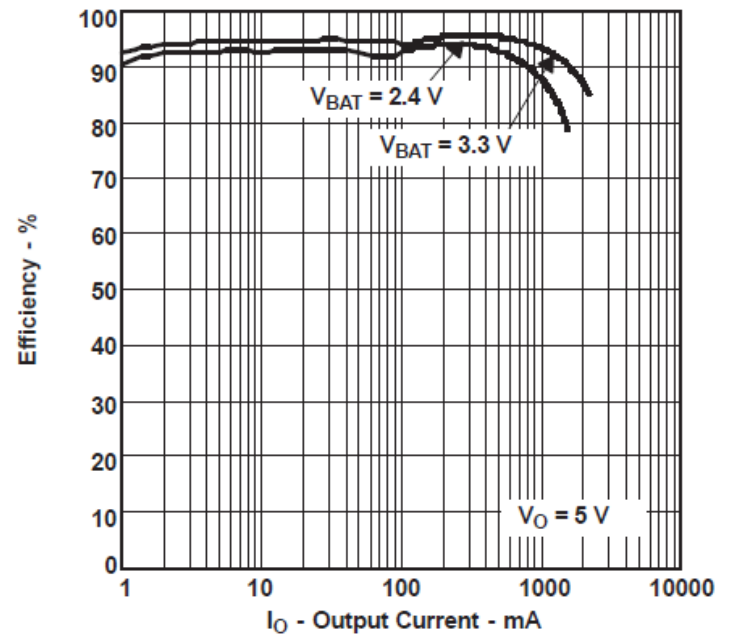

Typical Operating Characteristics(Cont.)

NO-LOAD SUPPLY CURRENT INTO VBAT  
 vs  
 INPUT VOLTAGE

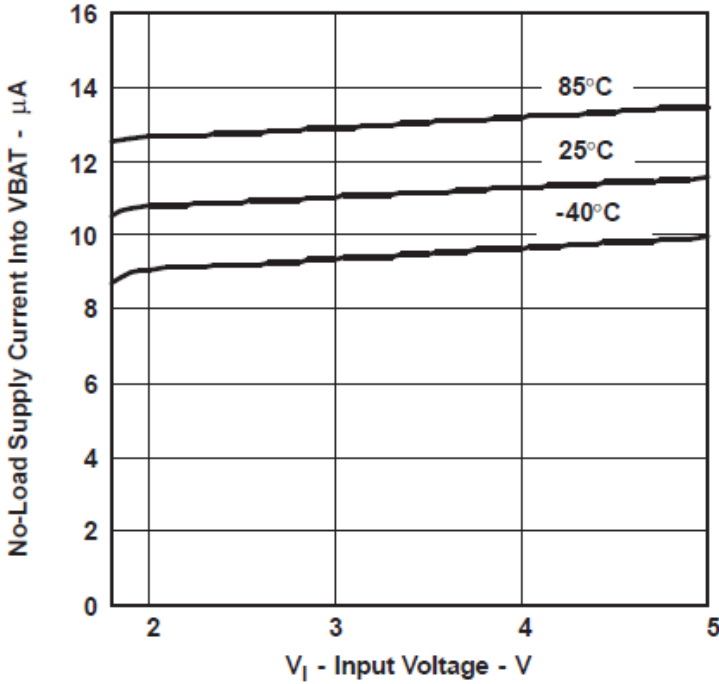

OUTPUT VOLTAGE  
 vs  
 OUTPUT CURRENT

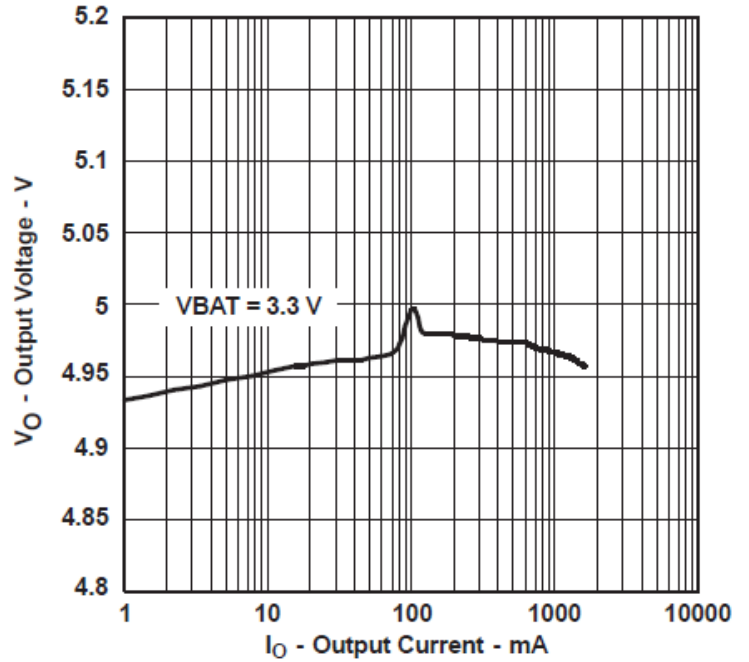

EFFICIENCY  
 vs  
 INPUT VOLTAGE

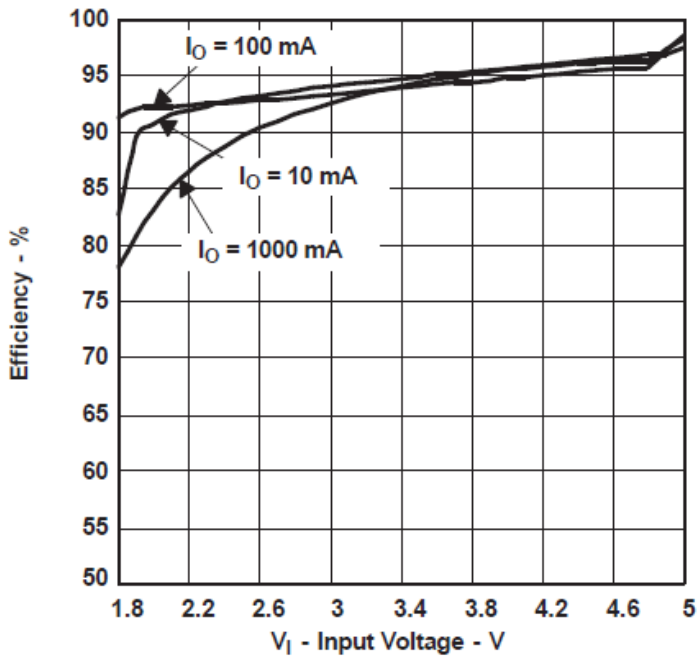

MINIMUM LOAD RESISTANCE AT START-UP  
 vs  
 INPUT VOLTAGE

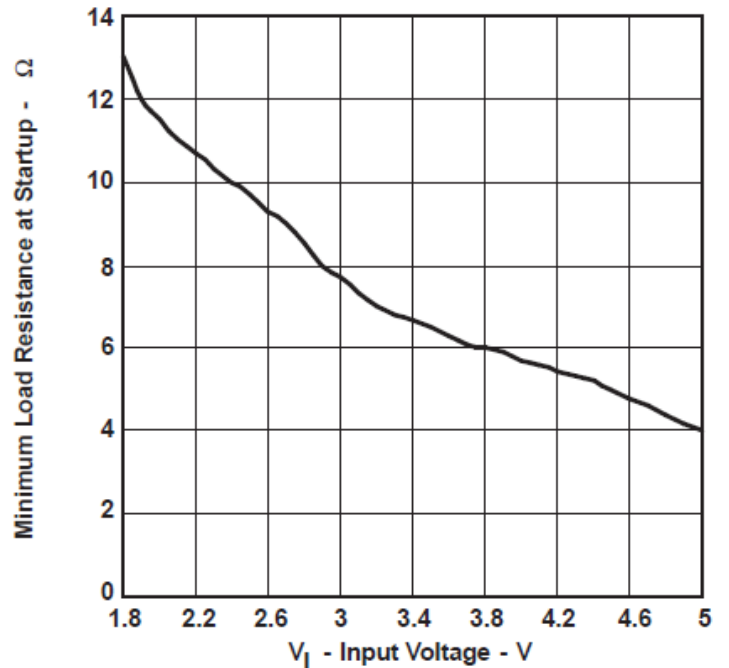

Typical Operating Characteristics(Cont.)

OUTPUT VOLTAGE IN CONTINUOUS MODE

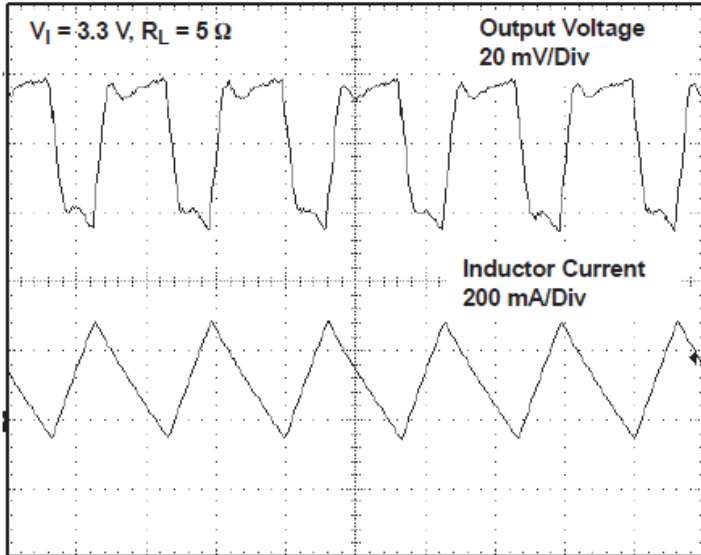

OUTPUT VOLTAGE IN POWER SAVE MODE

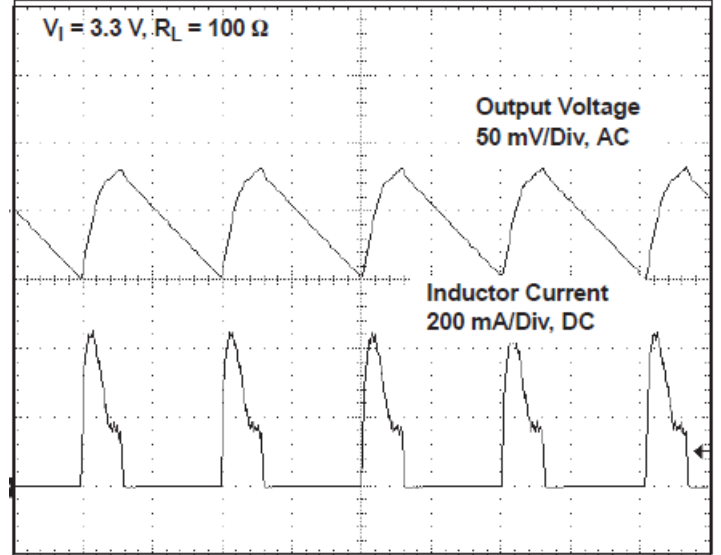

LINE TRANSIENT RESPONSE

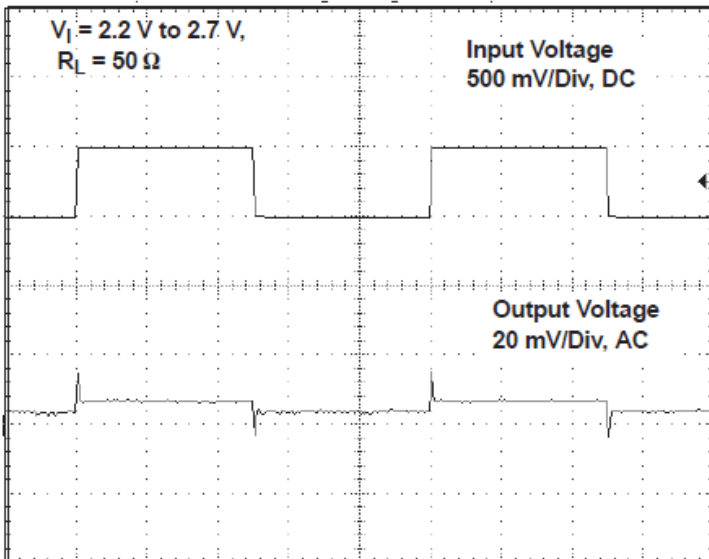

LOAD TRANSIENT RESPONSE

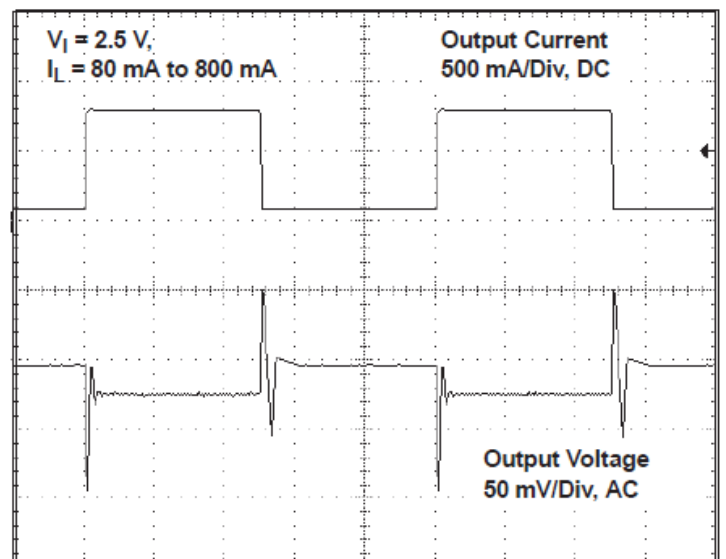



### Typical Operating Characteristics(Cont.)

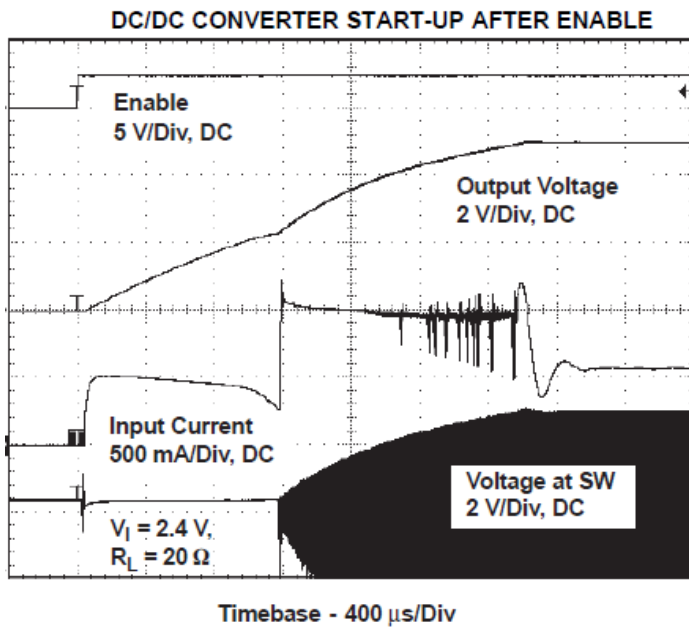

Type Application Circuit

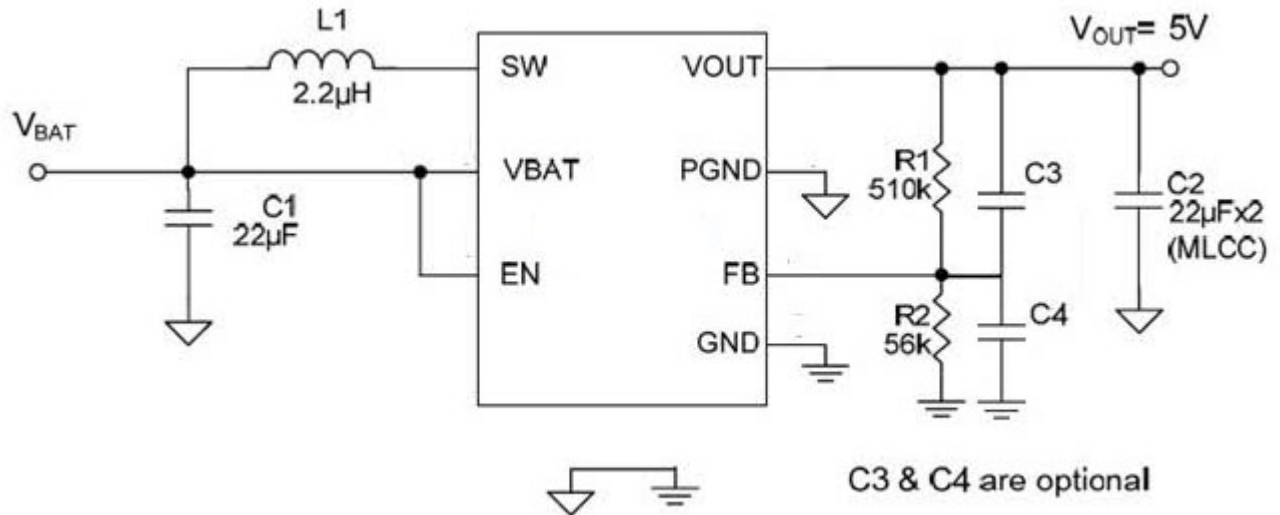

## Function Description

### Main Control Loop

The HM5188 is a constant frequency, synchronous rectifier, and current-mode switching regulator. In normal operation, the internal N-channel power MOSFET is turned on each cycle when the oscillator sets an internal RS latch and turned off when an internal comparator (ICMP) resets the latch. The peak inductor current which ICMP resets the RS latch is controlled by the voltage on the COMP node, which is the output of the error amplifier (EAMP). An external resistive divider connected between  $V_{OUT}$  and ground allows the EAMP to receive an output feedback voltage  $V_{FB}$  at FB pin. When the load current increases, it causes a slightly decrease in  $V_{FB}$  relative to the 0.5V reference, which in turn causes the COMP voltage to increase until the average inductor current matches the new load current.

### Start-up

A start-up oscillator circuit is integrated in the HM5188. When the device enables, the circuit pumps the output voltage high. Once the output voltage reaches 1.6V (typ), the main DC-DC circuitry turns on and boosts the output voltage to the final regulation voltage.

### Automatic PFM/PWM mode Switch

The HM5188 is a fixed frequency PWM peak current modulation control step-up converter. At light loads, the HM5188 will automatically enter in pulse frequency modulation operation to reduce the dominant switching losses. In PFM operation, the inductor current may reach zero or reverse on each pulse. A zero current comparator turns off the P-channel synchronous MOSFET, forcing DCM(Discontinuous Current Mode) operation at light load. These controls get very low quiescent current, help to maintain high efficiency over the complete load range.

### Synchronous Rectification

The internal synchronous rectifier eliminates the need for an external Schottky diode, thus reducing cost and board space. During the cycle off-time, the P-FET turns on and shunts the

external component. Conversion efficiency can be as high as 92%.

### Load Disconnect

Driving EN to ground places the HM5188 in shutdown mode. When in shutdown, the internal power MOSFET turns off, all internal circuitry shuts down and the quiescent supply current reduces to 1 $\mu$ A maximum.

A special circuit is applied to disconnect the load from the input during shutdown the converter. In conventional synchronous rectifier circuits, the back-gate diode of the highside P-FET is forward biased in shutdown and allows current flowing from the battery to the output. However, this device uses a special circuit, which takes the cathode of the back-gate diode of the high-side P-FET and disconnects it from the source when the regulator is shutdown. The benefit of this feature for the system design engineer is that the battery is not depleted during shutdown of the converter. No additional components must be added to the design to make sure that the battery is disconnected from the output of the converter.

### Current-Limit Protection

The HM5188 monitors the inductor current, flowing through the N-FET, and limits the current peak at currentlimit level to prevent loads and the HM5188 from damages during overload conditions.

### Over-Temperature Protection (OTP)

The over-temperature circuit limits the junction temperature of the HM5188. When the junction temperature exceeds 150 $^{\circ}$ C, a thermal sensor turns off the both N-FET and P-FET, allowing the devices to cool. The thermal sensor allows the converters to start a soft-start process and regulate the output voltage again after the junction temperature cools by 30 $^{\circ}$ C. The OTP is designed with a 30 $^{\circ}$ C hysteresis to lower the average Junction Temperature (T<sub>J</sub>) during continuous thermal overload conditions, increasing the lifetime of the device.

FET body diode. As a result, the synchronous rectifier significantly improves efficiency without the addition of an

## Package Information

### ESOP-8

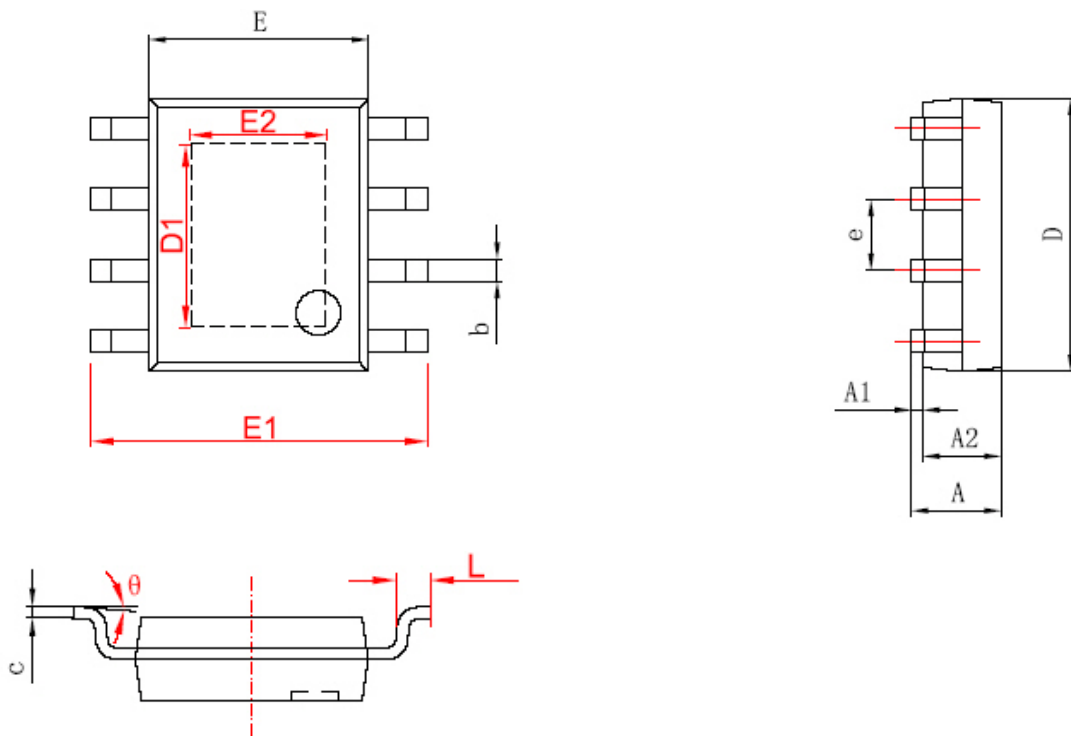

	Dimensions In Millimeters		Dimensions In Inches	
	Min	Max	Min	Max
A	1.350	1.750	0.053	0.069
A1	0.050	0.150	0.004	0.010
A2	1.350	1.550	0.053	0.061
b	0.330	0.510	0.013	0.020
c	0.170	0.250	0.006	0.010
D	4.700	5.100	0.185	0.200
D1	3.202	3.402	0.126	0.134
E	3.800	4.000	0.150	0.157
E1	5.800	6.200	0.228	0.244
E2	2.313	2.513	0.091	0.099
e	1.270 (BSC)		0.050 (BSC)	
L	0.400	1.270	0.016	0.050
θ	0°	8°	0°	8°