

SYNCHRONOUS BOOST CONVERTER

With 6A Switch, Can Output 5V 2.5A with Li-Battery Input

GENERAL DESCRIPTION

HM5177/HM5177A is a high efficiency synchronous boost regulator that converts down to 2.5V input and 5V output voltage. It adopts NMOS for the main switch and PMOS for the synchronous switch. It can disconnect the output from input during the shutdown mode..

It integrates 6A power MOSFET and can output 5V 2.5A with Li-Battery input.

FEATURES

- 2.5V Minimum input voltage
- Adjustable output voltage
- 6A peak current limit
- Input under voltage lockout
- 600Khz fixed Switching Frequency
- Load disconnect during shutdown
- Integrated soft-start
- Output over voltage protection
- 30mohm Power MOSFET
- Thermal Shutdown
- SOP8-PP Package

APPLICATIONS

Handheld Devices

Power Bank

All Single Cell Li or Dual Cell Battery Operated Products

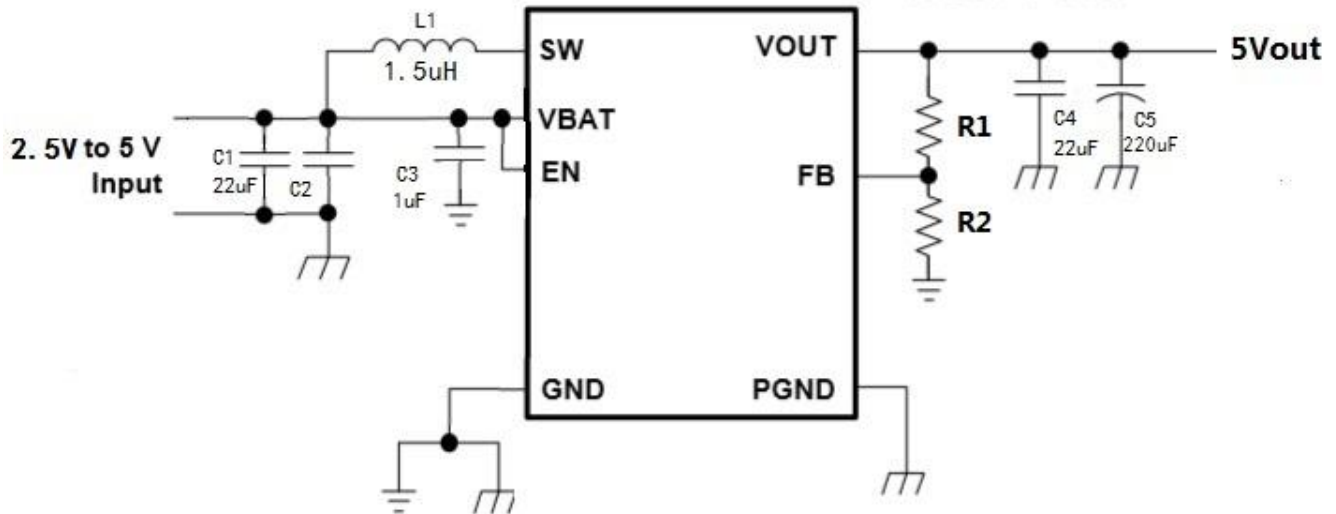

Figure 1. Typical Application Circuit

ORDERING INFORMATION

PART NUMBER	TEMP RANGE	SWICHING FREQUENCY	OUTPUT VOLTAGE (V)	ILIM (A)	PACKAGE	PINS
HM5177/HM5177A	-40°C to 85°C	600KHZ	ADJ	>6	SOP-PP	8

HM5177 & HM5177A has the same top marks , but different in product name pasted on packages.

PIN CONFIGURATION

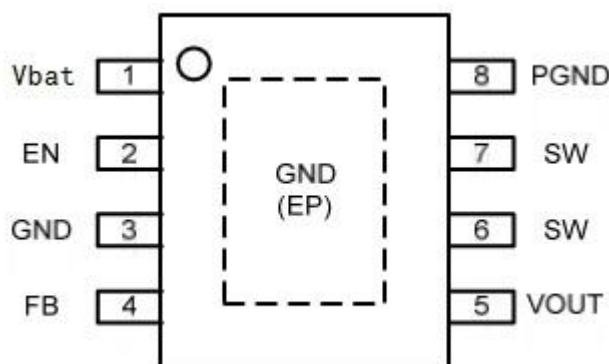

Figure 2. PIN Configuration (TOP View)

PIN DESCRIPTION

PIN NUMBER	PIN NAME	PIN DESCRIPTION
1	Vbat	VDD Power Supply , need one 1uF MLCC close to VBAT pin and AGND
2	EN	Shutdown control input., Connect this pin to logic high level to enable the device
3	AGND	Analog ground
4	FB	Feedback pin
5	Vout	DC-DC Boost output
6,7	SW	Switch pin , Connect an inductor between IN pin and LX pin.
8	PGND	Power ground
9	EPAD	GND and Thermal Pad

ABSOLUTE MAXIMUM RATINGS

(Note: Do not exceed these limits to prevent damage to the device. Exposure to absolute maximum rating conditions for long periods may affect device reliability.)

PARAMETER	VALUE	UNIT
EN Voltage	Vout+0.3V	V

Other Pins	6V	V
Operating Ambient Temperature	-40 to 85	°C
Maximum Junction Temperature	150	°C
Storage Temperature	-55 to 150	°C
Lead Temperature (Soldering, 10 sec)	300	°C

ELECTRICAL CHARACTERISTICS

($V_{IN} = 3.6V$, $T_A = 25^\circ C$ unless otherwise specified)

PARAMETER	SYMBOL	TEST CONDITIONS	MIN	TYP	MAX	UNIT
Input Voltage Range	V_{IN}		2.5		5.3	V
Boost output voltage range	V_{out}		2.5		5.3	V
UVLO Threshold	V_{UVLO}	$V_{HYSTERESIS} = 100mV$		2.2		V
Operating Supply Current	I_{SUPPLY}	$V_{FB} = 1.3V$, $EN = V_{in} = 3.6V$, $I_{Load} = 0$		85		μA
Shutdown Supply Current		$V_{EN} = 0V$, $V_{IN} = 3.6V$			1	
Regulated Feedback Voltage	V_{FB}		1.18	1.2	1.22	V
Peak inductor Current limit (N-MOSFET current limit)	I_{lim}		6			A
Oscillator Frequency	F_{OSC}			0.6		MHz
Rds(ON) of N-channel FET		$I_{SW} = -100mA$		30		mOhm
Enable Threshold		$V_{IN} = 2.V$ to $5V$	0.3	1	1.5	V
Enable Leakage Current			-0.1		0.1	μA
SW Leakage Current		$V_{EN} = 0V$, $V_{SW} = 0V$ or $5V$, $V_{IN} = 5V$			1	μA
Output over voltage protection				5.4		V
Minimum on time				100		ns
Minimum off time				100		ns
Soft Start Time	T_{SS}			1.5		ms

HM5177A has over current protection function、 short-circuit protect function、 Anti-intrusion function and hasn't test mode.

HM5177 has test mode 、 over current protection function and hasn't short-circuit protect function、 Anti-intrusion function.

For HM5177, its EN high voltage from MCU had better being 2V~2.5V to resume $V_{en} < V_{bat}$
 For HM5177A, the EN high voltage only need to be higher than 2V, it can be set from 2V~5V and isn't relative with V_{bat} directly.

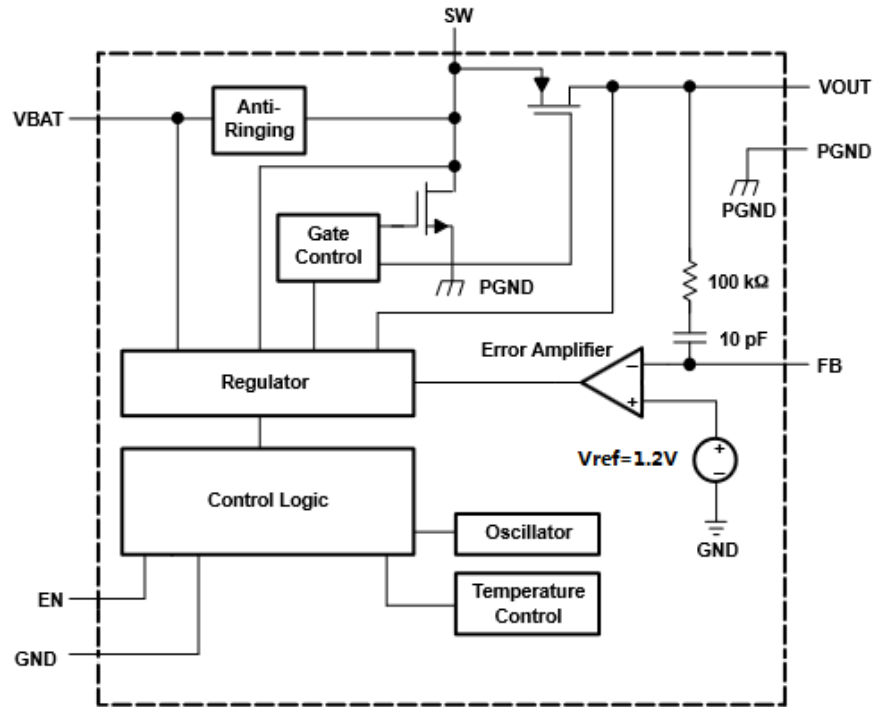

Figure 3. Functional Block Diagram

CONTROLLER CIRCUIT

The controller circuit of the device is based on a fixed frequency multiple feedforward controller topology. Input voltage, output voltage, and voltage drop on the NMOS switch are monitored and forwarded to the regulator. So changes in the operating conditions of the converter directly affect the duty cycle and must not take the indirect and slow way through the control loop and the error amplifier. The control loop, determined by the error amplifier, only has to handle small signal errors. The input for it is the feedback voltage on the FB pin, the voltage on the internal resistor divider. It is compared with the internal reference voltage to generate an accurate and stable output voltage.

The peak current of the NMOS switch is also sensed to limit the maximum current flowing through the switch and the inductor. The typical peak current limit is set to exceed 6A. An internal temperature sensor prevents the device from getting overheated in case of excessive power dissipation.

SYNCHRONOUS RECTIFIER

The device integrates an N-channel and a P-channel MOSFET transistor to realize a synchronous rectifier. Because the commonly used discrete Schottky rectifier is replaced with a low RDS(ON) PMOS switch, the power conversion efficiency reaches 96%. To avoid ground shift due to the high currents in the NMOS switch, two separate ground pins are used. The reference for all control functions is the GND pin. The source of the NMOS switch is connected to PGND. Both grounds must be connected on the PCB at only one point close to the GND pin. A special circuit is applied to disconnect the load from the input during shutdown of the converter. In conventional synchronous rectifier circuits, the backgate diode of the high-side PMOS is forward biased in shutdown and allows current flowing from the battery to the output. This device however uses a special circuit which takes the cathode of the backgate diode of the high-side PMOS and disconnects it from the source when the regulator is not enabled (EN = low).

The benefit of this feature for the system design engineer is that the battery is not depleted during shutdown of the converter. No additional components have to be added to the design to make sure that the battery is disconnected from the output of the converter.

OUTPUT VOLTAGE PROGRAMMING

In the adjustable version, the output voltage is set by a resistive divider according to the following equation:

$$R_1 = R_2 \times \left(\frac{V_{OUT}}{1.2} - 1 \right)$$

Typically choose R2=100K and determine R1 from the following equation.

INDUCTOR SELECTION

In normal operation, the inductor maintains continuous current to the output. The inductor current has a ripple that is dependent on the inductance value. The high inductance reduces the ripple current. For power bank application, 1uH~2.2uH is suitable.

SELECTED INDUCTOR BY ACTUAL APPLICATION:

Manufacturer	Part Number	Inductance(uH)	DRC max (Ohms)	Dimensions L*W*H(mm3)
Marata	LQH5BP	1.0	0.019	5*5*2
		1.5	0.024	
		2.2	0.030	
TDK	SPM6530T	1.0	0.007	7.1*6.5*3
		1.5	0.01	

Manufacturer	Part Number	Inductance(uH)	DRC max (Ohms)	Dimensions L*W*H(mm3)
		2.2	0.017	
		3.3	0.027	
WURTH	74437346010	1.0	0.008	7.3*6.6*2.8

Table 1. Recommend Surface Mount Inductors

INPUT CAPACITOR

One or Two 22 μ F MLCC capacitor is recommended to improve transient behavior of the regulator and EMI behavior of the total power supply circuit. Two 22 μ F MLCC capacitor is recommended. One 1 μ F MLCC capacitor is needed close to Vbat.

OUTPUT CAPACITOR

For 5V 2A load, one 22 μ F MLCC+220 μ F E-cap is minim and low ESR tantalum capacitor is recommended

LAYOUT CONSIDERATIONS

1 : The input capacitor, output capacitor, and the inductor should be placed as close as possible to the IC.

2 : Use a common ground node for power ground and a different one for control ground to minimize the effects of ground noise.

3 : The feedback divider should be placed as close as possible to the control ground pin of the IC. The components R1 and R2, and the trace connecting to the FB pin must NOT be adjacent to the SW net on the PCB layout to avoid the noise problem

4 : Please make sure that the big current circuits are board and short to reduce the circuit R_{dson}

5 : The big current path must be broad line in PCB just as below 。 I_{bat} may be big current at startup so it also need broad line. It is desirable to maximize the PCB copper area connecting to GND/EPAD pin to achieve the best thermal and noise performance. If the board space allowed, a ground plane is highly desirable.

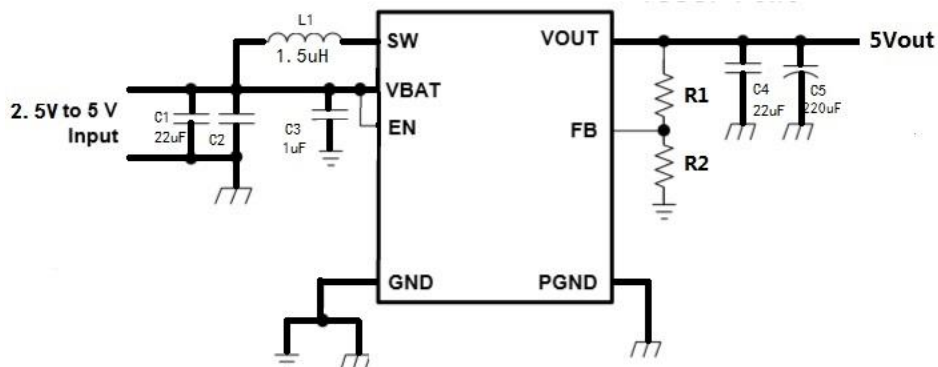

EFFICIENCY FIGURE

(L=1.5uH SPM6530T-1R5, CIN=22uF MLCC*2, COUT=22uF MLCC+220uF E-Cap,if not mentioned)

Efficiency Vs Load Current

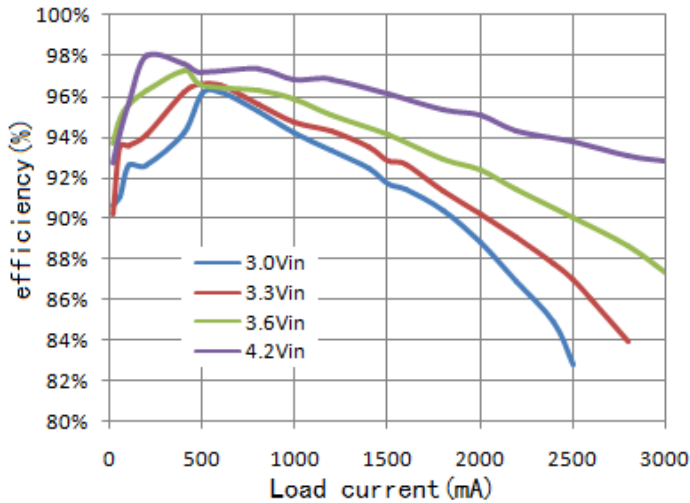

Steady State

(3.6V_{in} 5V_{out} I_o=0A)

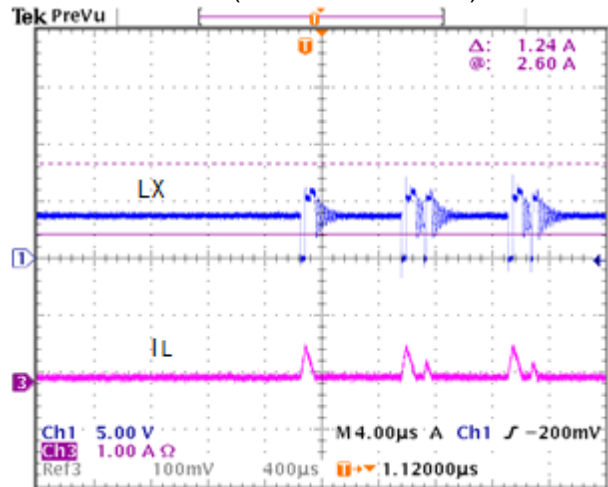

Steady State

(3.6V_{in} 5V_{out} I_o=0.2A)

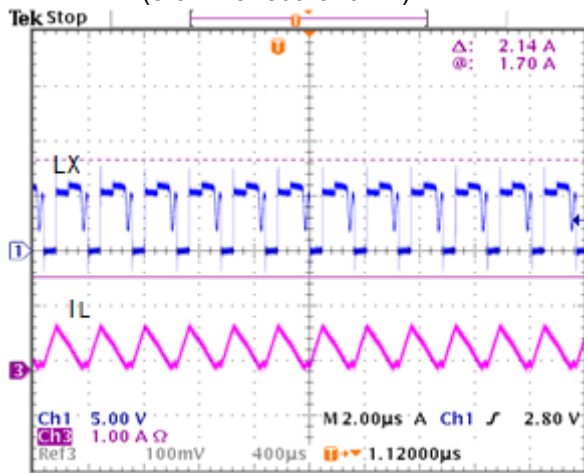

Startup from Vin

(EN, Vin from 0V to 3.6V)

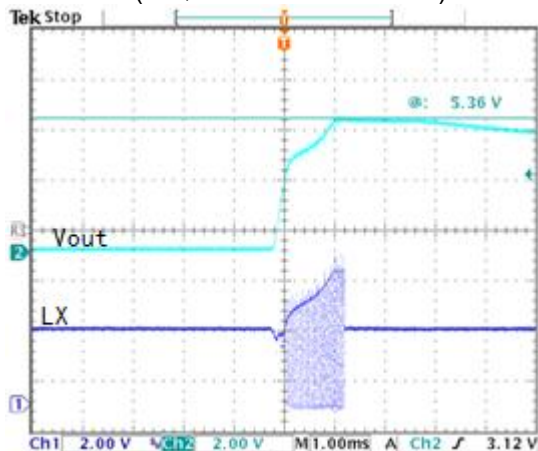

Steady State

(3.6V_{in} 5V_{out} I_o=2A)

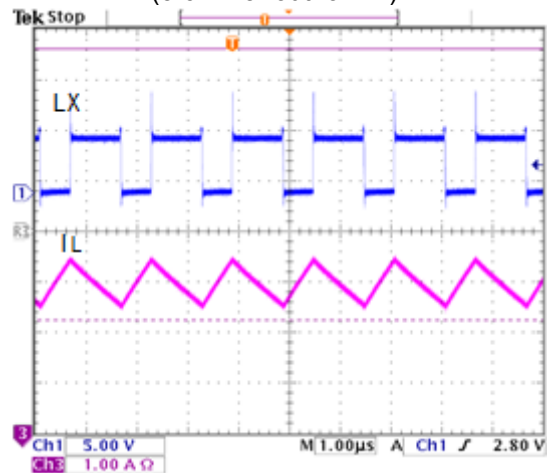

Startup from EN

(Vin=3.6V EN from 0V to 3.6V)

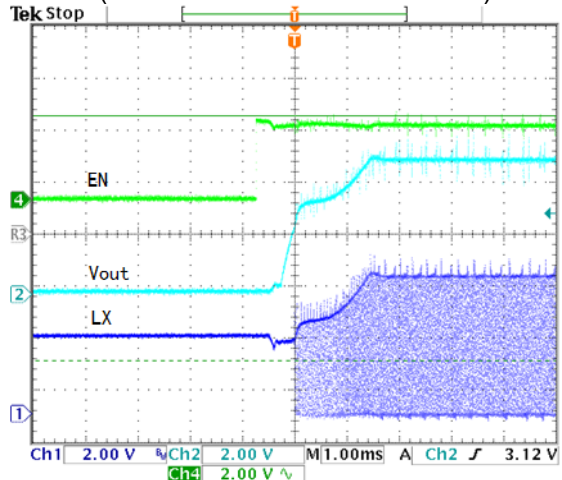

PACKAGE OUTLINE

SOP8-EPAD PACKAGE OUTLINE AND DIMENSIONS

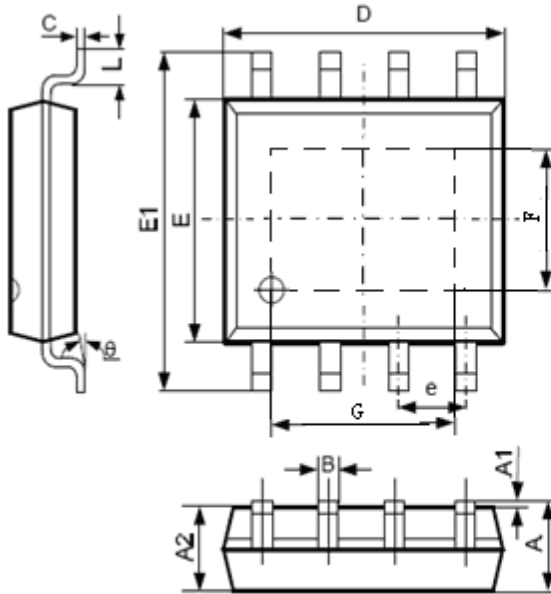

SYMBOL	Dimension in Millimeters		Dimension in Inches	
	MIN	MAX	MIN	MAX
A	1.35	1.75	0.053	0.069
A1	0.100	0.250	0.004	0.010
A2	1.350	1.550	0.053	0.061
B	0.330	0.510	0.013	0.020
C	0.190	0.250	0.007	0.010
D	4.700	5.100	0.185	0.201
E	3.800	4.000	0.150	0.157
E1	5.800	6.300	0.228	0.248
e	1.27 TYP		0.050 TYP	
L	0.400	1.270	0.016	0.050
θ	0°	8°	0°	8°
F	2.26	2.56	0.089	0.101
G	3.15	3.45	0.124	0.136

In order to increase the driver current capability of HM5177/HM5177A and improve the temperature of package, Please ensure Epad and enough ground PCB to release energy.

