GENERAL DESCRIPTION

The HM5459 is a high integrated solution for lithium/polymer battery protection. HM5459 contains advanced power MOSFET, high-accuracy voltage detection circuits and delay circuits. HM5459 is put into an ultra-small SOT23-5 package and only one external component makes it an ideal solution in limited space of battery pack. HM5459 has all the protection functions required in the battery application including over charging, over discharging, over current and load short protection etc. The accurate over charging detection voltage ensures safe and full utilization charging. The low standby current drains little current from the cell while in storage. The device is not only targeted for digital cellular phones, but also for any other Li-Ion and Li-Poly battery-powered information appliances requiring long time battery life.

FEATURES

- Protection of Charger Reverse Connection
- Protection of Battery Cell Reverse Connection
- Integrate Advanced Power MOSFET with Equivalent of 53mΩ RDS(ON)
- Ultra-small SOT23-5 Package
- Only One External Capacitor Required
- Over temperature Protection
- Overcharge Current Protection
- Two-step Over current Detection:
 - Over discharge Current
 - Load Short Circuiting
- Charger Detection Function
- Delay Times are generated inside
- High-accuracy Voltage Detection
- Low Current Consumption
- Operation Mode: 2.8 μ A typ.
- Power-down Mode: 0.1 μ A max.
- RoHS Compliant and Lead (Pb) Free

APPLICATIONS

- One-Cell Lithium-ion Battery Pack
- Lithium-Polymer Battery Pack

PIN CONFIGURATION

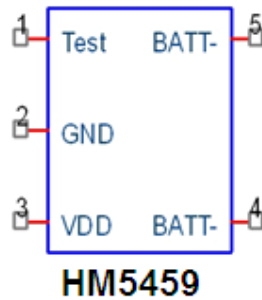

PIN DESCRIPTION

PIN NO.	PIN Name	PIN DESCRIPTION
1	Test	Test pin for reduce delay time
2	GND	Ground
3	VDD	Power Supply
4/5	BATT-	Input pin for current sense, charger detect

TYPICAL APPLICATION CIRCUIT

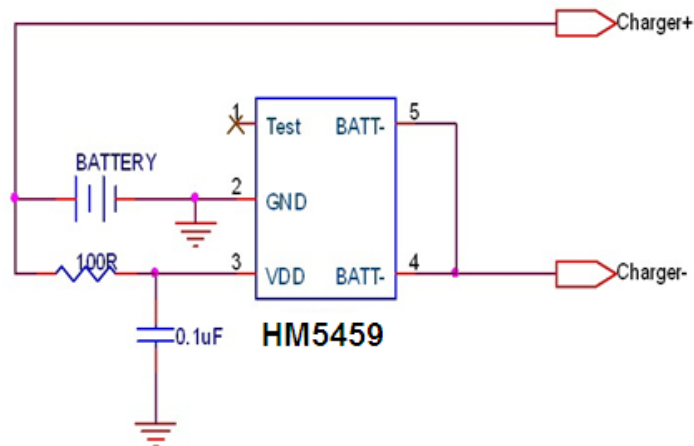

ABSOLUTE MAXIMUM RATINGS

(Note: Do not exceed these limits to prevent damage to the device. Exposure to absolute maximum rating conditions for long periods may affect device reliability.)

PARAMETER	VALUE	UNIT
VDD input pin voltage	-0.3 to 6	V
BATT- input pin voltage	-6 to 12	V
Operating Ambient Temperature	-40 to 85	°C
Maximum Junction Temperature	125	°C
Storage Temperature -55 to 150 °C	-55 to 150	°C
Lead Temperature (Soldering, 10 sec)	300	°C
Power Dissipation at T=25°C	0.4	W

ELECTRICAL CHARACTERISTIC

Typicals and limits appearing in normal type apply for TA = 25°C, unless otherwise specified

Parameter	Symbol	Test Condition	Min	Typ	Max	Unit
Detection Voltage						
Overcharge Detection Voltage	VDET1	Detect rising edge of supply voltage	4.25	4.30	4.35	V
Overcharge Release Voltage	VRET1		4.05	4.10	4.15	V
Over-discharge Detection voltage	VDET2		2.3	2.4	2.5	V
Over-discharge Release Voltage	VRET2		2.9	3.0	3.1	V
Charger Detection Voltage	VCHA		-0.07	-0.12	-0.2	V
Detection Current						
Over-discharge Current Detection	IDET2	VDD=3.0V	2.1	3.0	3.9	A
Load Short-Circuiting Detection	Ishort	VDD=3.6V	10	15	20	A
Power Section						
Supply current	IQ	VDD=3.5V, VM=0V	1.4	2.8	6.0	uA
Standby current	Istandby	VDD=2.0V		0.1	1	uA
FET on Resistance						
Equivalent FET on Resistance	RDS(ON)	VDD=3.6V Iout =1.0A	46	53	60	mΩ
Detection Delay Time						
Output delay of over charge	TVDET1	VDD=3.6V to 4.4V	70	95	155	mS
Output delay of over-discharge	TVDET2	VDD=3.6V to 2.0V	15	23	60	mS
Output delay of excess current	TIDET	VDD=3.5V	6	11	20	mS
Load Short-Circuiting Detection Delay Time	Tshort	VDD=3.5V	100	200	300	uS
Over Temperature Protection						
Over Temperature Protection	TSHD+		100	120	140	°C
Over Temperature Recovery Degree	TSHD-		80	100	120	°C

FUNCTIONAL DESCRIPTION

The HM5459 monitors the voltage and current of a battery and protects it from being damaged due to overcharge voltage, over-discharge voltage, over-discharge current, and short circuit conditions by disconnecting the battery from the load or charger. These functions are required in order to operate the battery cell within specified limits.

The device requires only one external capacitor. The MOSFET is integrated and its $R_{DS(ON)}$ is as low as 53m Ω typical.

Overcharge Condition

When the battery voltage becomes higher than the overcharge detection voltage (V_{DET1}) during charging under normal condition and the state continues for the overcharge detection delay time (V_{DET1}) or longer, the HM5459 turns the charging control FET off to stop charging. This condition is called the overcharge condition. The overcharge condition is released in the following two cases:

1: When the battery voltage drops below the overcharge release voltage (V_{RET1}), the HM5459 turns the charging control FET on and returns to the normal condition.

2: When load is connected and discharging starts, the HM5459 turns the charging control FET on and returns to the normal condition. The release mechanism is as follows: the discharging current flows through an internal parasitic diode of the charging FET immediately after load is connected and discharging starts, and the batt- pin voltage increases about 0.7 V (forward voltage of the diode) from the GND pin voltage momentarily. The HM5459 detects this voltage and releases the overcharge condition. Consequently, in the case that the battery voltage is equal to or lower than the overcharge detection voltage (V_{DET1}), the HM5459 returns to the normal condition immediately, but in the case the battery voltage is higher than the overcharge detection voltage (V_{DET1}), the chip does not return to the normal condition until the battery voltage drops below the overcharge detection voltage (V_{DET1}) even if the load is connected. In addition, if the batt- pin voltage is equal to or lower than the over current 1 detection voltage when load is connected and discharging starts, the chip does not return to the normal condition.

Over-discharge Condition

When the battery voltage drops below the over-discharge detection voltage (V_{DET2}) during discharging under normal condition and it continues for the over-discharge detection delay time (T_{VDET2}) or longer, the HM5459 turns the discharging control FET off and stops discharging. This condition is called over-discharge condition. After the discharging control FET is turned off, the batt- pin is pulled up by the resistor between batt- and VDD in HM5459.

Meanwhile when batt- is bigger than 1.5V (typ.) (the load short-circuiting detection voltage), the current of the chip is reduced to the power-down current (I_{PDN}). This condition is called power-down condition. The batt- and VDD pins are shorted by the resistor in the IC under the over-discharge and power-down conditions. The power-down condition is released, when charger is connected and the potential difference between batt- and VDD becomes 1.3 V (typ.) or higher (load short-circuiting detection voltage). At this time, the FET is still off. When the battery voltage becomes the over-discharge detection voltage (V_{DET2}) or higher (see note), the HM5459 turns the FET on and changes to the normal condition from the over-discharge condition.

Over Current Condition

When the discharging current becomes equal to or higher than a specified value (the batt- pin voltage is equal to or higher than the over current detection voltage) during discharging under normal condition and the state continues for the over current detection delay time or longer, the HM5459 turns off the discharging control FET to stop discharging. This condition is called over current condition. (The over current includes over current, or load short circuiting.) The batt- and GND pins are shorted internally by the resistor under the over current condition. When a load is connected, the batt- pin voltage equals the VDD voltage due to the load. The over current condition returns to the normal condition when the load is released and the impedance between the B+ and B pins becomes higher than the automatic recoverable impedance. When the load is removed, the batt- pin goes back to the GND potential since the batt- pin is shorted the GND pin with the resistor. Detecting that the batt- pin potential is lower than the over current detection voltage (V_{IDET2}), the IC returns to the normal condition.

Abnormal Charge Current Detection

If the batt- pin voltage drops below the charger detection voltage during charging under the normal condition and it continues for the overcharge detection delay time (T_{VDETI}) or longer, the HM5459 turns the charging control FET off and stops charging. This action is called abnormal charge current detection.

Abnormal charge current detection works when the discharging control FET is on and the batt- pin voltage drops below the charger detection voltage. When an abnormal charge current flows into a battery in the over discharge condition, the HM5459 consequently turns the charging control FET off and stops charging after the battery voltage becomes the over discharge detection voltage and the overcharge detection delay time (T_{VDETI}) elapses.

Abnormal charge current detection is released when the voltage difference between batt- pin and GND pin becomes lower than the charger detection voltage by separating the charger.

Load Short-circuiting condition

If voltage of batt- pin is equal or below short circuiting protection voltage, the HM5459 will stop discharging and battery is disconnected from load. The maximum delay time to switch current off is T_{SHORT} . This status is released when voltage of batt- pin is higher than short protection voltage, such as when disconnecting the load.

PACKAGE INFORMATION

SOT23-5 PACKAGE AND DIMENSIONS

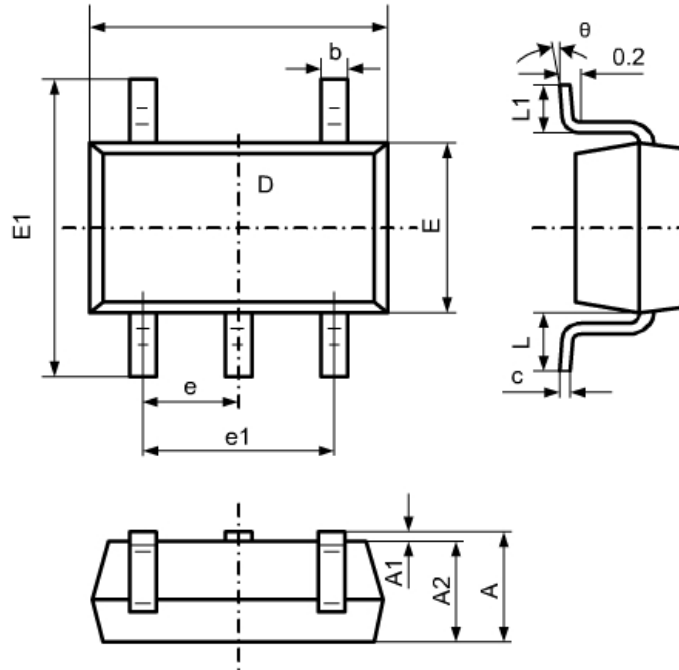

SYMBOL	DIMENSION IN MILLIMETERS		DIMENSION IN INCHES	
	MIN	MAX	MIN	MAX
A	1.050	1.250	0.041	0.049
A1	0.000	0.100	0.000	0.004
A2	1.050	1.150	0.041	0.045
b	0.300	0.500	0.012	0.020
c	0.100	0.200	0.004	0.008
D	2.820	3.020	0.111	0.119
E	1.500	1.700	0.059	0.067
E1	2.650	2.950	0.104	0.116
e	0.950 TYP		0.037 TYP	
e1	1.800	2.000	0.071	0.079
L	0.700 REF		0.028 REF	
L1	0.300	0.600	0.012	0.024
θ	0°	8°	0°	8°