

Features:

- I N-Channel
- I ESD improved Capability
- I Depletion Mode
- I dv/dt rated
- I Pb-free lead plating;ROHS compliant
- I Halogen Free

V_{DSX}	600	V
$I_{DSS,min}$	0.012	A
$R_{DS(ON),max}$	700	Ω

Package : SOT-23

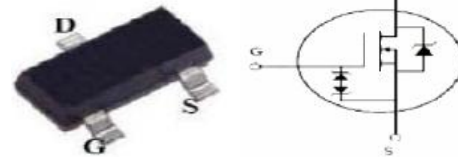

Absolute (Tc= 25°C unless otherwise specified):

Symbol	Parameter	Rating	Units
V_{DSX}	Drain-to-Source Voltage	600	V
I_D	Continuous Drain Current	0.030	A
	Continuous Drain Current T _C =70 °C	0.024	A
I_{DM}^{a1}	Pulsed Drain Current	0.120	A
V_{GS}	Gate-to-Source Voltage	±20	V
dv/dt^{a2}	Peak Diode Recovery dv/dt	5.0	V/ns
P_D	Power Dissipation	0.5	W
$V_{ESD(G-S)}$	Gate source ESD (HBM-C= 100pF, R=1.5k Ω)	300	V
T_J, T_{stg}	Operating Junction and Storage Temperature Range	150, -55 to 150	°C
T_L	Maximum Temperature for Soldering	300	°C

Electrical Characteristics (Tc= 25°C unless otherwise specified):

OFF Characteristics						
Symbol	Parameter	Test Conditions	Rating			Units
			Min.	Typ.	Max.	
V_{DSX}	Drain to Source Breakdown Voltage	$V_{GS}=-5V, I_D=250\mu A$	600	--	--	V
$I_{D(off)}$	Off-state Drain to Source Current	$V_{DS}=600V, V_{GS}=-5V$	--	--	0.1	μA
		$V_{DS}=480V, V_{GS}=-5V$ Ta=125°C			10	μA
$I_{GSS(F)}$	Gate to Source Forward Leakage	$V_{GS}=+10V$	--	--	100	nA
$I_{GSS(R)}$	Gate to Source Reverse Leakage	$V_{GS}=-10V$	--	--	-100	nA

ON Characteristics						
Symbol	Parameter	Test Conditions	Rating			Units
			Min.	Typ.	Max.	
I_{DSS}	On-state drain current	$V_{GS}=0V, V_{DS}=25V$	12			mA
$R_{DS(ON)}$	Drain-to-Source On-Resistance	$V_{GS}=0V, I_D=3mA$	--	350	700	Ω
		$V_{GS}=10V, I_D=16mA$		400	800	
$V_{GS(TH)}$	Gate Threshold Voltage	$V_{DS}=3V, I_D=8.0\mu A$	-2.7	-1.8	-1.0	V

Dynamic Characteristics						
Symbol	Parameter	Test Conditions	Rating			Units
			Min.	Typ.	Max.	
g_{fs}	Forward Transconductance	$V_{DS}=50V, I_D=0.01A$	0.008	0.017	--	S
C_{iss}	Input Capacitance	$V_{GS}=-5V, V_{DS}=25V$ $f=1.0MHz$	--	50		pF
C_{oss}	Output Capacitance		--	4.53		
C_{rss}	Reverse Transfer Capacitance		--	1.08		

Resistive Switching Characteristics						
Symbol	Parameter	Test Conditions	Rating			Units
			Min.	Typ.	Max.	
$t_{d(ON)}$	Turn-on Delay Time	$I_D=0.01A, V_{DD}=300V$ $V_{GS}=-5\sim 7V$ $R_G=6.0\Omega$	--	9.9	--	ns
t_r	Rise Time		--	55.8	--	
$t_{d(OFF)}$	Turn-Off Delay Time		--	56.4	--	
t_f	Fall Time		--	136	--	
Q_g	Total Gate Charge	$I_D=0.01A, V_{DD}=400V$ $V_{GS}=-5V$ to 5V	--	1.14		nC
Q_{gs}	Gate to Source Charge		--	0.5		
Q_{gd}	Gate to Drain ("Miller") Charge		--	0.37		

Source-Drain Diode Characteristics						
Symbol	Parameter	Test Conditions	Rating			Units
			Min.	Typ.	Max.	
I_S	Continuous Source Current (Body Diode)	$T_a=25^\circ C$	--	--	0.025	A
I_{SM}	Maximum Pulsed Current (Body Diode)		--	--	0.100	A
V_{SD}	Diode Forward Voltage	$I_F=16mA, V_{GS}=-5V$	--	--	1.2	V
t_{rr}	Reverse Recovery Time	$I_F=0.01A, T_j=25^\circ C$	--	243	--	ns
Q_{rr}	Reverse Recovery Charge	$di_F/dt=100A/\mu s,$ $V_R=300V$	--	636	--	nC

Symbol	Parameter	Typ.	Units
$R_{\theta JA}$	Junction-to-Ambient	250	$^\circ C/W$

Gate-source Zener diode						
Symbol	Parameter	Test Conditions	Rating			Units
			Min.	Typ.	Max.	
V_{GSO}	Gate-source breakdown voltage	$I_{GS} = \pm 1 \text{mA (Open Drain)}$	20			V
The built-in back-to-back Zener diodes have specifically been designed to enhance not only the device's ESD capability, but also to make them safely absorb possible voltage transients that may occasionally be applied from gate to source. In this respect the Zener voltage is appropriate to achieve an efficient and cost-effective intervention to protect the device's integrity. These integrated Zener diodes thus avoid the usage of external components.						

^{a1}: Repetitive rating; pulse width limited by maximum junction temperature

^{a2}: $I_F = 0.01 \text{A}, di/dt \leq 100 \text{A/us}, V_{DD} \leq BV_{DS}, \text{Start } T_J = 25^\circ \text{C}$

Characteristics Curve:

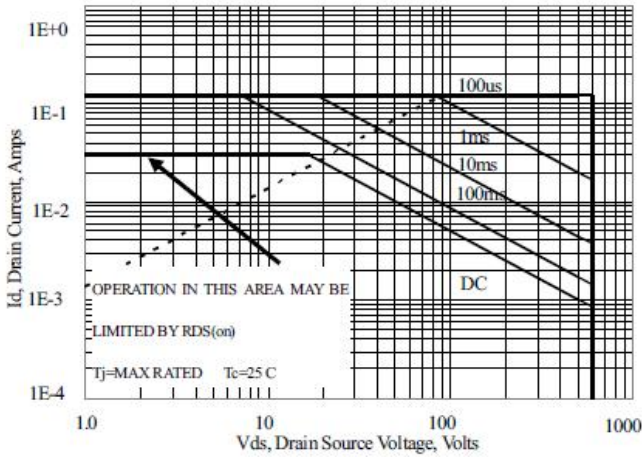

Figure 1 Maximum Forward Bias Safe Operating Area

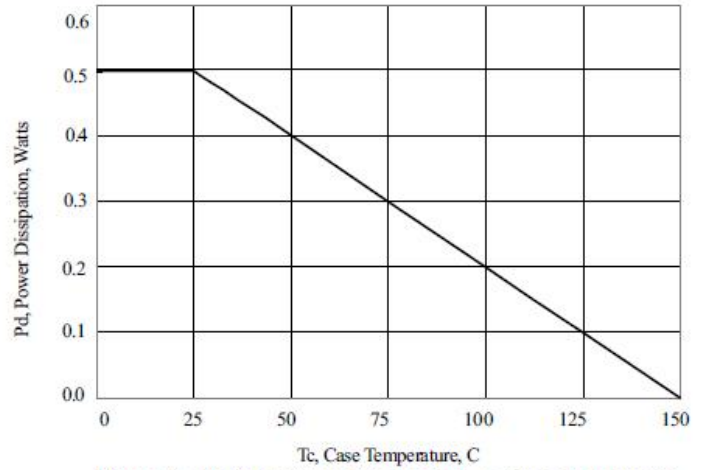

Figure 2 Maximum Power Dissipation vs Case Temperature

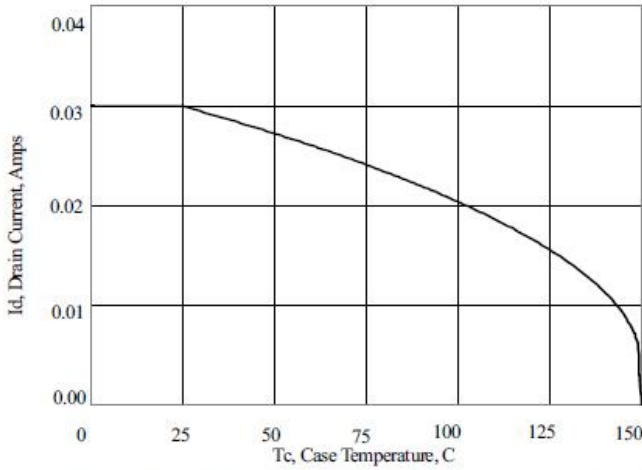

Figure 3 Maximum Continuous Drain Current vs Case Temperature

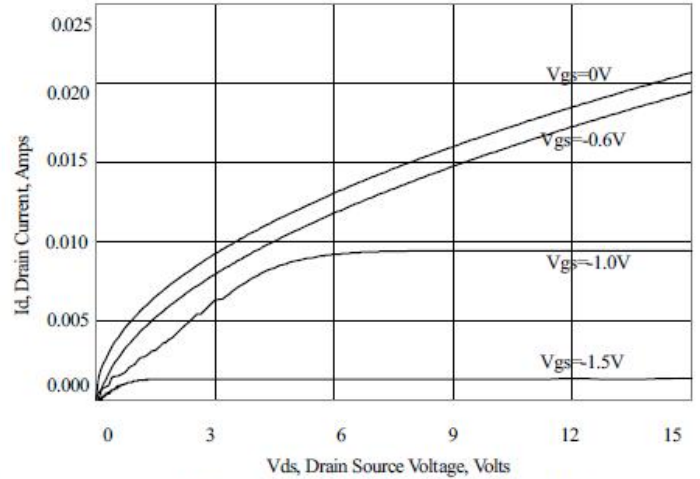

Figure 4 Typical Output Characteristics

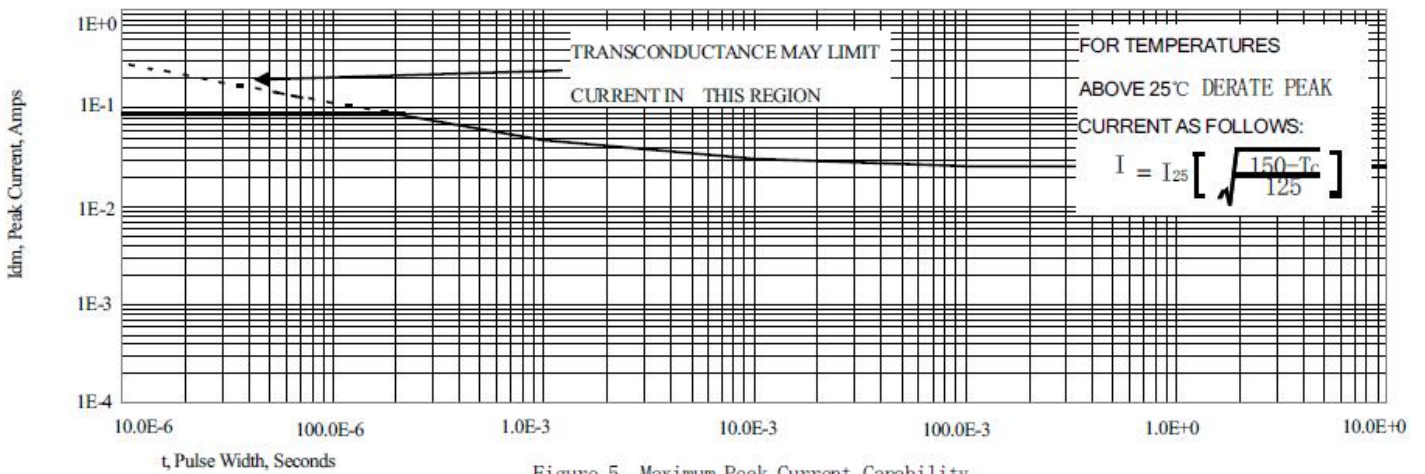

Figure 5 Maximum Peak Current Capability

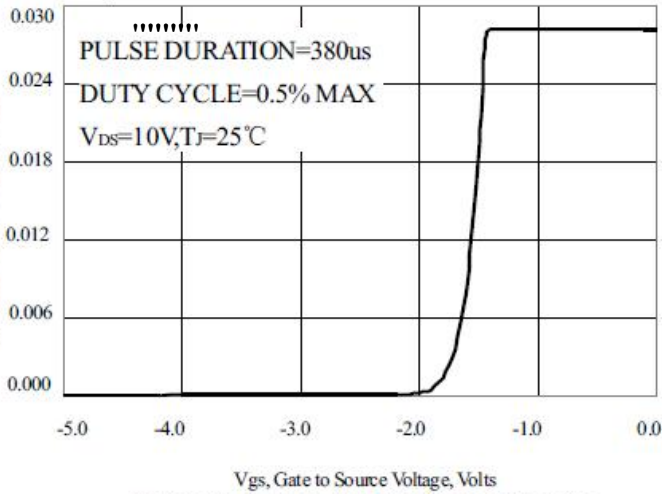

Figure 6 Typical Transfer Characteristics

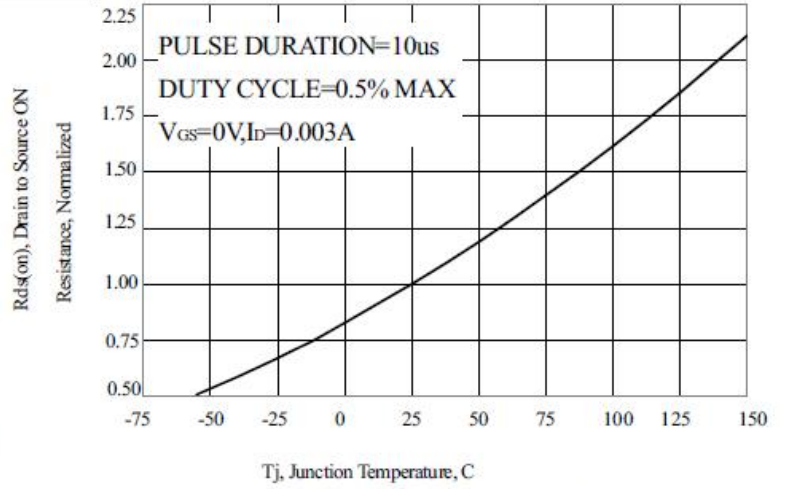

Figure 7 Typical Drain to Source ON Resistance vs Junction Temperature

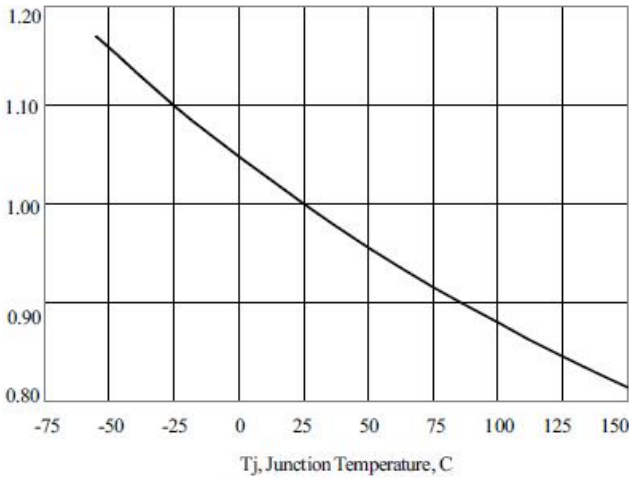

Figure 8 Typical Threshold Voltage vs Junction Temperature

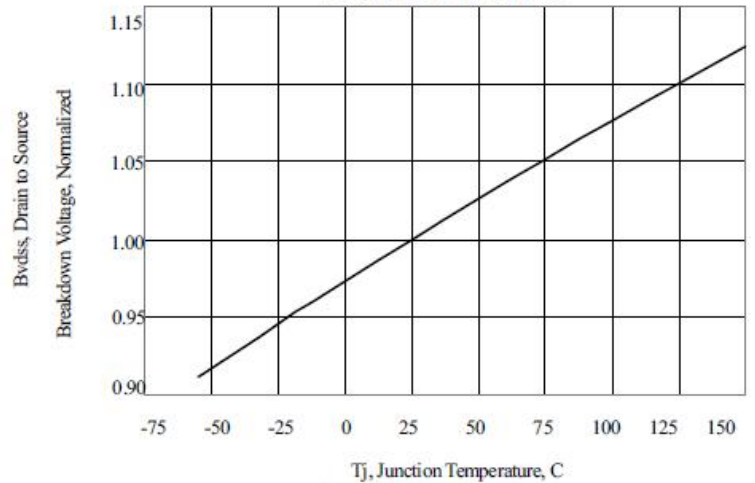

Figure 9 Typical Breakdown Voltage vs Junction Temperature

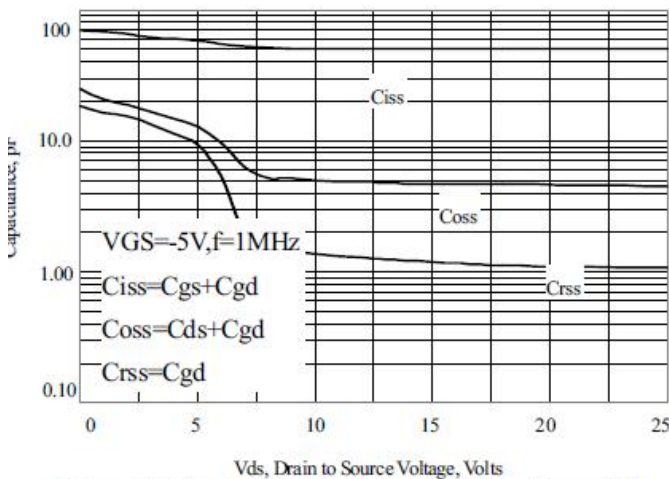

Figure 10 Typical Capacitance vs Drain to Source Voltage

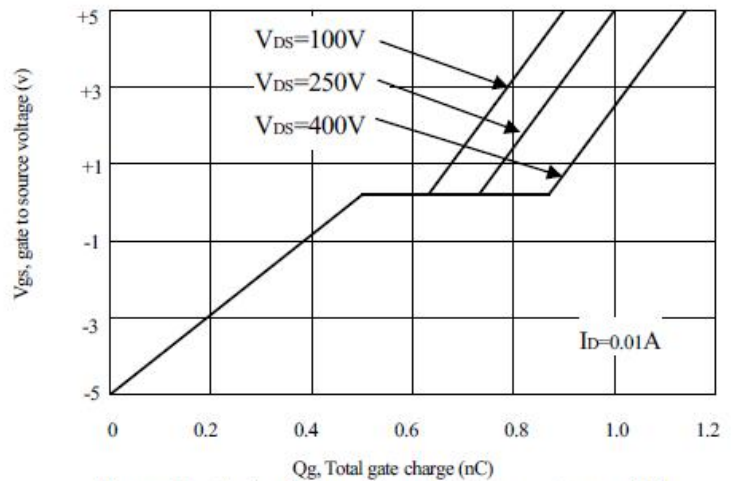

Figure 11 Typical Gate Charge vs Gate to Source Voltage

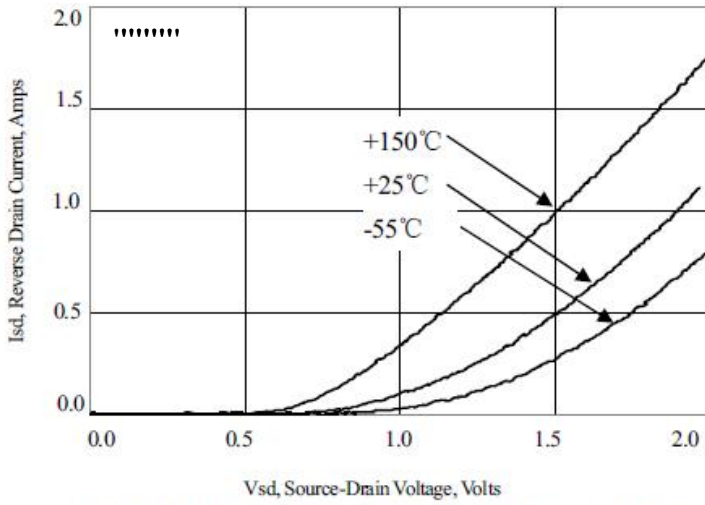
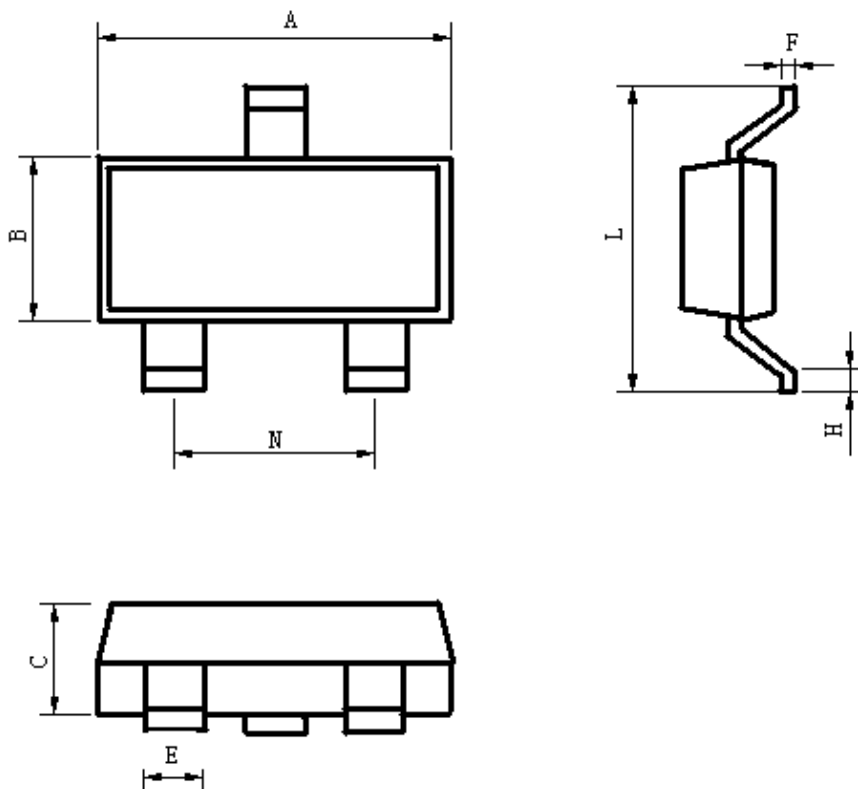

Figure 12 Typical Body Diode Transfer Characteristics

Package Information:



项 目	规范(mm)	
	MIN	MAX
A	2.70	3.10
B	1.20	1.40
C	0.90	1.10
E	0.30	0.50
F	0.05	0.15
H	0.30	0.50
L	2.10	2.70
N	1.80	2.00

SOT-23 Package

.....**The name and content of poisonous and harmful material in products**

Part's Name	Hazardous Substance					
	Pb	Hg	Cd	Cr(VI)	PBB	PBDE
Limit	≤0.1%	≤0.1%	≤0.01%	≤0.1%	≤0.1%	≤0.1%
Lead Frame	○	○	○	○	○	○
Molding Compound	○	○	○	○	○	○
Chip	○	○	○	○	○	○
Wire Bonding	○	○	○	○	○	○
Solder	×	○	○	○	○	○
Note	○: means the hazardous material is under the criterion of SJ/T11363-2006. ×: means the hazardous material exceeds the criterion of SJ/T11363-2006. The plumbum element of solder exist in products presently, but within the allowed range of Eurogroup's RoHS.					

Warnings

1. Exceeding the maximum ratings of the device in performance may cause damage to the device, even the permanent failure, which may affect the dependability of the machine. It is suggested to be used under 80 percent of the maximum ratings of the device.
2. When installing the heatsink, please pay attention to the torsional moment and the smoothness of the heatsink.
3. VDMOSFETs is the device which is sensitive to the static electricity, it is necessary to protect the device from being damaged by the static electricity when using it.
4. This publication is made by H&M SEMI and subject to regular change without notice.