

## N-Channel Super Junction Power MOSFET II

### General Description

The series of devices use advanced super junction technology and design to provide excellent  $R_{DS(ON)}$  with low gate charge. This super junction MOSFET fits the industry's AC-DC SMPS requirements for PFC, AC/DC power conversion, and industrial power applications.

### Features

- New technology for high voltage device
- Low on-resistance and low conduction losses
- Small package
- Ultra Low Gate Charge cause lower driving requirements
- 100% Avalanche Tested
- ROHS compliant

### Application

- Power factor correction (PFC)
- Switched mode power supplies(SMPS)
- Uninterruptible Power Supply (UPS)

$V_{DS@T_{jmax}}$	650	V
$R_{DS(ON) MAX}$	540	mΩ
$I_D$	8	A



**Schematic diagram**

### Package Marking And Ordering Information

Device	Device Package	Marking
HMS8N60D	TO-263	HMS8N60D
HMS8N60	TO-220	HMS8N60
HMS8N60F	TO-220F	HMS8N60F

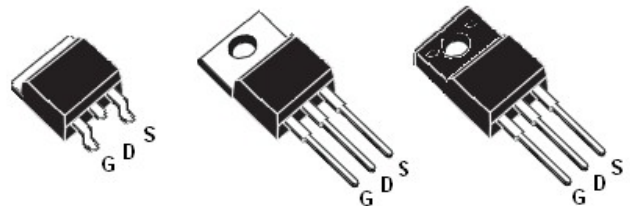

**TO-263**

**TO-220**

**TO-220F**

**Table 1. Absolute Maximum Ratings ( $T_c=25^\circ\text{C}$ )**

Parameter	Symbol	HMS8N60D HMS8N60	HMS8N60F	Unit
Drain-Source Voltage ( $V_{GS}=0V$ )	$V_{DS}$	600		V
Gate-Source Voltage ( $V_{DS}=0V$ )	$V_{GS}$	$\pm 30$		V
Continuous Drain Current at $T_c=25^\circ\text{C}$	$I_{D(DC)}$	8	8*	A
Continuous Drain Current at $T_c=100^\circ\text{C}$	$I_{D(DC)}$	5.2	5.2*	A
Pulsed drain current <b>(Note 1)</b>	$I_{DM(pluse)}$	24	24*	A
Maximum Power Dissipation( $T_c=25^\circ\text{C}$ )	$P_D$	80	31.7	W
Derate above $25^\circ\text{C}$		0.64	0.25	W/ $^\circ\text{C}$
Single pulse avalanche energy <b>(Note 2)</b>	$E_{AS}$	185		mJ
Avalanche current <b>(Note 1)</b>	$I_{AR}$	4		A
Repetitive Avalanche energy , $t_{AR}$ limited by $T_{jmax}$ <b>(Note 1)</b>	$E_{AR}$	0.4		mJ

Parameter	Symbol	HMS8N60D HMS8N60	HMS8N60F	Unit
Drain Source voltage slope, $V_{DS} \leq 480V$ ,	dv/dt	50		V/ns
Reverse diode dv/dt, $V_{DS} \leq 480V, I_{SD} < I_D$	dv/dt	15		V/ns
Operating Junction and Storage Temperature Range	$T_J, T_{STG}$	-55...+150		°C

\* limited by maximum junction temperature

**Table 2. Thermal Characteristic**

Parameter	Symbol	HMS8N60D HMS8N60	HMS8N60F	Unit
Thermal Resistance, Junction-to-Case (Maximum)	$R_{thJC}$	1.56	3.94	°C /W
Thermal Resistance, Junction-to-Ambient (Maximum)	$R_{thJA}$	62	80	°C /W

**Table 3. Electrical Characteristics (TA=25°C unless otherwise noted)**

Parameter	Symbol	Condition	Min	Typ	Max	Unit
<b>On/off states</b>						
Drain-Source Breakdown Voltage	$BV_{DSS}$	$V_{GS}=0V, I_D=250\mu A$	600			V
Zero Gate Voltage Drain Current( $T_c=25^\circ C$ )	$I_{DSS}$	$V_{DS}=600V, V_{GS}=0V$			1	$\mu A$
Zero Gate Voltage Drain Current( $T_c=125^\circ C$ )	$I_{DSS}$	$V_{DS}=600V, V_{GS}=0V$			100	$\mu A$
Gate-Body Leakage Current	$I_{GSS}$	$V_{GS}=\pm 30V, V_{DS}=0V$			$\pm 100$	nA
Gate Threshold Voltage	$V_{GS(th)}$	$V_{DS}=V_{GS}, I_D=250\mu A$	2.5	3	3.5	V
Drain-Source On-State Resistance	$R_{DS(on)}$	$V_{GS}=10V, I_D=4A$		480	540	m $\Omega$
<b>Dynamic Characteristics</b>						
Forward Transconductance	$g_{FS}$	$V_{DS} = 20V, I_D = 4A$		5.5		S
Input Capacitance	$C_{iss}$	$V_{DS}=50V, V_{GS}=0V,$ $F=1.0MHz$		680		pF
Output Capacitance	$C_{oss}$			58		pF
Reverse Transfer Capacitance	$C_{rss}$			4		pF
Total Gate Charge	$Q_g$	$V_{DS}=480V, I_D=8A,$ $V_{GS}=10V$		14.5	22	nC
Gate-Source Charge	$Q_{gs}$			2.8		nC
Gate-Drain Charge	$Q_{gd}$			5.5		nC
Intrinsic gate resistance	$R_G$	$f = 1 MHz$ open drain		2		$\Omega$
<b>Switching times</b>						
Turn-on Delay Time	$t_{d(on)}$	$V_{DD}=380V, I_D=4A,$ $R_G=12\Omega, V_{GS}=10V$		5.5		nS
Turn-on Rise Time	$t_r$			3.5		nS
Turn-Off Delay Time	$t_{d(off)}$			55	75	nS
Turn-Off Fall Time	$t_f$			6.5	10	nS
<b>Source- Drain Diode Characteristics</b>						
Source-drain current(Body Diode)	$I_{SD}$	$T_c=25^\circ C$			8	A
Pulsed Source-drain current(Body Diode)	$I_{SDM}$				23.4	A
Forward On Voltage	$V_{SD}$	$T_j=25^\circ C, I_{SD}=8A, V_{GS}=0V$		0.9	1.2	V
Reverse Recovery Time	$t_{rr}$	$T_j=25^\circ C, I_F=8A, di/dt=100A/\mu s$		220		nS
Reverse Recovery Charge	$Q_{rr}$			2.2		$\mu C$
Peak Reverse Recovery Current	$I_{rrm}$			20		A

Notes 1.Repetitive Rating: Pulse width limited by maximum junction temperature

2.  $T_j=25^\circ C, V_{DD}=50V, V_G=10V, R_G=25\Omega$

**TYPICAL ELECTRICAL AND THERMAL CHARACTERISTICS (curves)**

**Figure1. Safe operating area**

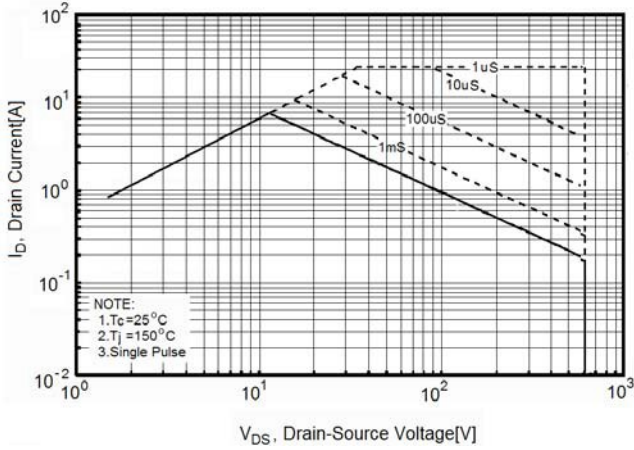

**Figure2. Safe operating area for TO-220F**

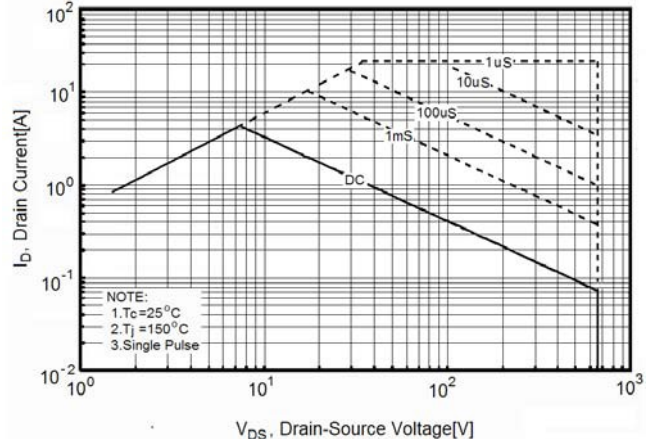

**Figure3. Source-Drain Diode Forward Voltage**

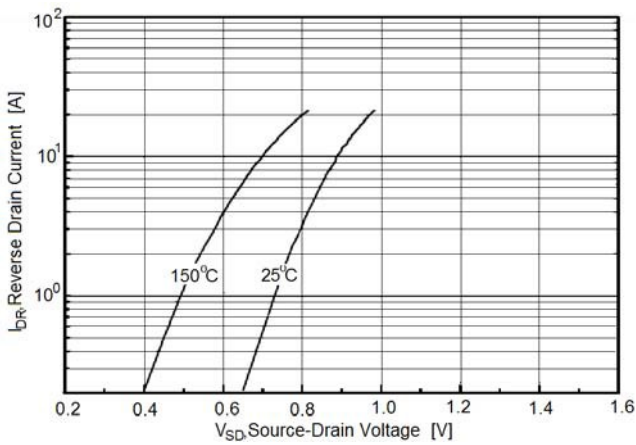

**Figure4. Output characteristics**

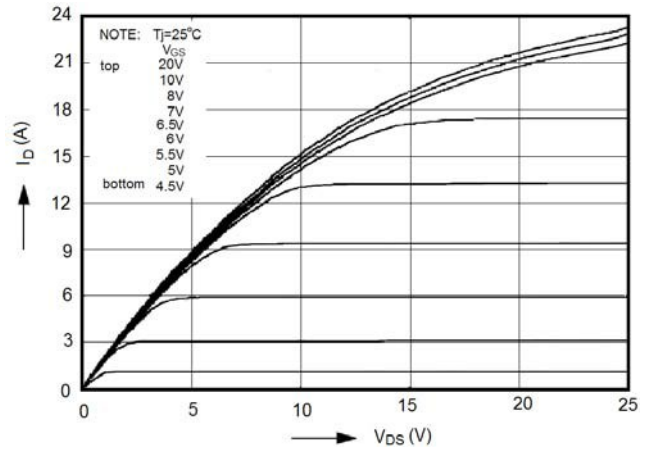

**Figure5. Transfer characteristics**

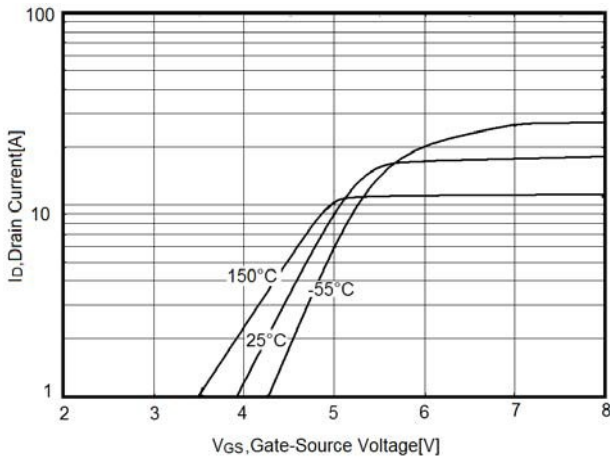

**Figure6. Static drain-source on resistance**

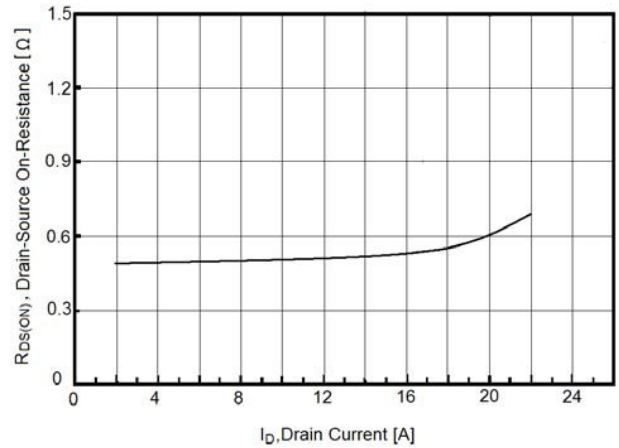

**Figure7.  $R_{DS(ON)}$  vs Junction Temperature**

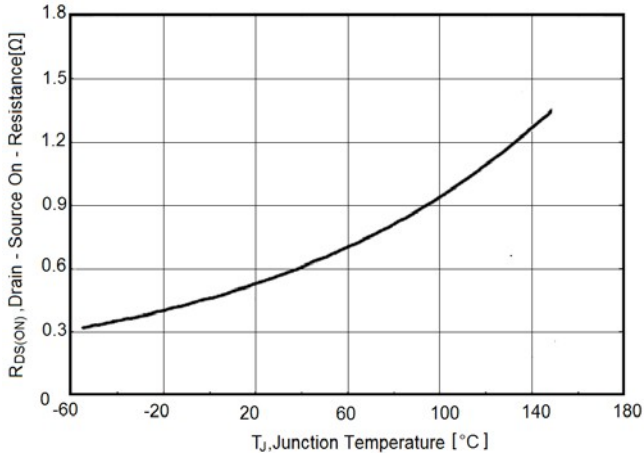

**Figure8.  $BV_{DSS}$  vs Junction Temperature**

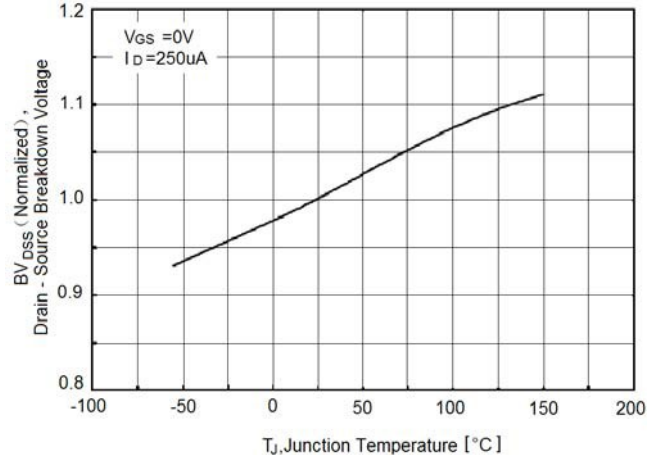

**Figure9. Maximum  $I_D$  vs Junction Temperature**

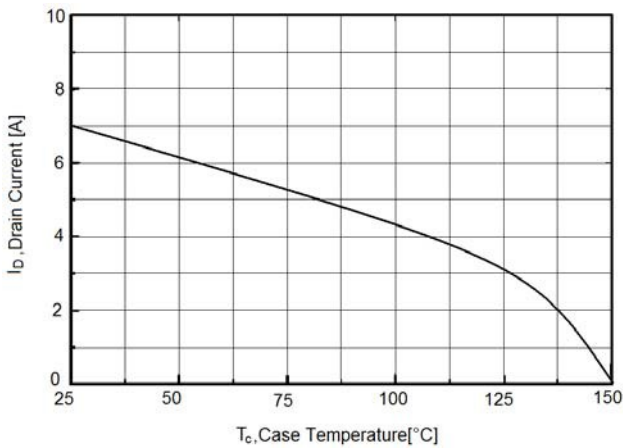

**Figure10. Gate charge waveforms**

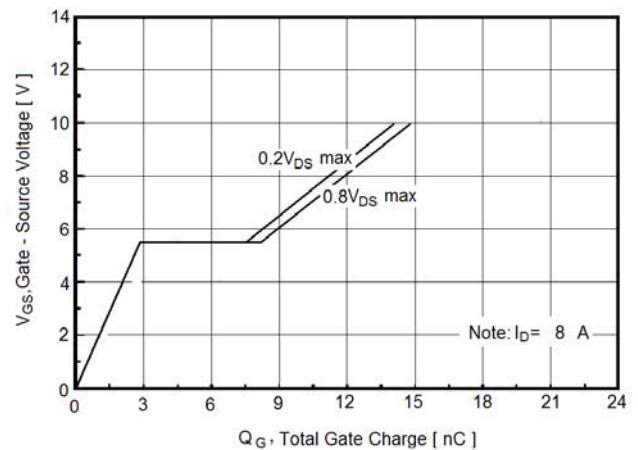

**Figure11. Capacitance**

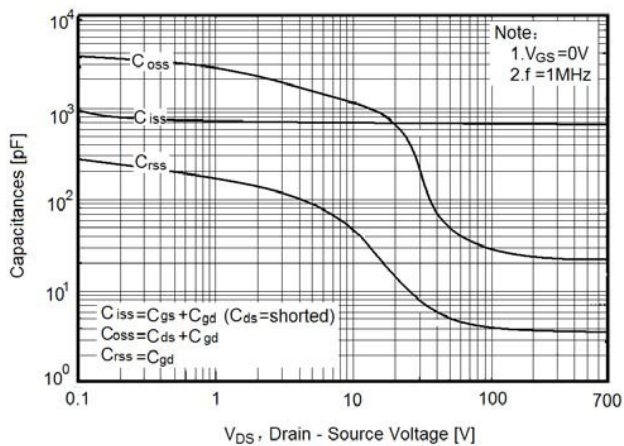

**Figure12. Transient Thermal Impedance**

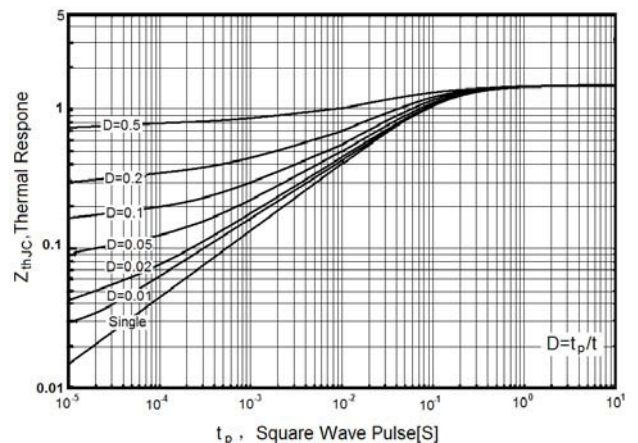
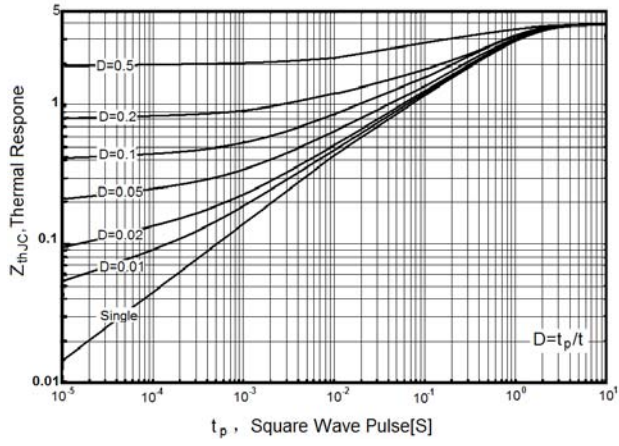
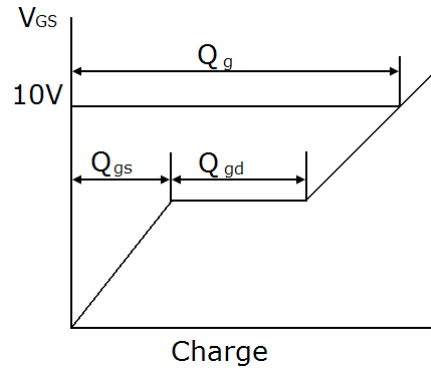
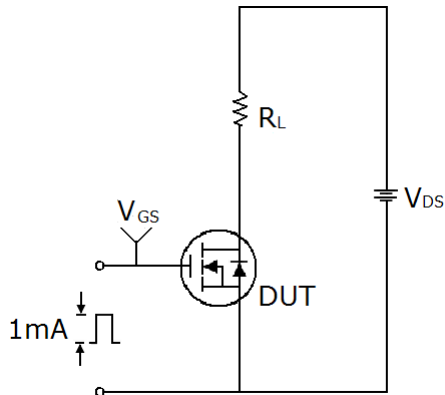

Figure13. Transient Thermal Impedance for TO-220F



## Test circuit

### 1) Gate charge test circuit & Waveform



### 2) Switch Time Test Circuit:

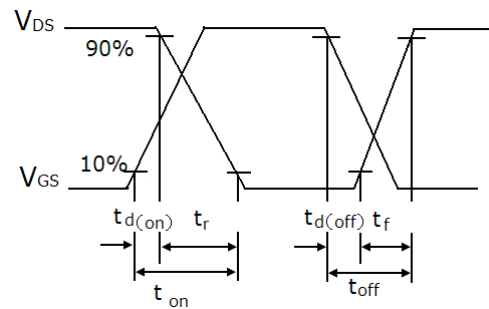
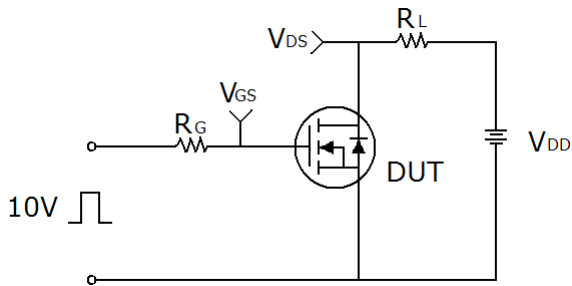

### 3) Unclamped Inductive Switching Test Circuit & Waveforms

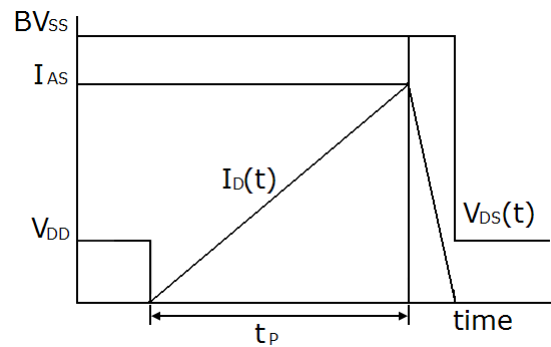
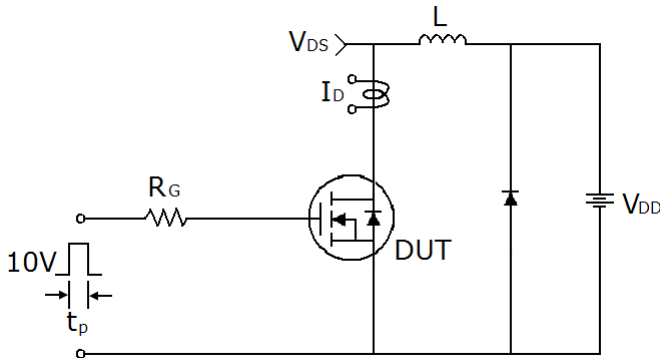

## TO-263-2L Package Information

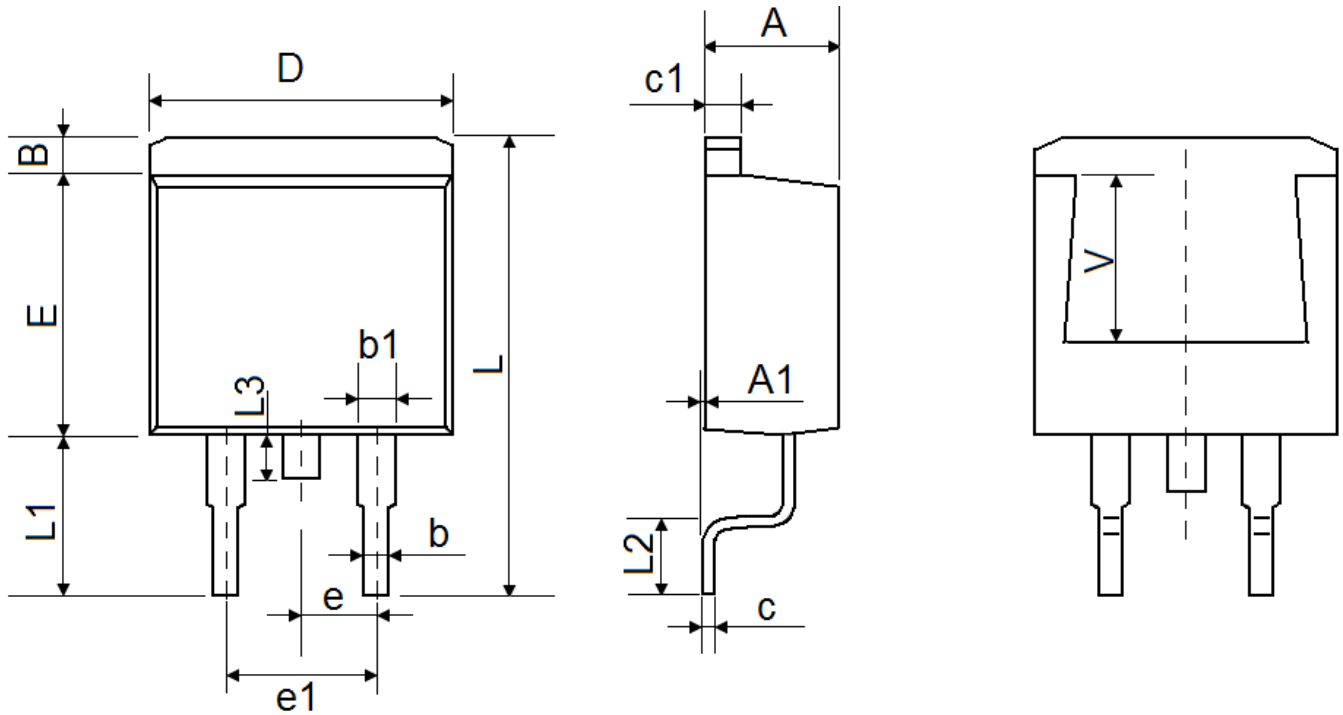

Symbol	Dimensions In Millimeters		Dimensions In Inches	
	Min.	Max.	Min.	Max.
A	4.470	4.670	0.176	0.184
A1	0.000	0.150	0.000	0.006
B	1.170	1.370	0.046	0.054
b	0.710	0.910	0.028	0.036
b1	1.170	1.370	0.046	0.054
c	0.310	0.530	0.012	0.021
c1	1.170	1.370	0.046	0.054
D	10.010	10.310	0.394	0.406
E	8.500	8.900	0.335	0.350
e	2.540 TYP.		0.100 TYP.	
e1	4.980	5.180	0.196	0.204
L	15.050	15.450	0.593	0.608
L1	5.080	5.480	0.200	0.216
L2	2.340	2.740	0.092	0.108
L3	1.300	1.700	0.051	0.067
V	5.600 REF		0.220 REF	

**TO-220-3L-C Package Information**

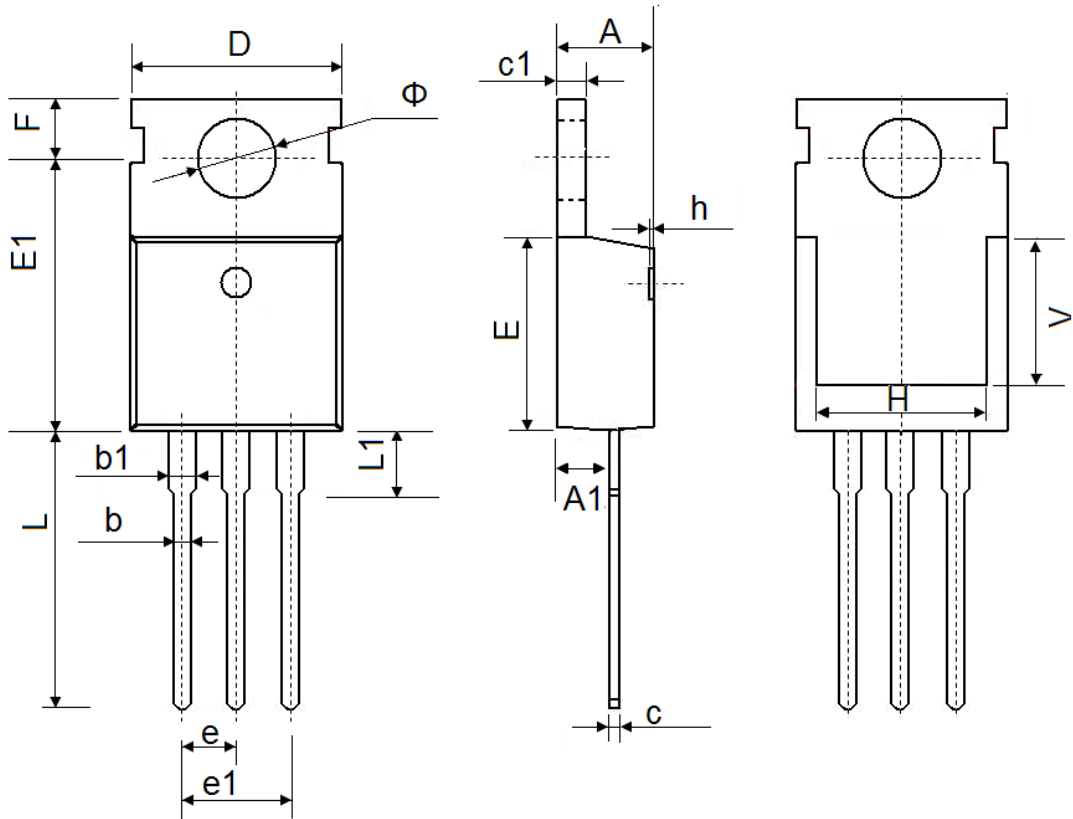

Symbol	Dimensions In Millimeters		Dimensions In Inches	
	Min.	Max.	Min.	Max.
A	4.400	4.600	0.173	0.181
A1	2.250	2.550	0.089	0.100
b	0.710	0.910	0.028	0.036
b1	1.170	1.370	0.046	0.054
c	0.330	0.650	0.013	0.026
c1	1.200	1.400	0.047	0.055
D	9.910	10.250	0.390	0.404
E	8.9500	9.750	0.352	0.384
E1	12.650	12.950	0.498	0.510
e	2.540 TYP.		0.100 TYP.	
e1	4.980	5.180	0.196	0.204
F	2.650	2.950	0.104	0.116
H	7.900	8.100	0.311	0.319
h	0.000	0.300	0.000	0.012
L	12.900	13.400	0.508	0.528
L1	2.850	3.250	0.112	0.128
V	7.500 REF.		0.295 REF.	
φ	3.400	3.800	0.134	0.150



## TO-220F Package Information

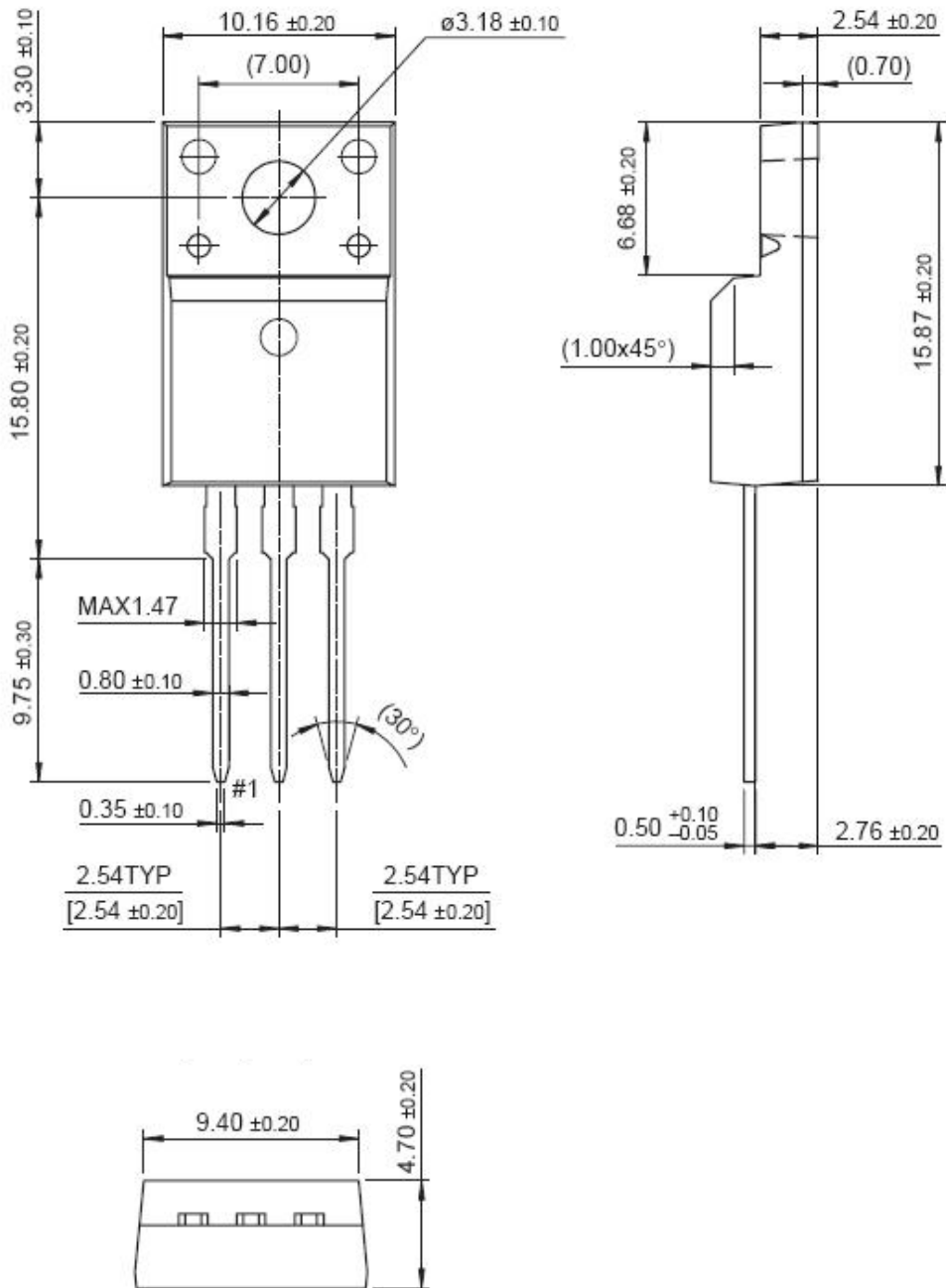

Dimensions in Millimeters