

### Features

- Low start-up voltage: 0.7V (Typ.)
- High efficiency: 85% (Typ.)
- High output voltage accuracy:  $\pm 2.5\%$
- Output voltage: 2.7V, 3.0V, 3.3V, 5.0V
- Output current up to 200mA
- Ultra low supply current  $I_{DD}$ : 5 $\mu$ A (Typ.)
- Low ripple and low noise
- Low shutdown current: 0.5 $\mu$ A (Typ.)
- TO-92, SOT-89, SOT-23 and SOT-25 package

### Applications

- Palmtops/PDAs
- Portable communicators/Smartphones
- Cameras/Camcorders
- Battery-powered equipment

### General Description

The HK77XXA series is a set of PFM step-up DC/DC converter with high efficiency and low ripple. The series features extremely low start-up voltage and high output voltage accuracy. They require only three external components to provide a fixed output voltage of 2.7V, 3.0V, 3.3V or 5.0V. CMOS technology ensures ultra low supply current and makes them ideal for battery-operated applications powered from one or more cells.

The HK77XXA consists of an oscillator, a PFM control circuit, a driver transistor, a reference voltage unit, and a high speed comparator. They employ pulse frequency modulation (PFM) for minimum supply current and ripple at light output loading. These devices are available in space saving TO-92, SOT-89, SOT-23 and SOT-25 packages. For SOT-25 package, it also build-in a chip enable function to reduce power consumption during shutdown mode.

### Selection Table

Part No.	Output Voltage	Package	Marking
HK7727	2.7V	TO-92 SOT-89 SOT-23 SOT-25	HK77XXA (for TO-92)
HK7730	3.0V		HK77XXA# (for SOT-89)
HK7730	3.3V		7XXA# (for SOT-23)
HK7750	5.0V		7XXA# (for SOT-25)

Note: "XX" stands for output voltages.

Only lead free devices are available. "#" stands for lead free devices. For the TO-92 package, there will be a "#" mark at the end of the date code.

### Block Diagram

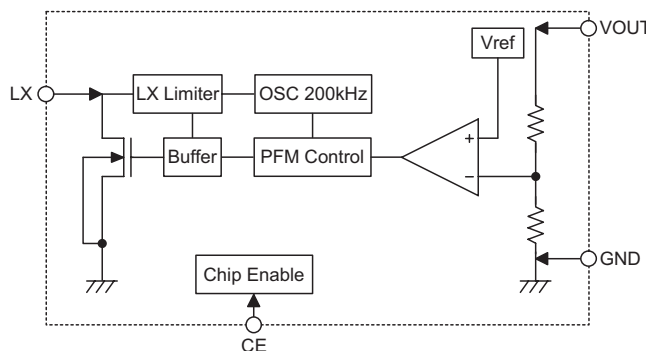

### Pin Assignment

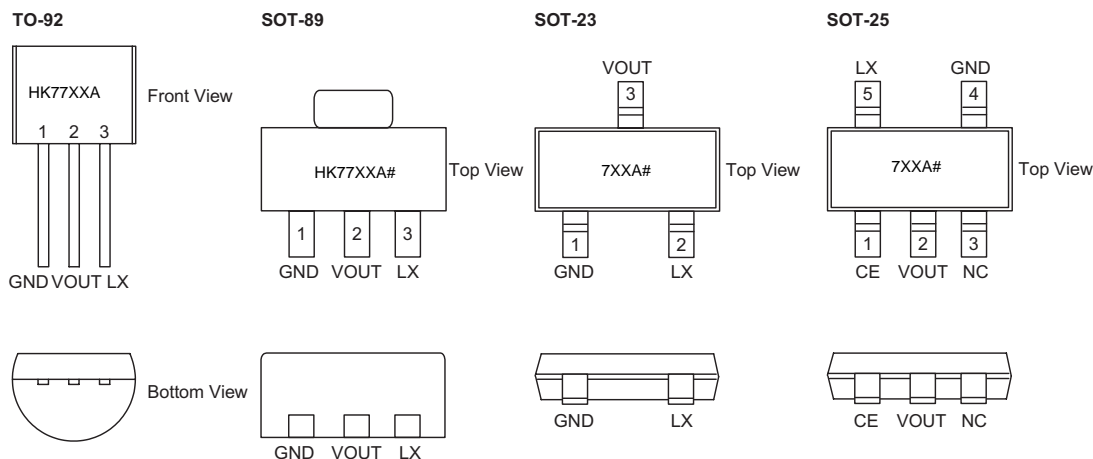

### Pin Description

Pin No.				Pin Name	Description
TO-92	SOT-89	SOT-23	SOT-25		
—	—	—	1	CE	Chip enable pin, high active
2	2	3	2	VOUT	DC/DC converter output monitoring pin
—	—	—	3	NC	No connection
1	1	1	4	GND	Ground pin
3	3	2	5	LX	Switching pin

### Absolute Maximum Ratings

Supply Voltage ..... $V_{SS}-0.3V$  to  $V_{SS}+7V$       Storage Temperature ..... $-50^{\circ}C$  to  $125^{\circ}C$   
Operating Temperature ..... $-40^{\circ}C$  to  $85^{\circ}C$

Note: These are stress ratings only. Stresses exceeding the range specified under "Absolute Maximum Ratings" may cause substantial damage to the device. Functional operation of this device at other conditions beyond those listed in the specification is not implied and prolonged exposure to extreme conditions may affect device reliability.

### Thermal Information

Symbol	Parameter	Package	Max.	Unit
$\theta_{JA}$	Thermal Resistance (Junction to Ambient) (Assume no ambient airflow, no heat sink)	SOT-89	300	$^{\circ}C/W$
		TO-92	300	$^{\circ}C/W$
		SOT-23	330	$^{\circ}C/W$
		SOT-25	320	$^{\circ}C/W$
$P_D$	Power Dissipation	SOT-89	0.33	W
		TO-92	0.33	W
		SOT-23	0.3	W
		SOT-25	0.31	W

Note:  $P_D$  is measured at  $T_a = 25^{\circ}C$

### Electrical Characteristics

$V_{IN}=V_{OUT}\times 0.6$ ;  $I_{OUT}=10\text{mA}$ ;  $T_a=25^\circ\text{C}$  (Unless otherwise specified)

Symbol	Parameter	Test Conditions	Min.	Typ.	Max.	Unit
$V_{IN}$	Input Voltage	—	—	—	6	V
$V_{OUT}$	Output Voltage Tolerance	—	-2.5	—	2.5	%
$V_{START}$	Start-up Voltage (Fig. 1)	$V_{IN}: 0\rightarrow 2\text{V}$ ; $I_{OUT}=1\text{mA}$	—	0.7	0.9	V
$V_{HOLD}$	Minimum Hold-on Voltage (Fig. 1)	$V_{IN}: 2\rightarrow 0\text{V}$ ; $I_{OUT}=1\text{mA}$	—	—	0.7	V
$I_{IN}$	No-load Input Current (Fig. 1)	$I_{OUT}=0\text{mA}$	—	13	26	$\mu\text{A}$
$I_{DD}$	Supply Current (Fig. 2)	$V_S=V_{OUT}+0.5\text{V}$ Measured at $V_{OUT}$ pin	—	5	10	$\mu\text{A}$
$I_{SHDN}$	Shutdown Current	$\text{CE}=\text{GND}$	—	0.5	1	$\mu\text{A}$
$V_{IH}$	CE High Threshold	—	2	—	—	V
$V_{IL}$	CE Low Threshold	—	—	—	0.4	V
$I_{LEAK}$	LX Leakage Current (Fig. 3)	$V_S=V_{OUT}+0.5\text{V}$ , $V_X=6\text{V}$ Measured at the LX pin	—	—	0.9	$\mu\text{A}$
$f_{OSC}$	Maximum Oscillator Frequency (Fig. 3)	$V_S=V_{OUT}\times 0.95$ , $V_X=6\text{V}$ Measured at LX pin	—	200	—	kHz
$D_{OSC}$	Oscillator Duty Cycle (Fig. 3)	$V_S=V_{OUT}\times 0.95$ , $V_X=6\text{V}$ Measured at LX pin	65	75	85	%
$\eta$	Efficiency	—	—	85	—	%

Note: Absolute maximum ratings indicate limits beyond which damage to the device may occur. Operating Ratings indicate conditions for which the device is intended to be functional, but do not guarantee specific performance limits. The guaranteed specifications apply only for the test conditions listed.

### Test Circuit

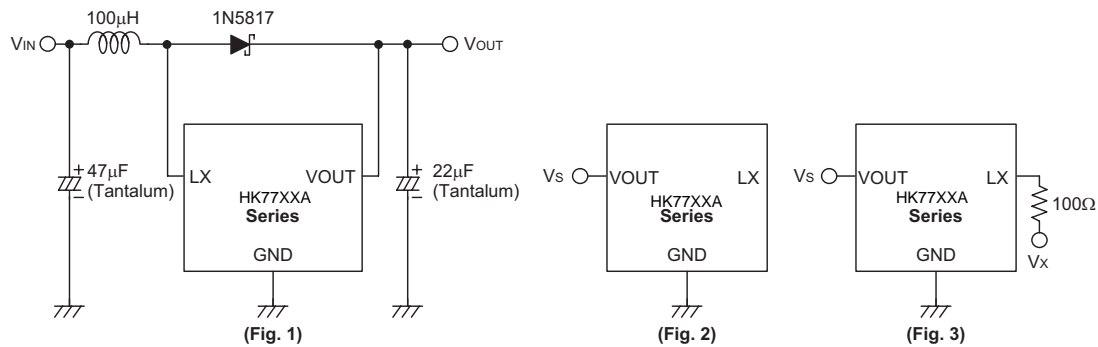

### Typical Performance Characteristics

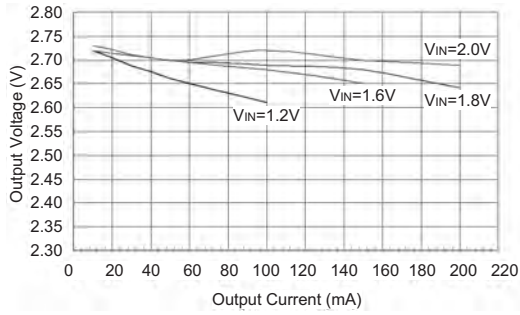

HK77XXA Output Voltage vs Output Current

( $C_{IN}=47\mu\text{F-Tantalum}$ ,  $L=47\mu\text{H}$ ,  $C_{OUT}=22\mu\text{F-Tantalum}$ )

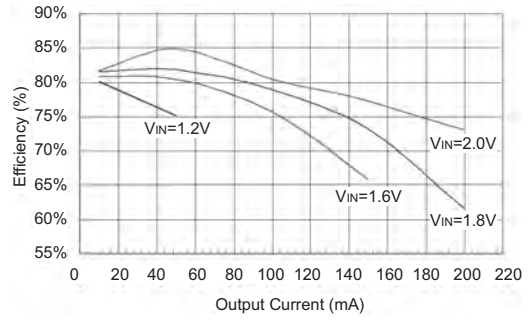

HK77XXA Efficiency vs Output Current

( $C_{IN}=47\mu\text{F-Tantalum}$ ,  $L=47\mu\text{H}$ ,  $C_{OUT}=22\mu\text{F-Tantalum}$ )

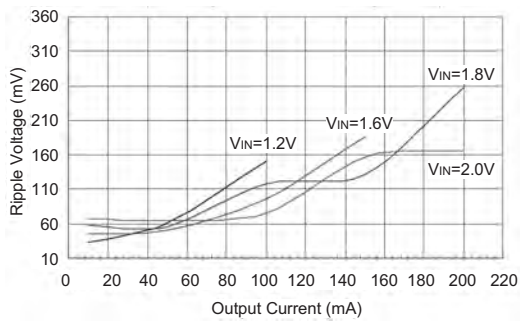

HK77XXA Ripple Voltage vs Output Current

( $C_{IN}=47\mu\text{F-Tantalum}$ ,  $L=47\mu\text{H}$ ,  $C_{OUT}=22\mu\text{F-Tantalum}$ )

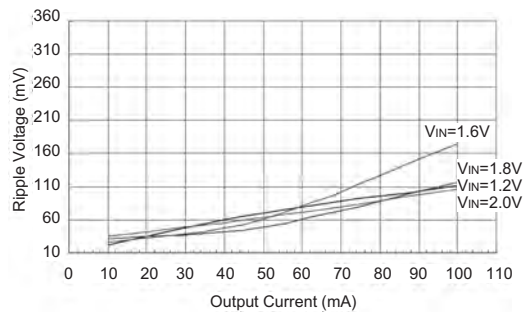

HK77XXA Ripple Voltage vs Output Current

( $C_{IN}=47\mu\text{F-Tantalum}$ ,  $L=100\mu\text{H}$ ,  $C_{OUT}=22\mu\text{F-Tantalum}$ )

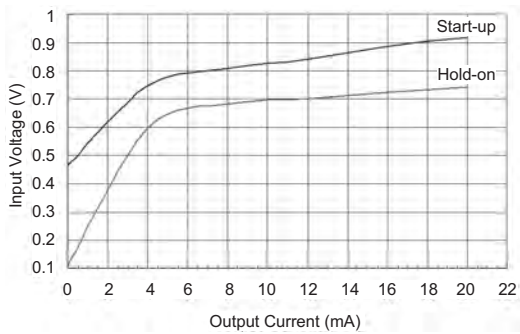

HK77XXA Start-up/Hold-on Voltage

( $C_{IN}=47\mu\text{F-Tantalum}$ ,  $L=47\mu\text{H}$ ,  $C_{OUT}=22\mu\text{F-Tantalum}$ )

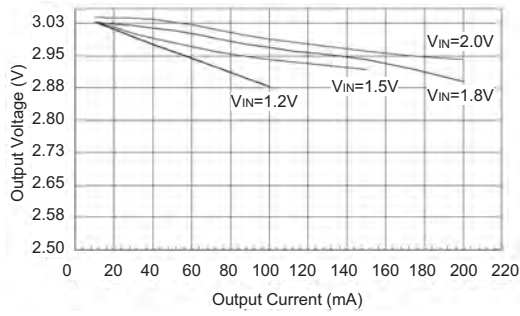

HK77XXA Output Voltage vs Output Current

( $C_{IN}=47\mu\text{F-Tantalum}$ ,  $L=47\mu\text{H}$ ,  $C_{OUT}=22\mu\text{F-Tantalum}$ )

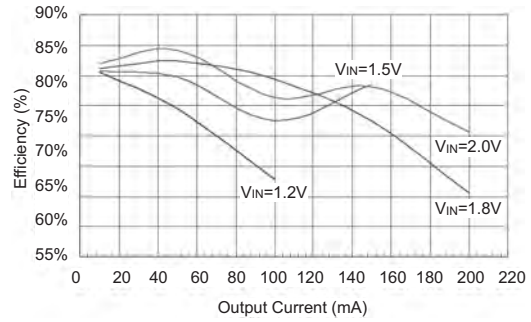

HK77XXA Efficiency vs Output Current

( $C_{IN}=47\mu\text{F-Tantalum}$ ,  $L=47\mu\text{H}$ ,  $C_{OUT}=22\mu\text{F-Tantalum}$ )

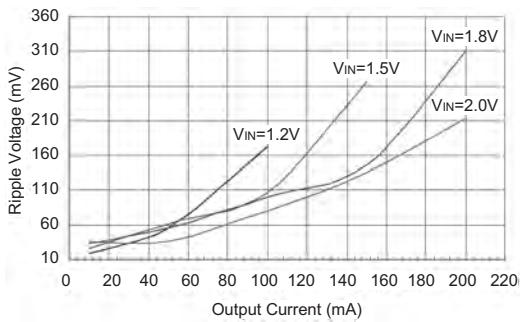

HK77XXA Ripple Voltage vs Output Current

( $C_{IN}=47\mu\text{F-Tantalum}$ ,  $L=47\mu\text{H}$ ,  $C_{OUT}=22\mu\text{F-Tantalum}$ )

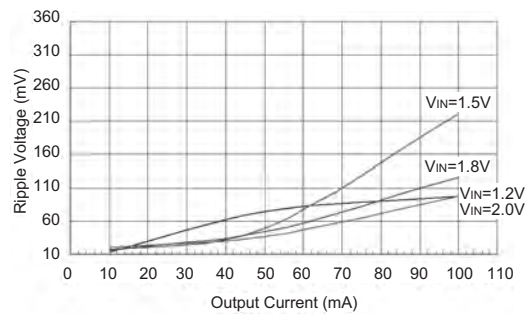

HK77XXA Ripple Voltage vs Output Current

( $C_{IN}=47\mu\text{F-Tantalum}$ ,  $L=100\mu\text{H}$ ,  $C_{OUT}=22\mu\text{F-Tantalum}$ )

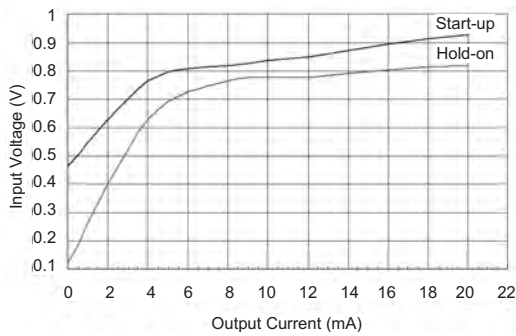

HK77XXA Start-up/ Hold-on Voltage

( $C_{IN}=47\mu\text{F-Tantalum}$ ,  $L=47\mu\text{H}$ ,  $C_{OUT}=22\mu\text{F-Tantalum}$ )

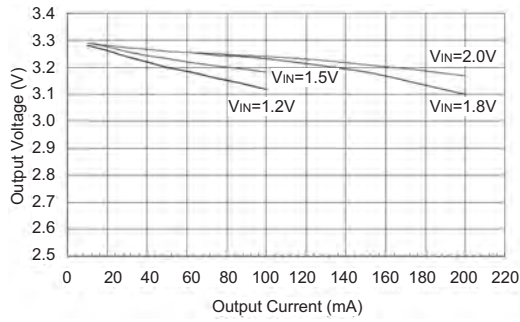

HK77XXA OutputVoltage.v.sOutputCurrent

( $C_{IN}=47\mu\text{F-Tantalum}$ ,  $L=47\mu\text{H}$ ,  $C_{OUT}=22\mu\text{F-Tantalum}$ )

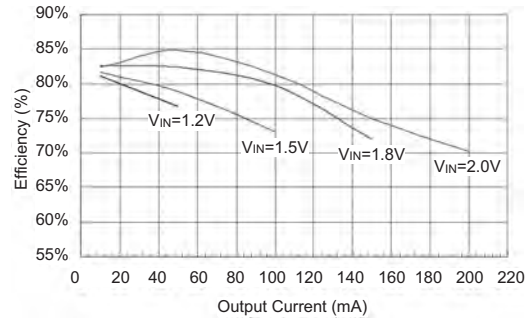

HK77XXA Efficiency.v.sOutputCurrent

( $C_{IN}=47\mu\text{F-Tantalum}$ ,  $L=47\mu\text{H}$ ,  $C_{OUT}=22\mu\text{F-Tantalum}$ )

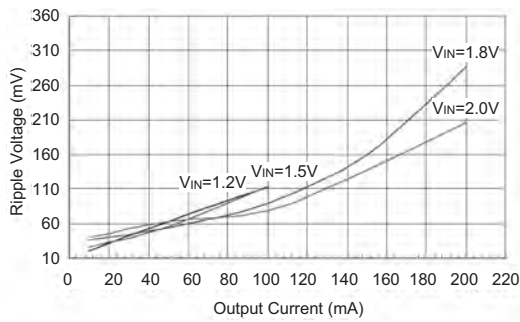

HK77XXA RippleVoltage.v.sOutputCurrent

( $C_{IN}=47\mu\text{F-Tantalum}$ ,  $L=47\mu\text{H}$ ,  $C_{OUT}=22\mu\text{F-Tantalum}$ )

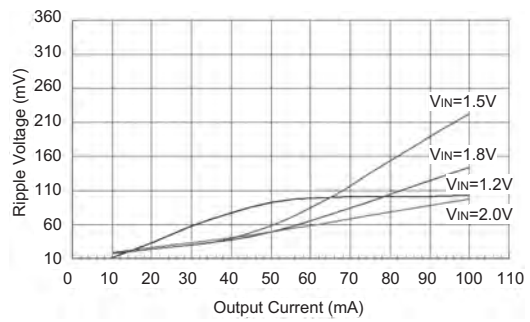

HK77XXA RippleVoltage.v.sOutputCurrent

( $C_{IN}=47\mu\text{F-Tantalum}$ ,  $L=100\mu\text{H}$ ,  $C_{OUT}=22\mu\text{F-Tantalum}$ )

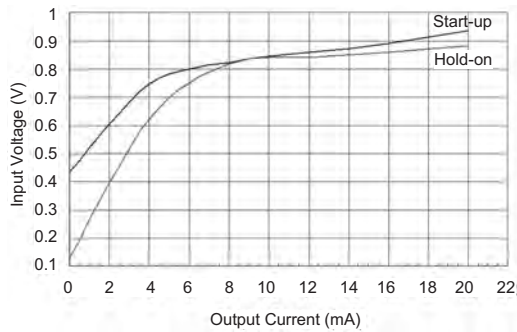

HK77XXA Start-up/Hold-onVoltage

( $C_{IN}=47\mu\text{F-Tantalum}$ ,  $L=47\mu\text{H}$ ,  $C_{OUT}=22\mu\text{F-Tantalum}$ )

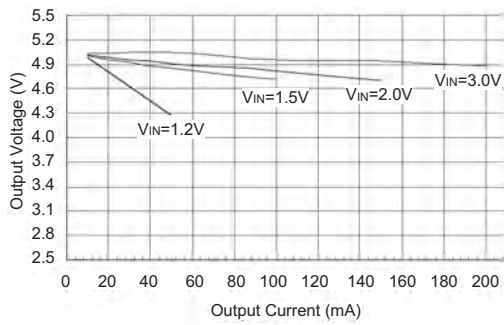

HK77XXA Output Voltage vs Output Current

( $C_{IN}=47\mu\text{F-Tantalum}$ ,  $L=47\mu\text{H}$ ,  $C_{OUT}=22\mu\text{F-Tantalum}$ )

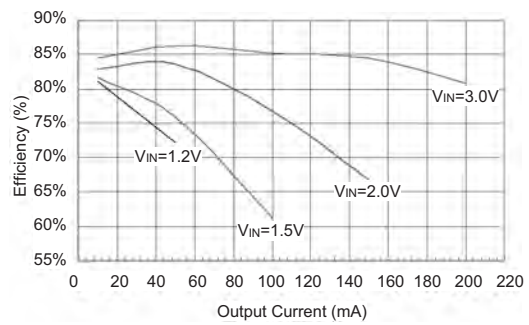

HK77XXA Efficiency vs Output Current

( $C_{IN}=47\mu\text{F-Tantalum}$ ,  $L=47\mu\text{H}$ ,  $C_{OUT}=22\mu\text{F-Tantalum}$ )

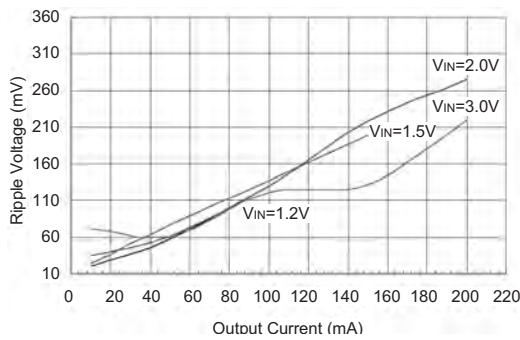

HK77XXA Ripple Voltage vs Output Current

( $C_{IN}=47\mu\text{F-Tantalum}$ ,  $L=47\mu\text{H}$ ,  $C_{OUT}=22\mu\text{F-Tantalum}$ )

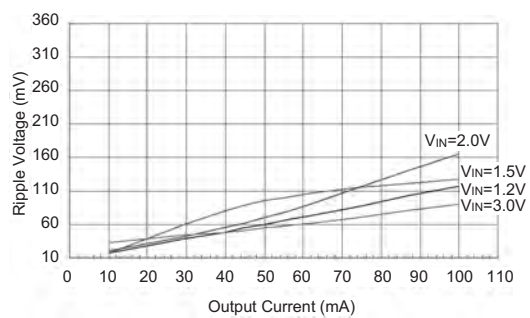

HK77XXA Ripple Voltage vs Output Current

( $C_{IN}=47\mu\text{F-Tantalum}$ ,  $L=100\mu\text{H}$ ,  $C_{OUT}=22\mu\text{F-Tantalum}$ )

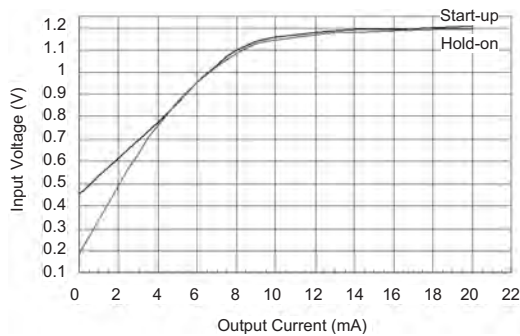

HK77XXA Start-up/hold-on Voltage

( $C_{IN}=47\mu\text{F-Tantalum}$ ,  $L=47\mu\text{H}$ ,  $C_{OUT}=22\mu\text{F-Tantalum}$ )



## Application Circuits

### Without CE Pin

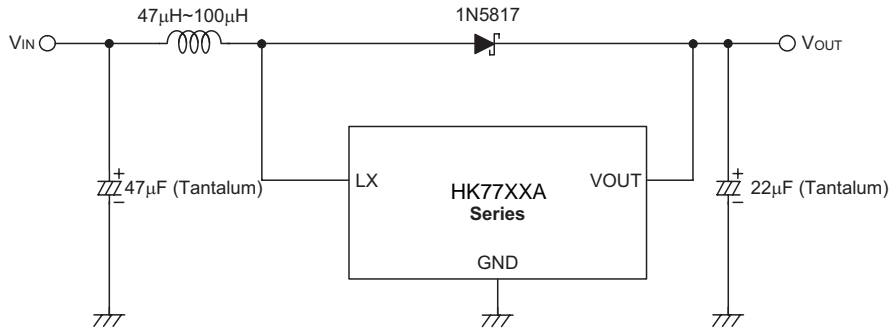

### With CE Pin

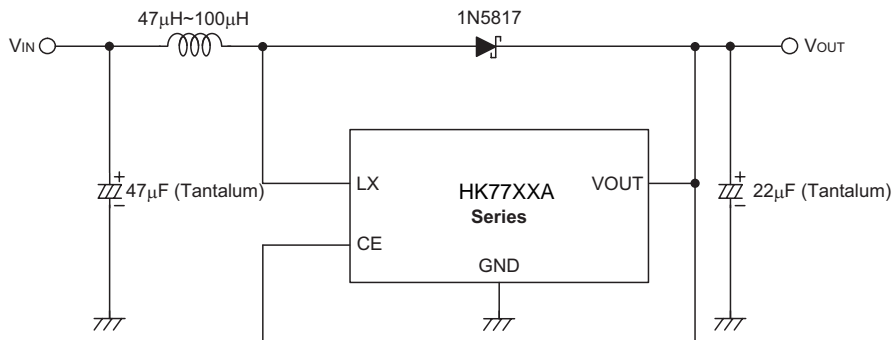
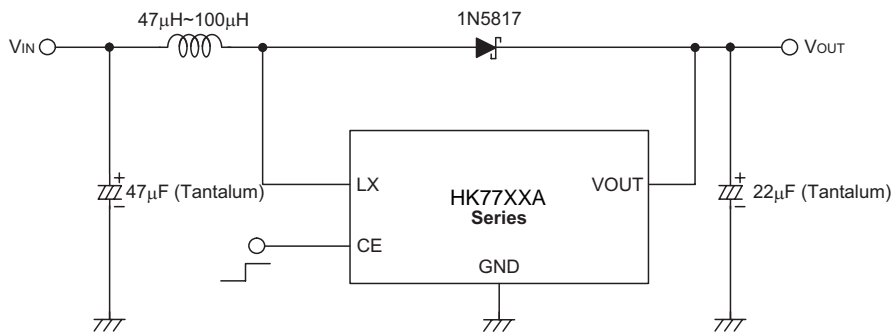

Note: For the SOT-25 package, when CE is pulled low, the internal blocks of the device, such as the reference band gap, gain block, and all feedback and control circuitry will be switched off. The boost converter's output,  $V_{OUT}$ , will be at a value one Schottky diode voltage drop below the input voltage and the LX pin remains in a high impedance condition. The output capacitor and load at  $V_{OUT}$  determine the rate at which  $V_{OUT}$  decays.



Package Information

3-pin TO-92 Outline Dimensions

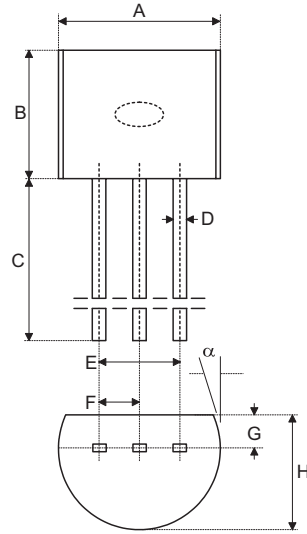

Symbol	Dimensions in mil		
	Min.	Nom.	Max.
A	170	—	200
B	170	—	200
C	500	—	—
D	11	—	20
E	90	—	110
F	45	—	55
G	45	—	65
H	130	—	160
I	8	—	18
$\alpha$	4°	—	6°

3-pin SOT-89 Outline Dimensions

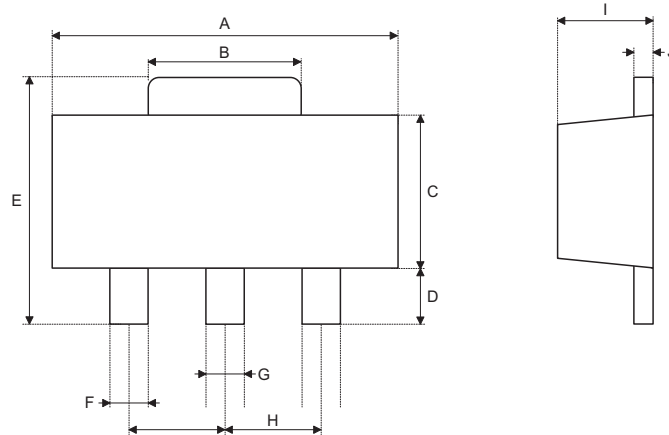

Symbol	Dimensions in mil		
	Min.	Nom.	Max.
A	173	—	181
B	64	—	72
C	90	—	102
D	35	—	47
E	155	—	167
F	14	—	19
G	17	—	22
H	—	59	—
I	55	—	63
J	14	—	17

3-pin SOT-23 Outline Dimensions

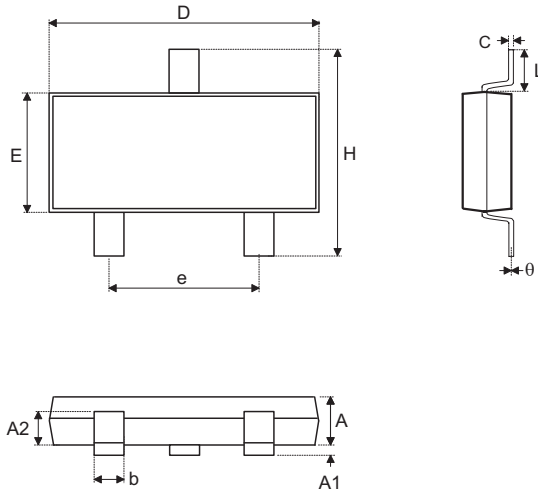

Symbol	Dimensions in mm		
	Min.	Nom.	Max.
A	1	—	1.3
A1	—	—	0.1
A2	0.7	—	0.9
b	0.35	—	0.5
C	0.1	—	0.25
D	2.7	—	3.1
E	1.4	—	1.8
e	—	1.9	—
H	2.6	—	3
L	0.37	—	—
θ	1°	—	9°

5-pin SOT-25 Outline Dimensions

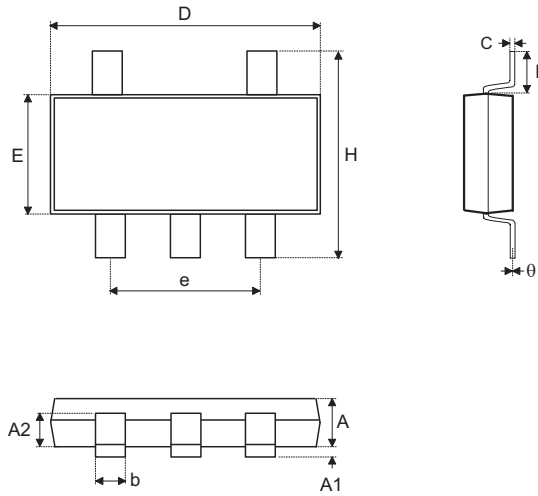

Symbol	Dimensions in mm		
	Min.	Nom.	Max.
A	1.00	—	1.30
A1	—	—	0.10
A2	0.70	—	0.90
b	0.35	—	0.50
C	0.10	—	0.25
D	2.70	—	3.10
E	1.40	—	1.80
e	—	1.90	—
H	2.60	—	3
L	0.37	—	—
θ	1°	—	9°

Product Tape and Reel Specifications

TO-92 Reel Dimensions (Unit: mm)

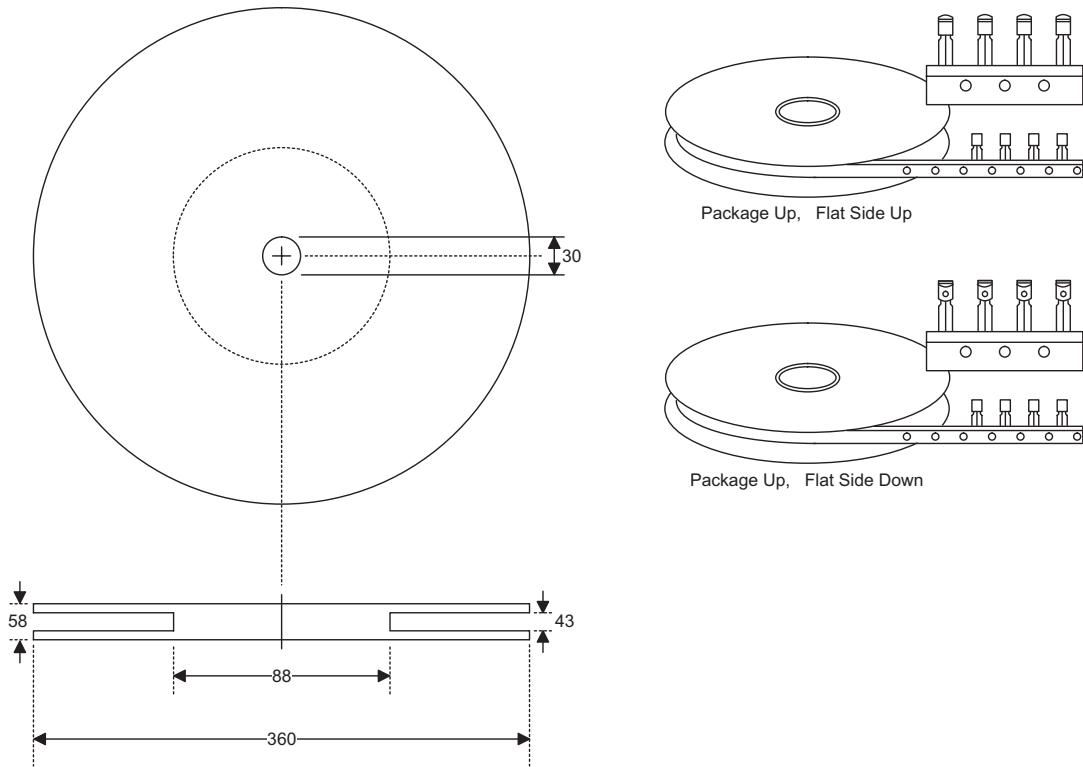

SOT-89, SOT-23 & SOT-25 Reel Dimensions

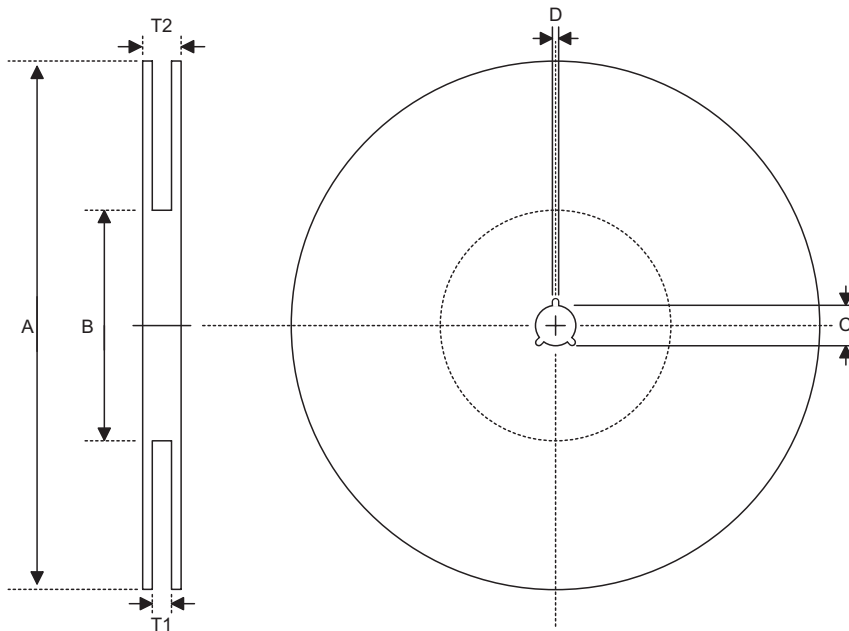

SOT-89

Symbol	Description	Dimensions in mm
A	Reel Outer Diameter	180±1.0
B	Reel Inner Diameter	62±1.5
C	Spindle Hole Diameter	12.75+0.15
D	Key Slit Width	1.9±0.15
T1	Space Between Flange	12.4+0.2
T2	Reel Thickness	17-0.4

SOT-23

Symbol	Description	Dimensions in mm
A	Reel Outer Diameter	178±1
B	Reel Inner Diameter	62±1
C	Spindle Hole Diameter	13±0.2
D	Key Slit Width	2.5±0.25
T1	Space Between Flange	8.4+1.5
T2	Reel Thickness	11.4+1.5

SOT-25

Symbol	Description	Dimensions in mm
A	Reel Outer Diameter	178±1.0
B	Reel Inner Diameter	62±1.0
C	Spindle Hole Diameter	13.0±0.2
D	Key Slit Width	2.5±0.25
T1	Space Between Flange	8.4+1.5 -0.0
T2	Reel Thickness	11.4+1.5

TO-92 Carrier Tape Dimensions

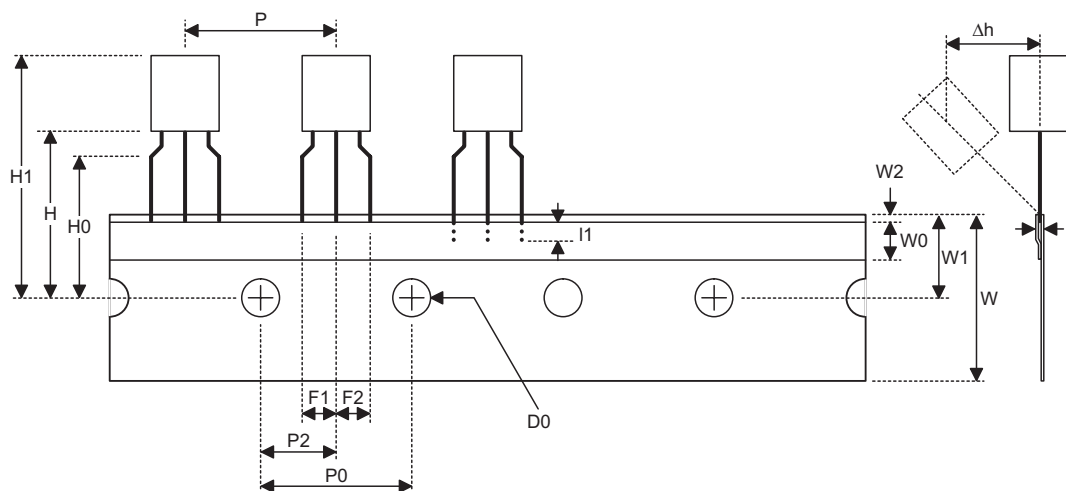

TO-92

Symbol	Description	Dimensions in mm
l1	Taped Lead Length	(2.5)
P	Component Pitch	12.7±1.0
P <sub>0</sub>	Perforation Pitch	12.7±0.3
P <sub>2</sub>	Component to Perforation (Length Direction)	6.35±0.4
F <sub>1</sub>	Lead Spread	2.5+0.4 -0.1
F <sub>2</sub>	Lead Spread	2.5+0.4 -0.1
Δh	Component Alignment	0±0.1
W	Carrier Tape Width	18.0+1.0 -0.5
W <sub>0</sub>	Hold-down Tape Width	6.0±0.5
W <sub>1</sub>	Perforation Position	9.0±0.5
W <sub>2</sub>	Hold-down Tape Position	(0.5)
H <sub>0</sub>	Lead Clinch Height	16.0±0.5
H <sub>1</sub>	Component Height	Less than 24.7
D <sub>0</sub>	Perforation Diameter	4.0±0.2
t	Taped Lead Thickness	0.7±0.2
H	Component Base Height	19.0±0.5

Note: Thickness less than 0.38±0.05mm~0.5mm  
 P<sub>0</sub> Accumulated pitch tolerance: ±1mm/20pitches.  
 ( ) Bracketed figures are for reference only.



SOT-89, SOT-23 & SOT-25 Carrier Tape Dimensions

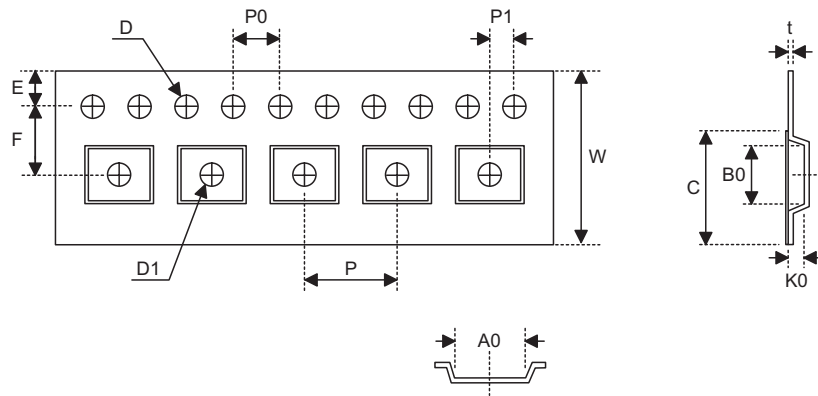

SOT-89

Symbol	Description	Dimensions in mm
W	Carrier Tape Width	12.0+0.3 -0.1
P	Cavity Pitch	8.0±0.1
E	Perforation Position	1.75±0.1
F	Cavity to Perforation (Width Direction)	5.5±0.05
D	Perforation Diameter	1.5+0.1
D1	Cavity Hole Diameter	1.5+0.1
P0	Perforation Pitch	4.0±0.1
P1	Cavity to Perforation (Length Direction)	2.0±0.10
A0	Cavity Length	4.8±0.1
B0	Cavity Width	4.5±0.1
K0	Cavity Depth	1.8±0.1
t	Carrier Tape Thickness	0.30±0.013
C	Cover Tape Width	9.3

SOT-23

Symbol	Description	Dimensions in mm
W	Carrier Tape Width	8±0.3
P	Cavity Pitch	4
E	Perforation Position	1.75
F	Cavity to Perforation (Width Direction)	3.5±0.05
D	Perforation Diameter	1.5+0.1
D1	Cavity Hole Diameter	1.5+0.1
P0	Perforation Pitch	4
P1	Cavity to Perforation (Length Direction)	2
A0	Cavity Length	3.15
B0	Cavity Width	3.2
K0	Cavity Depth	1.4
t	Carrier Tape Thickness	0.2±0.03
C	Cover Tape Width	5.3

SOT-25

Symbol	Description	Dimensions in mm
W	Carrier Tape Width	8.0±0.3
P	Cavity Pitch	4.0
E	Perforation Position	1.75
F	Cavity to Perforation (Width Direction)	3.5±0.05
D	Perforation Diameter	1.5+0.1
D1	Cavity Hole Diameter	1.5+0.1
P0	Perforation Pitch	4.0
P1	Cavity to Perforation (Length Direction)	2.0
A0	Cavity Length	3.15
B0	Cavity Width	3.2
K0	Cavity Depth	1.4
t	Carrier Tape Thickness	0.20±0.03
C	Cover Tape Width	5.3