



UT2035Z

Power MOSFET

-3.6A, -20V P-CHANNEL ENHANCEMENT MODE MOSFET

DESCRIPTION

The UTC **UT2035Z** is a P-channel enhancement mode MOSFET, it uses UTC's advanced technology to provide the customers with a minimum on state resistance, high switching speed and low gate charge, etc.

FEATURES

- * $R_{DS(ON)} < 42m\Omega$ @ $V_{GS} = -4.5V$, $I_D = -4.0A$
- $R_{DS(ON)} < 65m\Omega$ @ $V_{GS} = -2.5V$, $I_D = -4.0A$
- $R_{DS(ON)} < 82m\Omega$ @ $V_{GS} = -1.8V$, $I_D = -2.0A$
- * High switching speed
- * Low gate charge
- * Low gate threshold voltage
- * Low input capacitance
- * Low input/output leakage

SYMBOL

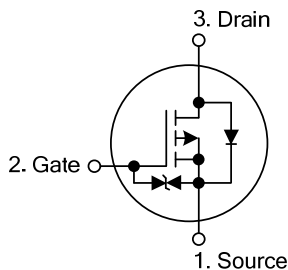

ORDERING INFORMATION

Ordering Number	Package	Pin Assignment			Packing
		1	2	3	
UT2035ZG-AE3-R	SOT-23	S	G	D	Tape Reel

Note: Pin Assignment: S: Source G: Gate D: Drain

	<p>(1) R: Tape Reel</p> <p>(2) AE3: SOT-23</p> <p>(3) G: Halogen Free and Lead Free</p>
--	---

MARKING

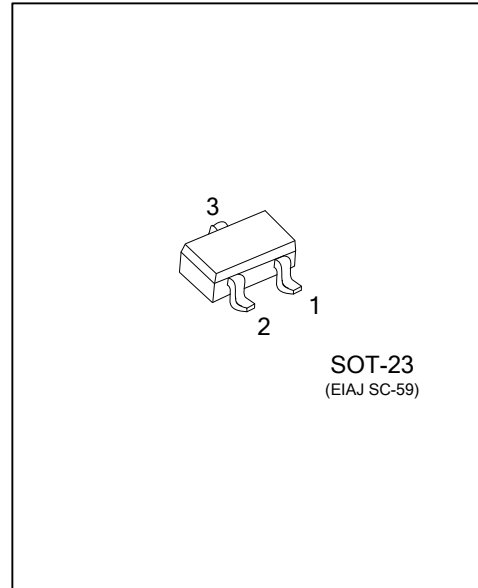
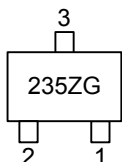

■ ABSOLUTE MAXIMUM RATINGS ($T_A=25^{\circ}\text{C}$, unless otherwise specified)

PARAMETER		SYMBOL	RATINGS	UNIT	
Drain-Source Voltage		V_{DSS}	-20	V	
Gate-Source Voltage		V_{GSS}	± 8	V	
Drain Current	Continuous (Note 2)	Steady, $T_A=25^{\circ}\text{C}$ State, $T_A=70^{\circ}\text{C}$	I_D	-3.6	A
				-2.9	A
	Pulsed (Note 3)		I_{DM}	-24	A
Power Dissipation (Note 2)		P_D	0.81	W	
Junction Temperature		T_J	-55~+150	$^{\circ}\text{C}$	
Storage Temperature Range		T_{STG}	-55~+150	$^{\circ}\text{C}$	

Notes: 1. Absolute maximum ratings are those values beyond which the device could be permanently damaged.

Absolute maximum ratings are stress ratings only and functional device operation is not implied.

2. Device mounted on FR-4 PCB with 2oz. Copper and test pulse width $t \leq 10\text{s}$.

3. Repetitive rating, pulse width limited by junction temperature.

■ THERMAL CHARACTERISTICS ($T_A=25^{\circ}\text{C}$, unless otherwise specified)

PARAMETER	SYMBOL	RATINGS	UNIT
Junction to Ambient	θ_{JA}	153.5	$^{\circ}\text{C}/\text{W}$

■ ELECTRICAL CHARACTERISTICS ($T_A=25^{\circ}\text{C}$, unless otherwise specified)

PARAMETER	SYMBOL	TEST CONDITIONS	MIN	TYP	MAX	UNIT
OFF CHARACTERISTICS (Note 1)						
Drain-Source Breakdown Voltage	BV_{DSS}	$I_D=-250\mu\text{A}$, $V_{GS}=0\text{V}$	-20			V
Drain-Source Leakage Current	I_{DSS}	$V_{DS}=-20\text{V}$, $V_{GS}=0\text{V}$			-1.0	μA
Gate-Source Leakage Current		Forward			+10	μA
		Reverse			-10	μA
ON CHARACTERISTICS (Note 1)						
Gate Threshold Voltage	$V_{GS(TH)}$	$V_{DS}=V_{GS}$, $I_D=-250\mu\text{A}$	-0.4	-0.7	-1.0	V
Static Drain-Source On-State Resistance	$R_{DS(ON)}$	$V_{GS}=-4.5\text{V}$, $I_D=-4.0\text{A}$		30	42	$\text{m}\Omega$
		$V_{GS}=-2.5\text{V}$, $I_D=-4.0\text{A}$		50	65	$\text{m}\Omega$
		$V_{GS}=-1.8\text{V}$, $I_D=-2.0\text{A}$		61	82	$\text{m}\Omega$
Forward Transfer Admittance	$ Y_{FS} $	$V_{DS}=-5\text{V}$, $I_D=-4\text{A}$		14		S
Diode Forward Voltage	V_{SD}	$V_{GS}=0\text{V}$, $I_S=-1\text{A}$		-0.7	-1.0	V
DYNAMIC PARAMETERS						
Input Capacitance	C_{ISS}	$V_{GS}=0\text{V}$, $V_{DS}=-10\text{V}$, $f=1.0\text{MHz}$		1610		pF
Output Capacitance	C_{OSS}			157		pF
Reverse Transfer Capacitance	C_{RSS}			145		pF
SWITCHING PARAMETERS						
Total Gate Charge	Q_G	$V_{GS}=-4.5\text{V}$, $V_{DS}=-10\text{V}$, $I_D=-4\text{A}$		15.4		nC
Gate to Source Charge	Q_{GS}			2.5		nC
Gate to Drain Charge	Q_{GD}			3.3		nC
Gate Resistance	R_G	$V_{DS}=0\text{V}$, $V_{GS}=0\text{V}$, $f=1\text{MHz}$		9.45		Ω
Turn-ON Delay Time	$t_{D(ON)}$	$V_{DS}=-10\text{V}$, $V_{GS}=-4.5\text{V}$, $I_D=-1\text{A}$, $R_G=6.0\Omega$, $R_L=10\Omega$		16.8		ns
Rise Time	t_R			12.4		ns
Turn-OFF Delay Time	$t_{D(OFF)}$			94.1		ns
Fall-Time	t_F			42.4		ns

Note: Short duration pulse test used to minimize self-heating effect.

TYPICAL CHARACTERISTICS

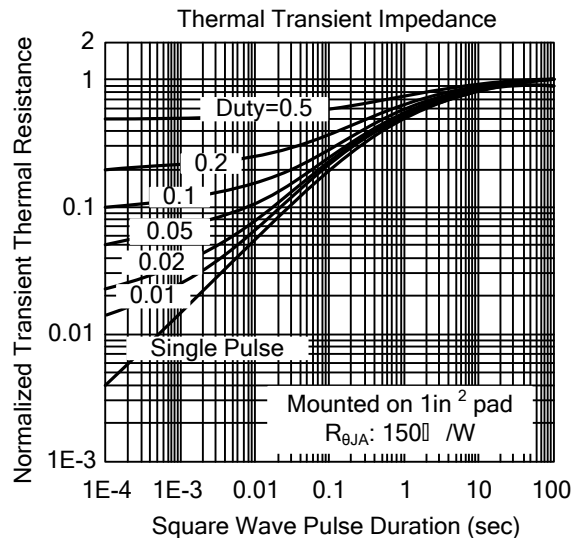
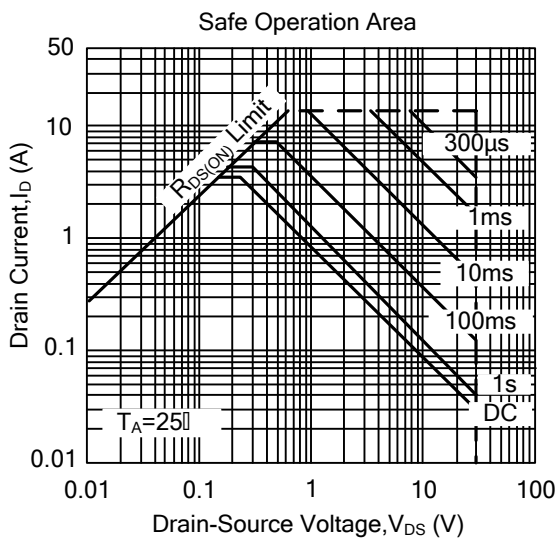
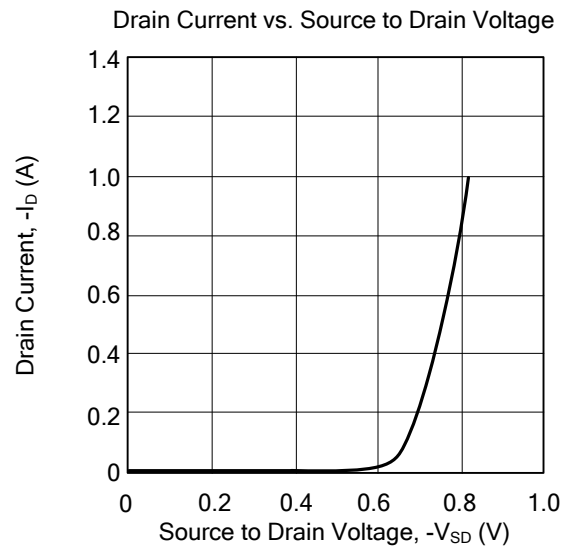
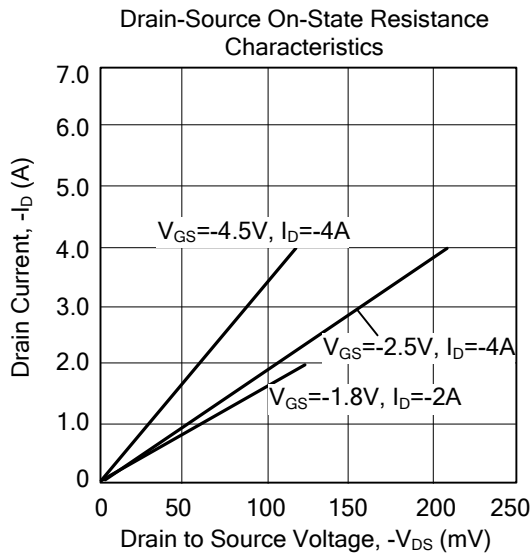
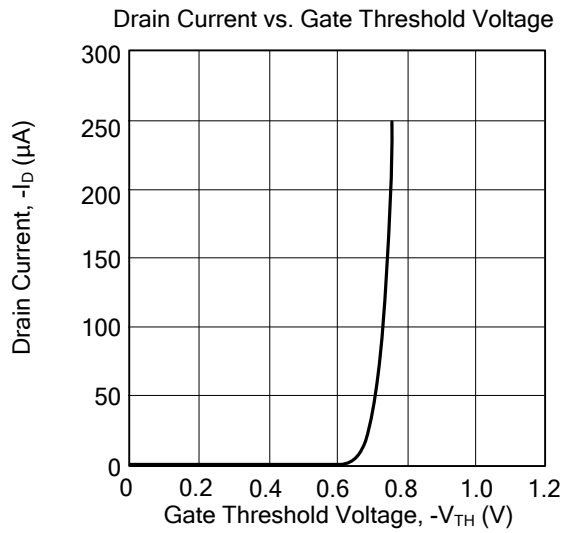
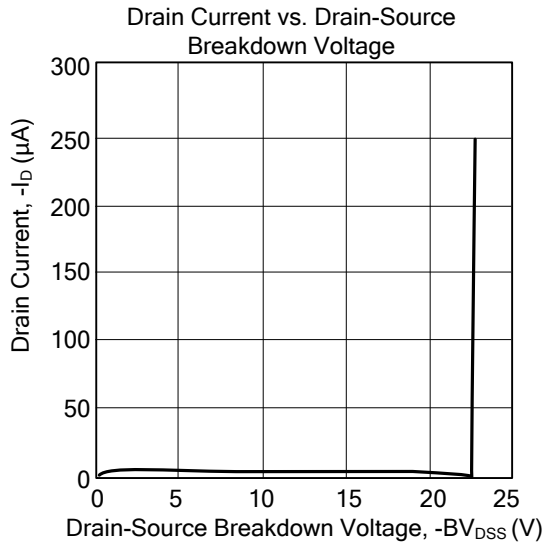

■ TYPICAL CHARACTERISTICS (Cont.)

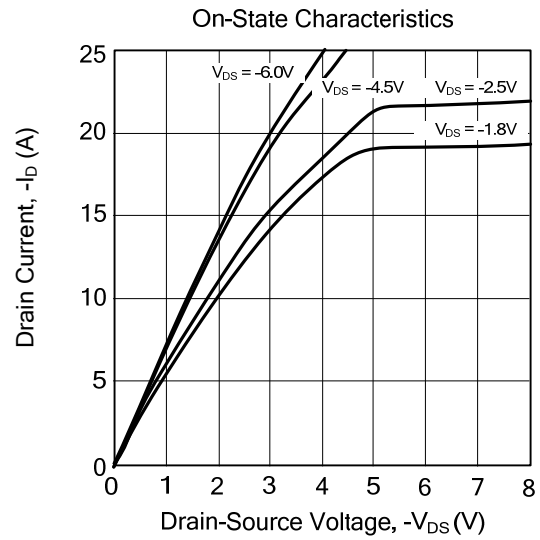
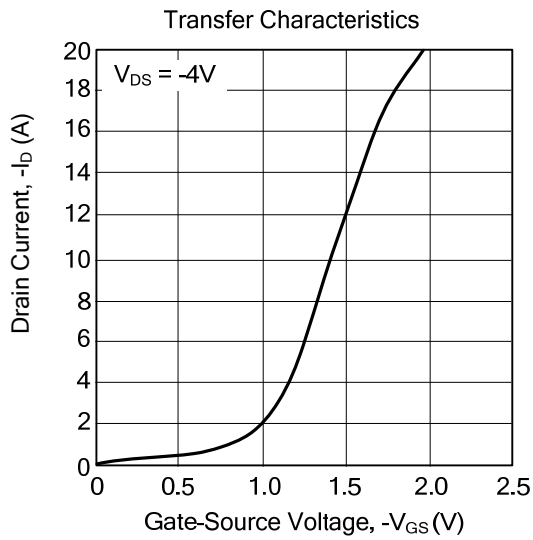

UTC assumes no responsibility for equipment failures that result from using products at values that exceed, even momentarily, rated values (such as maximum ratings, operating condition ranges, or other parameters) listed in products specifications of any and all UTC products described or contained herein. UTC products are not designed for use in life support appliances, devices or systems where malfunction of these products can be reasonably expected to result in personal injury. Reproduction in whole or in part is prohibited without the prior written consent of the copyright owner. The information presented in this document does not form part of any quotation or contract, is believed to be accurate and reliable and may be changed without notice.