



**UF601**

*Power MOSFET*

**0.185A, 600V N-CHANNEL DEPLETION-MODE POWER MOSFET**

■ DESCRIPTION

The UTC **UF601** is an N-channel power MOSFET using UTC's advanced technology to provide the customers with high switching speed.

■ FEATURES

- \*  $R_{DS(ON)} < 120\Omega @ V_{GS}=0V, I_D=3mA$
- \* High Switching Speed

■ SYMBOL

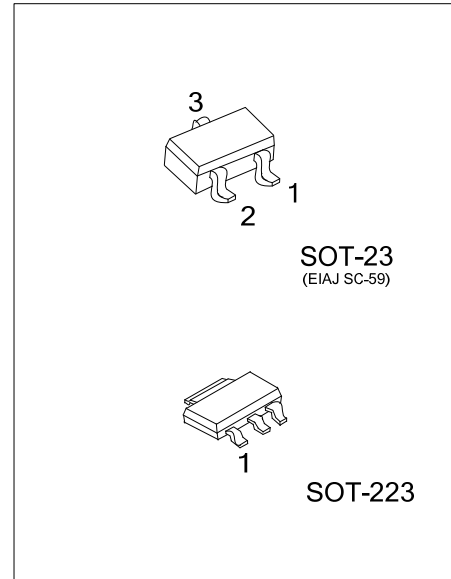
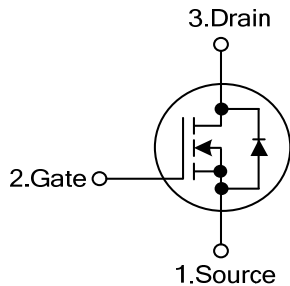

■ ORDERING INFORMATION

Ordering Number	Package	Pin Assignment			Packing
		1	2	3	
UF601G-AA3-R	SOT-223	S	G	D	Tape Reel
UF601G-AE3-R	SOT-23	S	G	D	Tape Reel

Note: Pin Assignment: G: Gate D: Drain S: Source

<p>UF601G-AA3-R</p> <p>(1)Packing Type</p> <p>(2)Package Type</p> <p>(3)Green Package</p>	<p>(1) R: Tape Reel</p> <p>(2) AA3: SOT-223, AE3: SOT-23</p> <p>(3) G: Halogen Free and Lead Free</p>
-------------------------------------------------------------------------------------------	-------------------------------------------------------------------------------------------------------

■ MARKING

SOT-223	SOT-23

■ ABSOLUTE MAXIMUM RATINGS (T<sub>A</sub>=25°C, unless otherwise specified)

PARAMETER		SYMBOL	RATINGS	UNIT
Drain-Source Voltage (Note 2)		V <sub>DSS</sub>	600	V
Drain-Gate Voltage (Note 2)		V <sub>DGX</sub>	600	V
Gate-Source Voltage		V <sub>GSS</sub>	±20	V
Drain Current	Continuous	I <sub>D</sub>	0.185	A
	Pulsed	I <sub>DM</sub>	0.740	A
Power Dissipation	SOT-223	P <sub>D</sub>	0.8	W
	SOT-23		0.5	W
Junction Temperature		T <sub>J</sub>	+150	°C
Storage Temperature		T <sub>STG</sub>	-55~+150	°C

Notes: 1. Absolute maximum ratings are those values beyond which the device could be permanently damaged.

Absolute maximum ratings are stress ratings only and functional device operation is not implied.

2. T<sub>J</sub>=+25°C~+150°C

■ THERMAL DATA

PARAMETER		SYMBOL	RATINGS	UNIT
Junction to Ambient	SOT-223	θ <sub>JA</sub>	150	°C/W
	SOT-23		250	°C/W

■ ELECTRICAL CHARACTERISTICS (T<sub>A</sub>=25°C, unless otherwise specified)

PARAMETER		SYMBOL	TEST CONDITIONS	MIN	TYP	MAX	UNIT	
<b>OFF CHARACTERISTICS</b>								
Drain-Source Breakdown Voltage		BV <sub>DSS</sub>	I <sub>D</sub> =250μA, V <sub>GS</sub> =-5V	600			V	
Drain-Source Leakage Current		I <sub>D(OFF)</sub>	V <sub>DS</sub> =600V, V <sub>GS</sub> =-5V			0.1	μA	
Gate-Source Leakage Current	Forward	I <sub>GSS</sub>	V <sub>GS</sub> =+20V, V <sub>DS</sub> =0V			+100	nA	
	Reverse		V <sub>GS</sub> =-20V, V <sub>DS</sub> =0V			-100	nA	
<b>ON CHARACTERISTICS</b>								
Gate to Source Cut Off Voltage		V <sub>GS(OFF)</sub>	V <sub>DS</sub> =3V, I <sub>D</sub> =8μA	-2.7		-1.5	V	
Drain-Source Leakage Current		I <sub>DSS</sub>	V <sub>DS</sub> =25V, V <sub>GS</sub> =0V	7.0			mA	
Static Drain-Source On-State Resistance		R <sub>DS(ON)</sub>	V <sub>GS</sub> =0V, I <sub>D</sub> =3mA		60	120	Ω	
<b>DYNAMIC PARAMETERS</b>								
Input Capacitance		C <sub>ISS</sub>	V <sub>GS</sub> =0V, V <sub>DS</sub> =25V, f=1.0MHz		53		pF	
Output Capacitance		C <sub>OSS</sub>				3000		pF
Reverse Transfer Capacitance		C <sub>RSS</sub>				2.6		pF
<b>SWITCHING PARAMETERS</b>								
Total Gate Charge		Q <sub>G</sub>	V <sub>GS</sub> =-5~5V, V <sub>DS</sub> =30V, I <sub>D</sub> =5mA		7.6		nC	
Gate to Source Charge		Q <sub>GS</sub>				4		nC
Gate to Drain Charge		Q <sub>GD</sub>				0.4		nC
Turn-ON Delay Time		t <sub>D(ON)</sub>	V <sub>GS</sub> =-5~5V, V <sub>DD</sub> =30V, I <sub>D</sub> =5mA, R <sub>G</sub> =20Ω		42		ns	
Rise Time		t <sub>R</sub>				20		ns
Turn-OFF Delay Time		t <sub>D(OFF)</sub>				80		ns
Fall-Time		t <sub>F</sub>				300		ns
<b>SOURCE- DRAIN DIODE RATINGS AND CHARACTERISTICS</b>								
Drain-Source Diode Forward Voltage		V <sub>SD</sub>	I <sub>SD</sub> =3.0mA, V <sub>GS</sub> =-10V			1.4	V	

Note: 1. Repetitive rating, pulse width limited by maximum junction temperature

2. Pulse width≤380μs; duty cycle≤2%

### TYPICAL CHARACTERISTICS

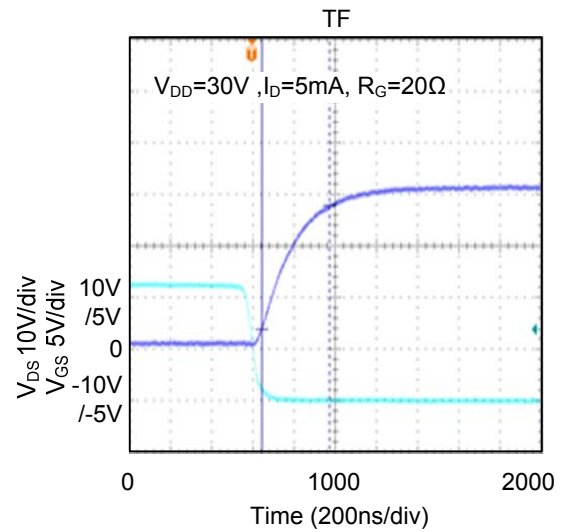
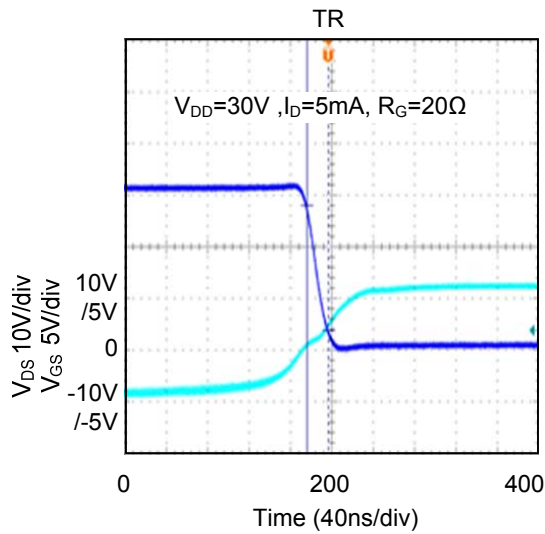

UTC assumes no responsibility for equipment failures that result from using products at values that exceed, even momentarily, rated values (such as maximum ratings, operating condition ranges, or other parameters) listed in products specifications of any and all UTC products described or contained herein. UTC products are not designed for use in life support appliances, devices or systems where malfunction of these products can be reasonably expected to result in personal injury. Reproduction in whole or in part is prohibited without the prior written consent of the copyright owner. The information presented in this document does not form part of any quotation or contract, is believed to be accurate and reliable and may be changed without notice.