



# UD606

*Power MOSFET*

## DUAL ENHANCEMENT MODE (N-CHANNEL/P-CHANNEL)

■ DESCRIPTION

The **UD606** can provide excellent  $R_{DS(ON)}$  and low gate charge by using advanced trench technology MOSFETs. The **UD606** may be used in H-bridge, inverters and other applications.

■ FEATURES

\* N-Channel: 40V/8A

$R_{DS(ON)} < 33m\Omega @ V_{GS} = 10V, I_D = 8A$

$R_{DS(ON)} < 55m\Omega @ V_{GS} = 4.5V, I_D = 6A$

\* P-Channel: -40V/-8A

$R_{DS(ON)} < 50m\Omega @ V_{GS} = -10V, I_D = -8A$

$R_{DS(ON)} < 70m\Omega @ V_{GS} = -4.5V, I_D = -4A$

\* Super high dense cell design

\* Reliable and rugged

■ SYMBOL

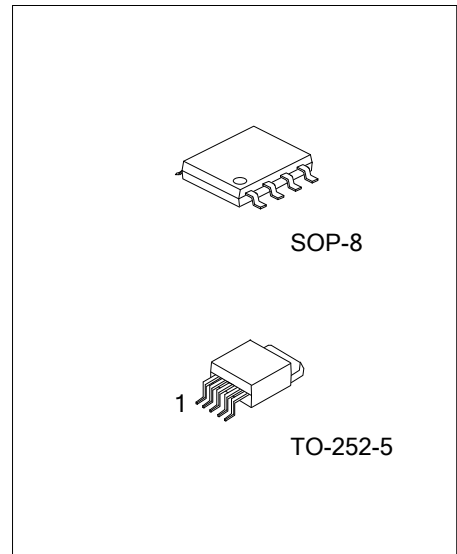
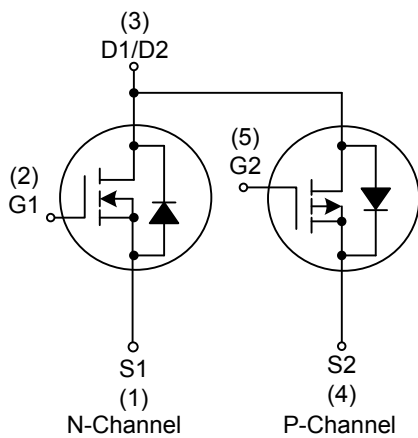

■ ORDERING INFORMATION

Ordering Number		Package	Pin Assignment								Packing
Lead Free	Halogen Free		1	2	3	4	5	6	7	8	
UD606L-TN5-R	UD606G-TN5-R	TO-252-5	S1	G1	D1/D2	S2	G2	-	-	-	Tape Reel
-	UD606G-S08-R	SOP-8	S1	G1	S2	G2	D2	D2	D1	D1	Tape Reel

<p>UD606L-TN5-R</p> <p>(1)Packing Type (2)Package Type (3)Green Package</p>	<p>(1) R: Tape Reel (2) TN5: TO-252-5, S08: SOP-8 (3) L: Lead Free, G: Halogen Free and Lead Free</p>
---	---

## MARKING

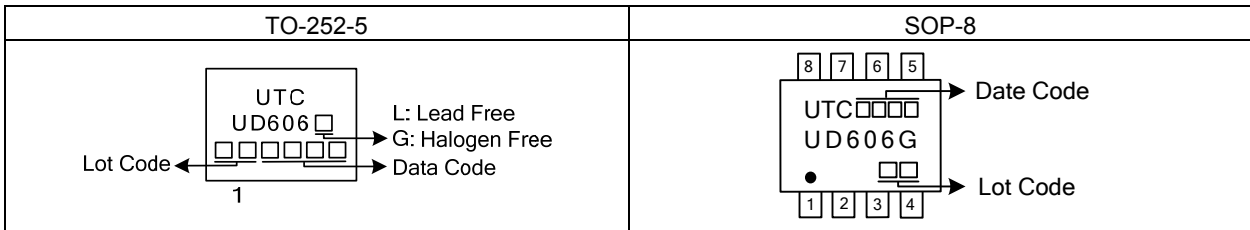

■ ABSOLUTE MAXIMUM RATINGS ( $T_A = 25^\circ\text{C}$ , unless otherwise specified)

**N-Channel:**

PARAMETER		SYMBOL	RATINGS	UNIT
Drain-Source Voltage		$V_{DSS}$	40	V
Gate-Source Voltage		$V_{GSS}$	$\pm 20$	V
Continuous Drain Current (Note3)	$T_C=25^\circ\text{C}$	$I_D$	8	A
Pulsed Drain Current (Note3)	$T_C=25^\circ\text{C}$	$I_{DM}$	30	A
Power Dissipation	TO-252-5	$P_D$	2	W
	SOP-8		1.25	W
Junction Temperature		$T_J$	+175	$^\circ\text{C}$
Storage Temperature		$T_{STG}$	-55 ~ +175	$^\circ\text{C}$

**P-Channel:**

PARAMETER		SYMBOL	RATINGS	UNIT
Drain-Source Voltage		$V_{DSS}$	-40	V
Gate-Source Voltage		$V_{GSS}$	$\pm 20$	V
Continuous Drain Current (Note3)	$T_C=25^\circ\text{C}$	$I_D$	-8	A
Pulsed Drain Current (Note3)	$T_C=25^\circ\text{C}$	$I_{DM}$	-30	A
Power Dissipation	TO-252-5	$P_D$	2	W
	SOP-8		1.25	W
Power Dissipation		$P_D$	2.5	W
Junction Temperature		$T_J$	+175	$^\circ\text{C}$
Storage Temperature		$T_{STG}$	-55 ~ +175	$^\circ\text{C}$

Note: Absolute maximum ratings are those values beyond which the device could be permanently damaged. Absolute maximum ratings are stress ratings only and functional device operation is not implied.

■ THERMAL DATA

PARAMETER			SYMBOL	MIN	TYP	MAX	UNIT
Junction to Ambient	N-Channel	TO-252-5	$\theta_{JA}$		50	60	$^\circ\text{C/W}$
		SOP-8			70	100	$^\circ\text{C/W}$
	P-Channel	TO-252-5			40	50	$^\circ\text{C/W}$
		SOP-8			68	100	$^\circ\text{C/W}$

■ ELECTRICAL CHARACTERISTICS (T<sub>A</sub>=25°C, unless otherwise specified)

**N-CHANNEL**

PARAMETER	SYMBOL	TEST CONDITIONS	MIN	TYP	MAX	UNIT
<b>OFF CHARACTERISTICS</b>						
Drain-Source Breakdown Voltage	BV <sub>DSS</sub>	V <sub>GS</sub> =0V, I <sub>D</sub> =250μA	40			V
Drain-Source Leakage Current	I <sub>DSS</sub>	V <sub>DS</sub> =32V, V <sub>GS</sub> =0V			1	μA
Gate-Source Leakage Current	I <sub>GSS</sub>	V <sub>DS</sub> =0V, V <sub>GS</sub> =±20V			±100	nA
<b>ON CHARACTERISTICS</b>						
Gate Threshold Voltage	V <sub>GS(TH)</sub>	V <sub>DS</sub> =V <sub>GS</sub> , I <sub>D</sub> =250μA	1	2.3	3	V
Drain-Source On-State Resistance (Note2)	R <sub>DS(ON)</sub>	V <sub>GS</sub> =10V, I <sub>D</sub> =8A			33	mΩ
		V <sub>GS</sub> =4.5V, I <sub>D</sub> =6A			55	mΩ
<b>DYNAMIC CHARACTERISTICS</b>						
Input Capacitance	C <sub>ISS</sub>	V <sub>GS</sub> =0V, V <sub>DS</sub> =20V, f=1MHz		580		pF
Output Capacitance	C <sub>OSS</sub>			100		pF
Reverse Transfer Capacitance	C <sub>RSS</sub>			87		pF
<b>SWITCHING CHARACTERISTICS</b>						
Turn-ON Delay Time (Note2)	t <sub>D(ON)</sub>	V <sub>DS</sub> =20V, V <sub>GS</sub> =10V, R <sub>G</sub> =3Ω I <sub>D</sub> =1A		30		ns
Turn-ON Rise Time	t <sub>R</sub>			30		ns
Turn-OFF Delay Time	t <sub>D(OFF)</sub>			140		ns
Turn-OFF Fall Time	t <sub>F</sub>			70		ns
Total Gate Charge (Note2)	Q <sub>G</sub>	V <sub>DS</sub> =20V, V <sub>GS</sub> =10V, I <sub>D</sub> =8A		85		nC
Gate-Source Charge	Q <sub>GS</sub>			9		nC
Gate-Drain Charge	Q <sub>GD</sub>			7		nC
<b>SOURCE- DRAIN DIODE RATINGS AND CHARACTERISTICS</b>						
Drain-Source Diode Forward Voltage(Note2)	V <sub>SD</sub>	I <sub>S</sub> =1A, V <sub>GS</sub> =0V		0.76	1	V
Diode Continuous Forward Current	I <sub>S</sub>				8	A
Reverse Recovery Time	t <sub>RR</sub>	I <sub>F</sub> =8A, di/dt=100A/μs		22.9		ns
Reverse Recovery Charge	Q <sub>RR</sub>				18.3	

■ ELECTRICAL CHARACTERISTICS(Cont.)

**P-CHANNEL**

PARAMETER	SYMBOL	TEST CONDITIONS	MIN	TYP	MAX	UNIT
<b>OFF CHARACTERISTICS</b>						
Drain-Source Breakdown Voltage	$BV_{DSS}$	$V_{GS}=0V, I_D=-250\mu A$	-40			V
Drain-Source Leakage Current	$I_{DSS}$	$V_{DS}=-32V, V_{GS}=0V$			-1	$\mu A$
Gate-Source Leakage Current	$I_{GSS}$	$V_{DS}=0V, V_{GS}=\pm 20V$			$\pm 100$	nA
<b>ON CHARACTERISTICS</b>						
Gate Threshold Voltage	$V_{GS(TH)}$	$V_{DS}=V_{GS}, I_D=-250\mu A$	-1	-1.8	-3	V
Drain-Source On-State Resistance (Note2)	$R_{DS(ON)}$	$V_{GS}=-10V, I_D=-8A$		35	50	$m\Omega$
		$V_{GS}=-4.5V, I_D=-4A$		55	70	$m\Omega$
<b>DYNAMIC CHARACTERISTICS</b>						
Input Capacitance	$C_{ISS}$	$V_{GS}=0V, V_{DS}=-20V, f=1.0MHz$		657		pF
Output Capacitance	$C_{OSS}$			143		pF
Reverse Transfer Capacitance	$C_{RSS}$			63		pF
<b>SWITCHING CHARACTERISTICS</b>						
Turn-ON Delay Time (Note2)	$t_{D(ON)}$	$V_{DS}=-20V, V_{GS}=-10V,$ $R_G=3\Omega, R_L=2.5\Omega$		8		ns
Turn-ON Rise Time	$t_R$			12.2		ns
Turn-OFF Delay Time	$t_{D(OFF)}$			24		ns
Turn-OFF Fall Time	$t_F$			12.5		ns
Total Gate Charge (Note2)	$Q_G$	$V_{DS}=-20V, V_{GS}=-10V, I_D=-8A$		14.1		nC
Gate-Source Charge	$Q_{GS}$			2.2		nC
Gate-Drain Charge	$Q_{GD}$			4.1		nC
<b>SOURCE- DRAIN DIODE RATINGS AND CHARACTERISTICS</b>						
Drain-Source Diode Forward Voltage(Note2)	$V_{SD}$	$I_S=-1A, V_{GS}=0V$		-0.75	-1	V
Diode Continuous Forward Current	$I_S$				-8	A
Reverse Recovery Time	$t_{RR}$	$I_F=-8A, dI/dt=100A/\mu s$		23.2		ns
Reverse Recovery Charge	$Q_{RR}$				18.2	

- Notes: 1. Pulse width limited by  $T_{J(MAX)}$   
 2. Pulse width  $\leq 300\mu s$ , duty cycle  $\leq 0.5\%$ .  
 3. Surface Mounted on  $1in^2$  pad area,  $t \leq 10sec$ .

## TYPICAL CHARACTERISTICS

### N-CHANNEL

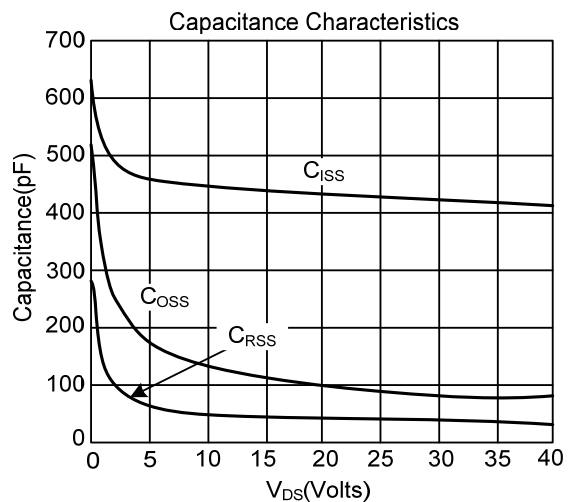
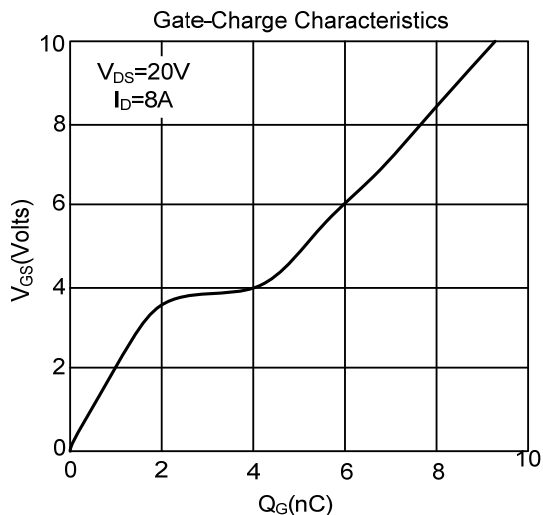
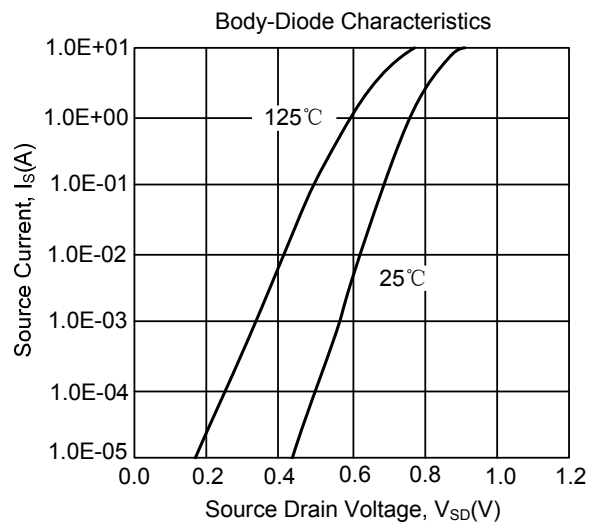
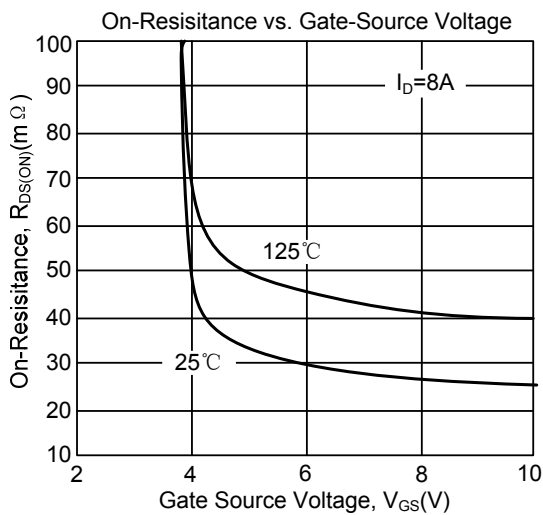
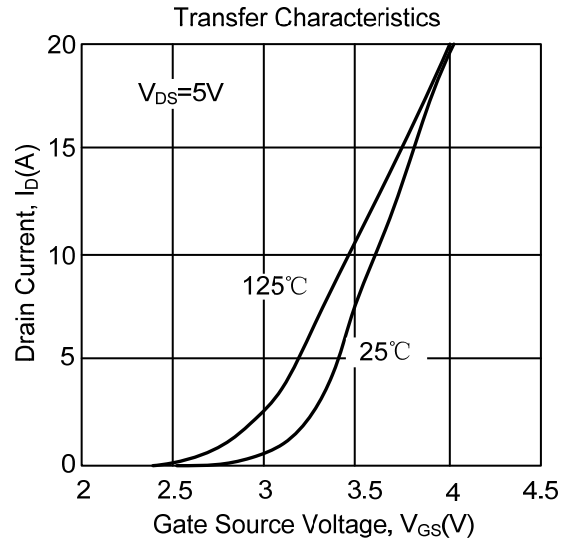
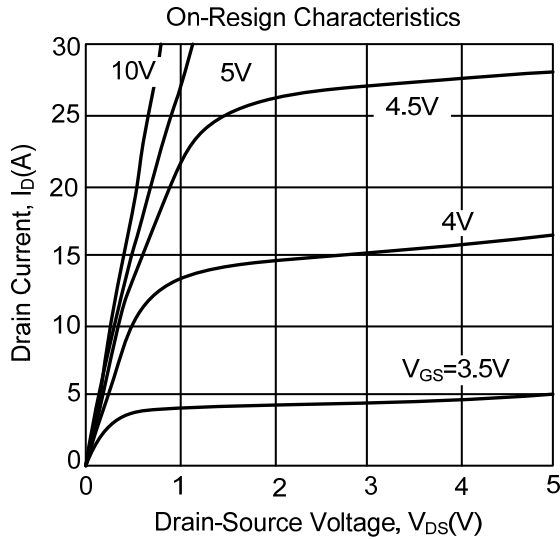

■ TYPICAL CHARACTERISTICS(Cont.)

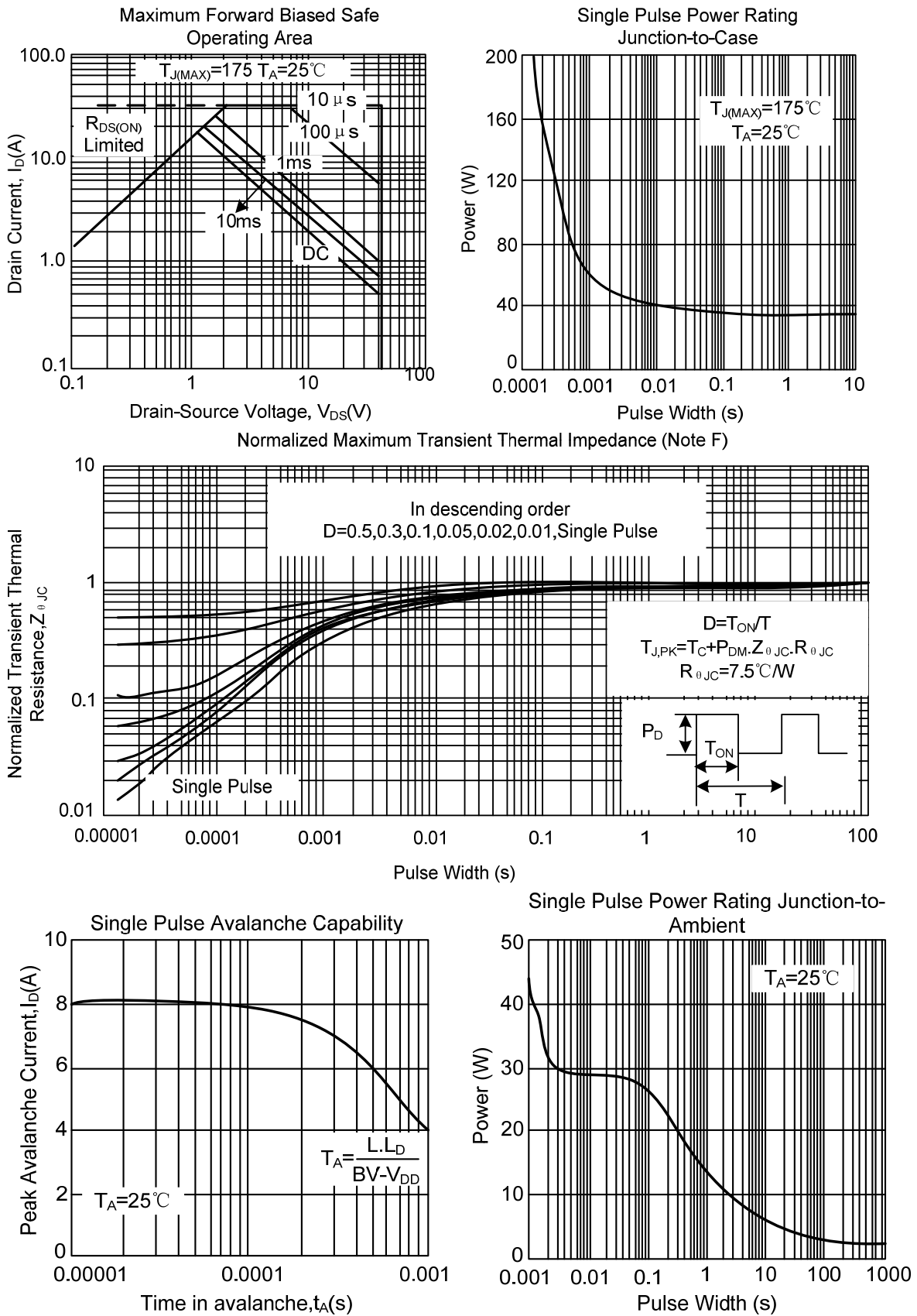

■ TYPICAL CHARACTERISTICS(Cont.)

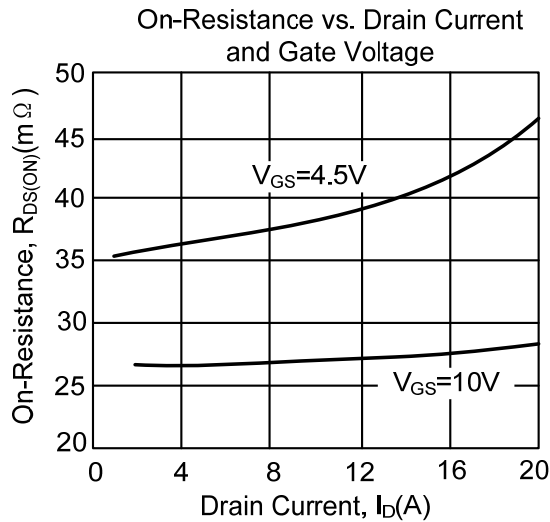
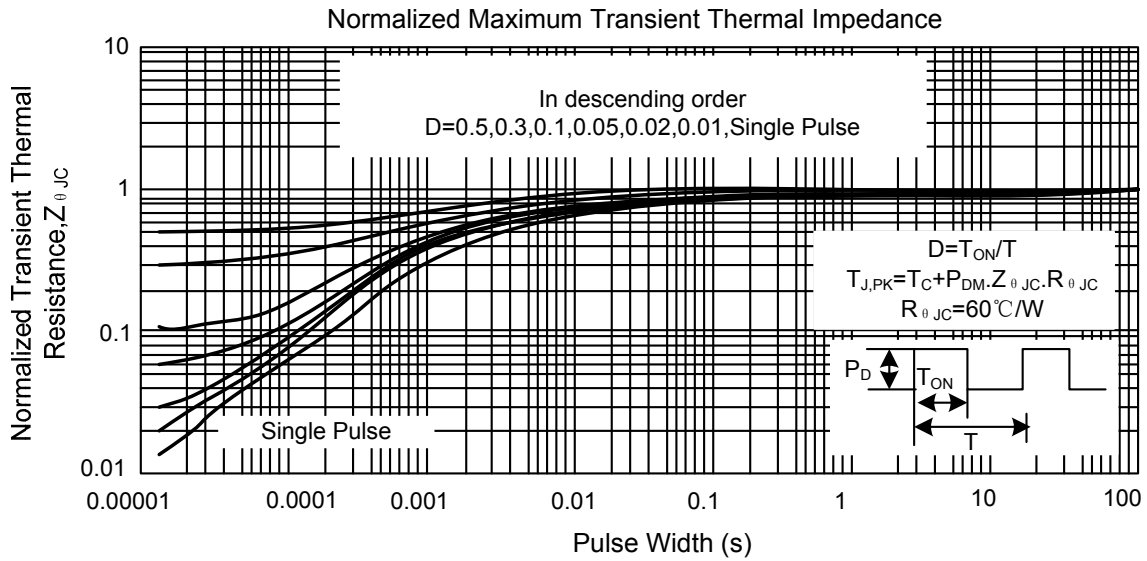



## ■ TYPICAL CHARACTERISTICS(Cont.)

### P-CHANNEL:

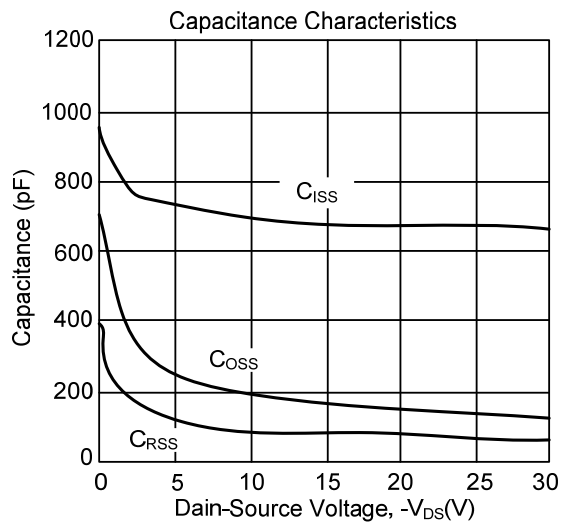
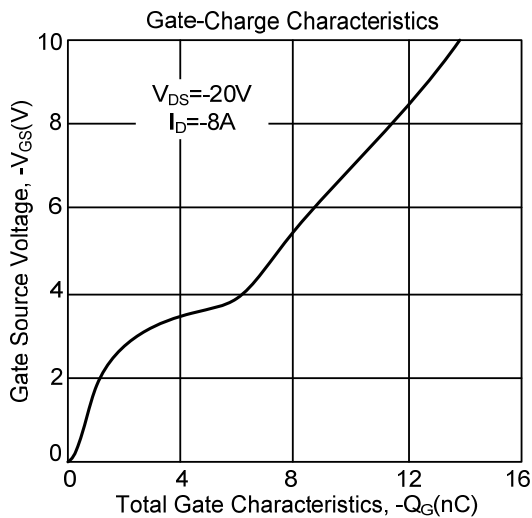
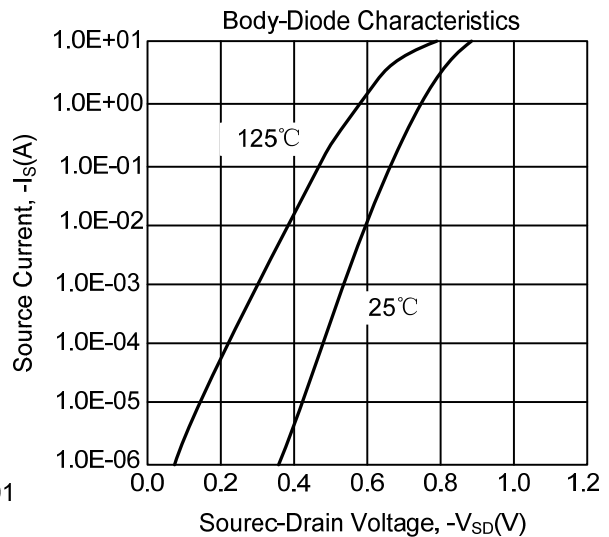
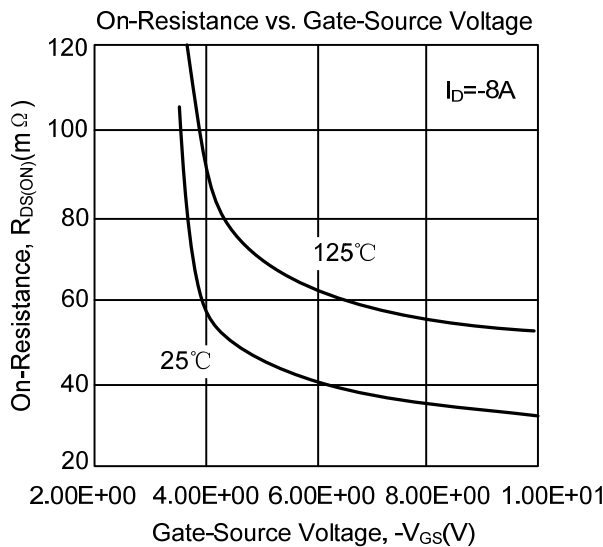
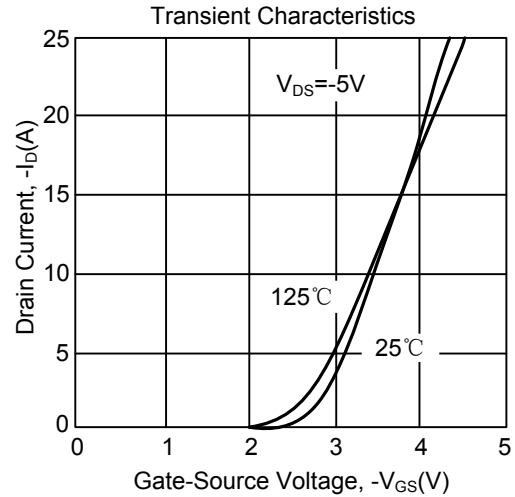
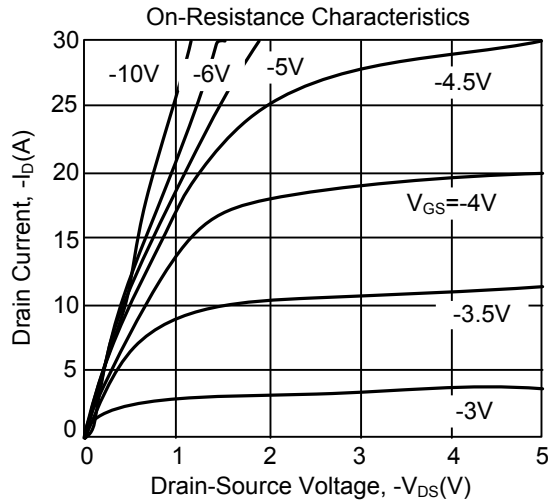

## TYPICAL CHARACTERISTICS(Cont.)

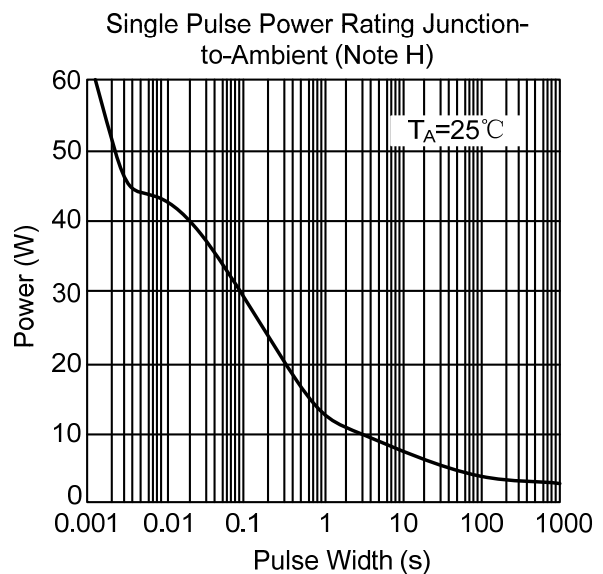
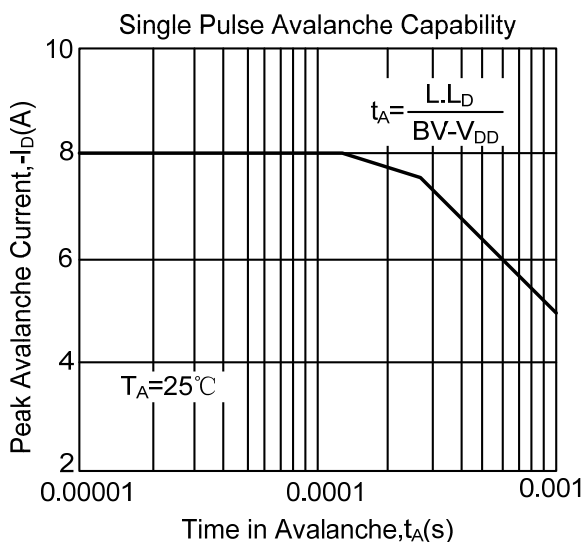
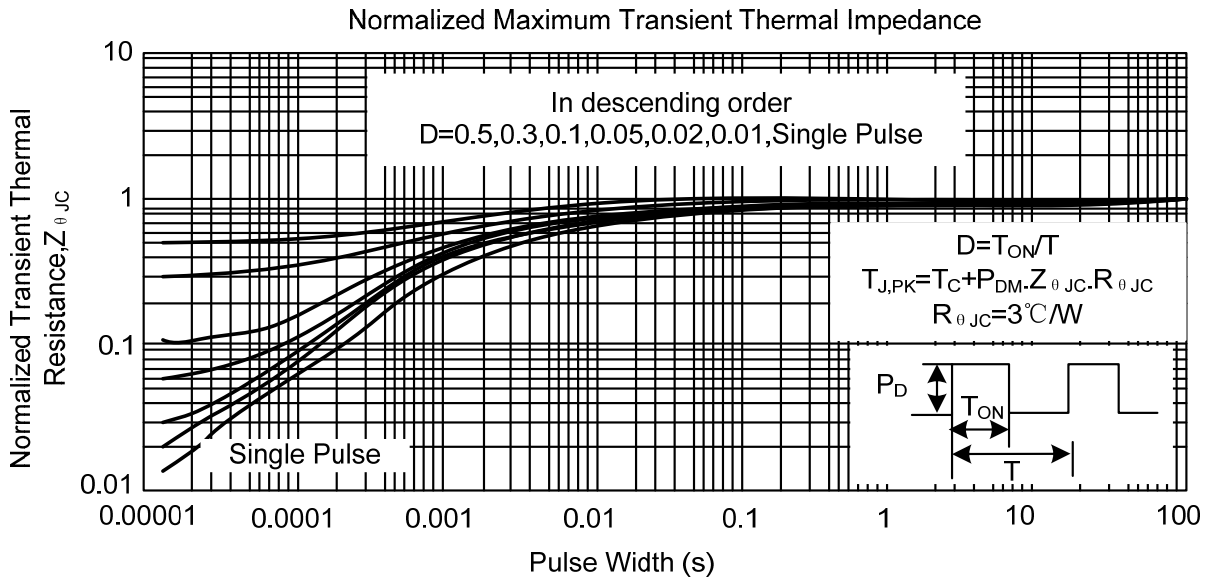
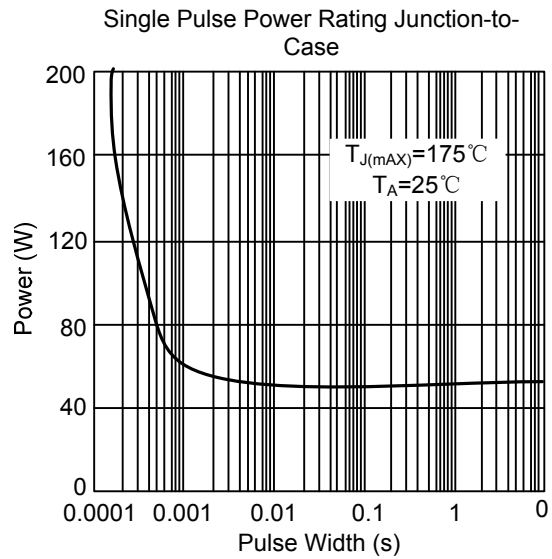
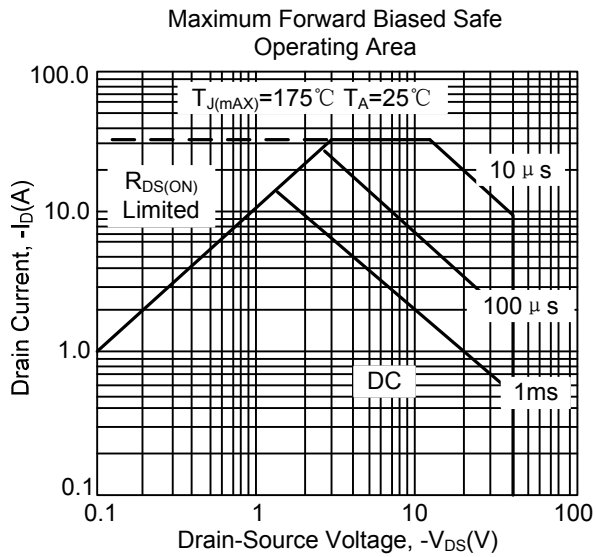

■ TYPICAL CHARACTERISTICS(Cont.)

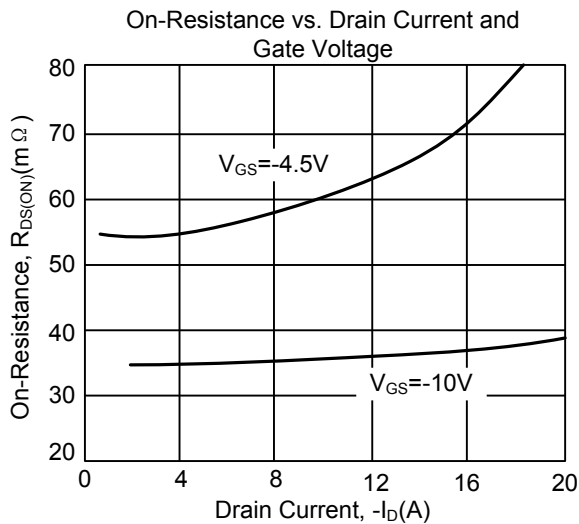
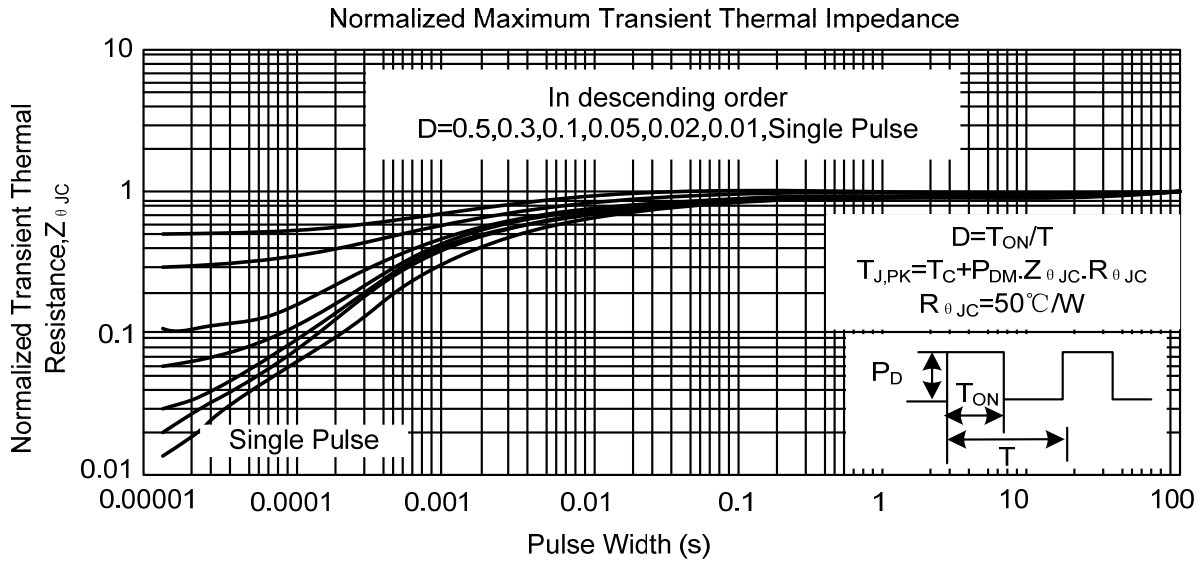

UTC assumes no responsibility for equipment failures that result from using products at values that exceed, even momentarily, rated values (such as maximum ratings, operating condition ranges, or other parameters) listed in products specifications of any and all UTC products described or contained herein. UTC products are not designed for use in life support appliances, devices or systems where malfunction of these products can be reasonably expected to result in personal injury. Reproduction in whole or in part is prohibited without the prior written consent of the copyright owner. The information presented in this document does not form part of any quotation or contract, is believed to be accurate and reliable and may be changed without notice.