



UTD408

Power MOSFET

N-CHANNEL ENHANCEMENT MODE

■ FEATURES

- * $R_{DS(ON)} = 18m\Omega @ V_{GS} = 10 V$
- * Low capacitance
- * Optimized gate charge
- * Fast switching capability
- * Avalanche energy specified

■ SYMBOL

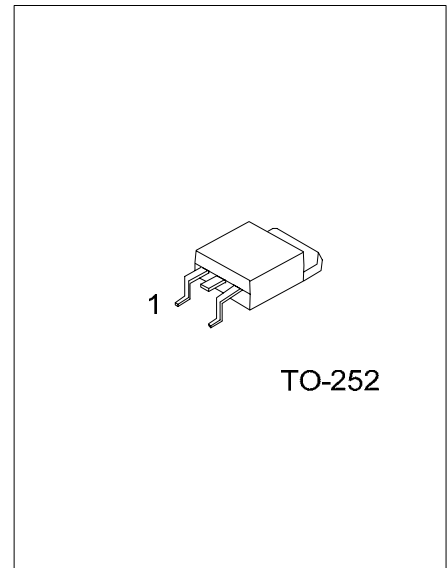
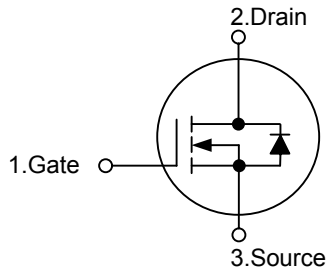

*Pb-free plating product number: UTD408L

■ ORDERING INFORMATION

Ordering Number		Package	Pin Assignment			Packing
Normal	Lead Free Plating		1	2	3	
UTD408-TN3-R	UTD408L-TN3-R	TO-252	G	D	S	Tape Reel
UTD408-TN3-T	UTD408L-TN3-T	TO-252	G	D	S	Tube

<p>UTD408L-TN3-R</p> <p>(1)Packing Type</p> <p>(2)Package Type</p> <p>(3)Lead Plating</p>	<p>(1) R: Tape Reel, T: Tube</p> <p>(2) TN3: TO-252</p> <p>(3) L: Lead Free Plating, Blank: Pb/Sn</p>
---	---

■ ABSOLUTE MAXIMUM RATINGS ($T_A = 25^\circ\text{C}$, unless otherwise specified)

PARAMETER	SYMBOL	RATINGS	UNIT
Drain-Source Voltage	V_{DSS}	30	V
Gate-Source Voltage	V_{GSS}	± 20	V
Continuous Drain Current ($T_C=25^\circ\text{C}$)	I_D	18	A
Pulsed Drain Current	I_{DM}	40	A
Avalanche Current	I_{AR}	18	A
Repetitive Avalanche Energy ($L=0.1\text{mH}$)	E_{AR}	40	mJ
Power Dissipation ($T_C=25^\circ\text{C}$)	P_D	60	W
Junction Temperature	T_J	+175	$^\circ\text{C}$
Strong Temperature	T_{STG}	-55 ~ +175	$^\circ\text{C}$

Note: Absolute maximum ratings are those values beyond which the device could be permanently damaged.

Absolute maximum ratings are stress ratings only and functional device operation is not implied.

■ THERMAL DATA

PARAMETER	SYMBOL	MIN	TYP	MAX	UNIT
Junction-to-Ambient	θ_{JA}		40	50	$^\circ\text{C/W}$

■ ELECTRICAL CHARACTERISTICS ($T_J = 25^\circ\text{C}$, unless otherwise specified)

PARAMETER	SYMBOL	TEST CONDITIONS	MIN	TYP	MAX	UNIT
OFF CHARACTERISTICS						
Drain-Source Breakdown Voltage	BV_{DSS}	$V_{GS} = 0\text{ V}, I_D = 250\mu\text{A}$	30			V
Drain-Source Leakage Current	I_{DSS}	$V_{DS} = 24\text{V}, V_{GS} = 0\text{ V}$			1	μA
Gate-Body Leakage Current	I_{GSS}	$V_{DS} = 0\text{ V}, V_{GS} = \pm 20\text{V}$			100	nA
ON CHARACTERISTICS						
Gate Threshold Voltage	$V_{GS(TH)}$	$V_{DS} = V_{GS}, I_D = 250\mu\text{A}$	1	1.8	2.5	V
On State Drain Current	$I_{D(ON)}$	$V_{DS} = 5\text{V}, V_{GS} = 4.5\text{V}$	40			A
Static Drain-Source On-Resistance	$R_{DS(ON)}$	$V_{GS} = 10\text{V}, I_D = 18\text{A}$		13.6	18	m Ω
		$V_{GS} = 4.5\text{V}, I_D = 10\text{A}$		20.6	27	m Ω
DYNAMIC PARAMETERS						
Input Capacitance	C_{ISS}	$V_{DS} = 15\text{ V}, V_{GS} = 0\text{V}, f = 1\text{MHz}$		1040	1250	pF
Output Capacitance	C_{OSS}			180		
Reverse Transfer Capacitance	C_{RSS}			110		
SWITCHING PARAMETERS						
Turn-ON Delay Time	$t_{D(ON)}$	$V_{GS} = 10\text{V}, V_{DS} = 15\text{V}, R_L = 0.82\Omega, R_{GEN} = 3\Omega$		4.5		ns
Turn-ON Rise Time	t_R			3.9		
Turn-OFF Delay Time	$t_{D(OFF)}$			17.4		
Turn-OFF Fall-Time	t_F			3.2		
Total Gate Charge	Q_G	$V_{DS} = 15\text{V}, V_{GS} = 10\text{V}, I_D = 18\text{A}$		19.8	25	nC
Gate Source Charge	Q_{GS}			2.5		
Gate Drain Charge	Q_{GD}			3.5		
SOURCE- DRAIN DIODE RATINGS AND CHARACTERISTICS						
Drain-Source Diode Forward Voltage	V_{SD}	$I_S = 1\text{A}, V_{GS} = 0\text{V}$		0.75	1	V
Maximum Continuous Drain-Source Diode Forward Current	I_S				18	A
Body Diode Reverse Recovery Time	t_{RR}	$I_F = 18\text{ A}, dI/dt = 100\text{A}/\mu\text{s}$		19	25	ns
Body Diode Reverse Recovery Charge	Q_{RR}	$I_F = 18\text{ A}, dI/dt = 100\text{A}/\mu\text{s}$		8		nC

Notes: 1. Pulse width limited by $T_{J(MAX)}$

2. Pulse width $\leq 300\mu\text{s}$, duty cycle $\leq 2\%$.

TYPICAL CHARACTERISTICS

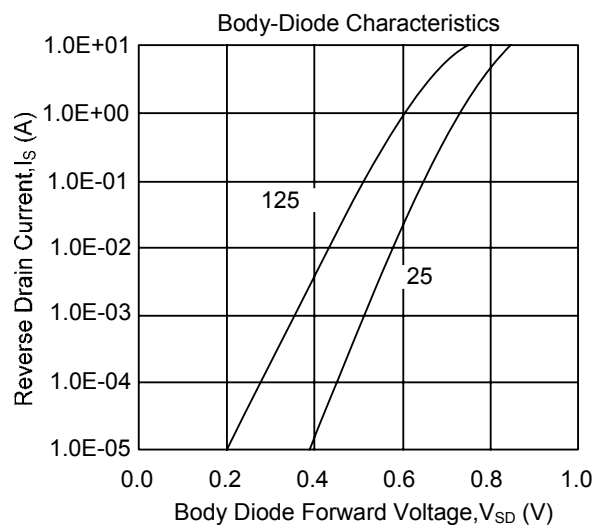
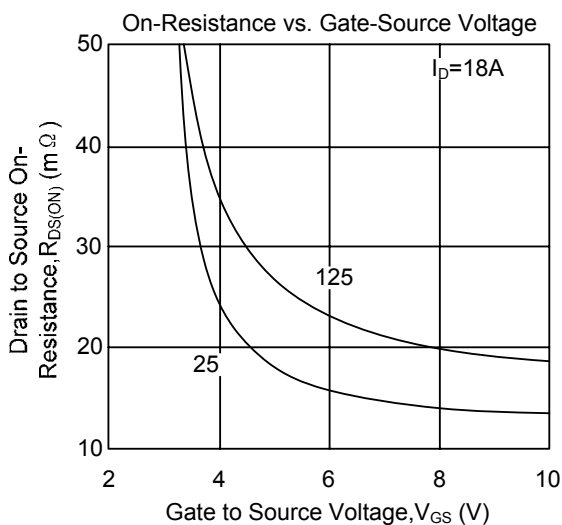
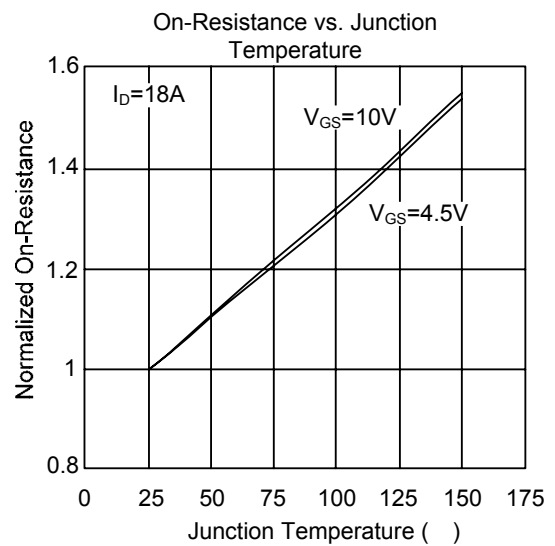
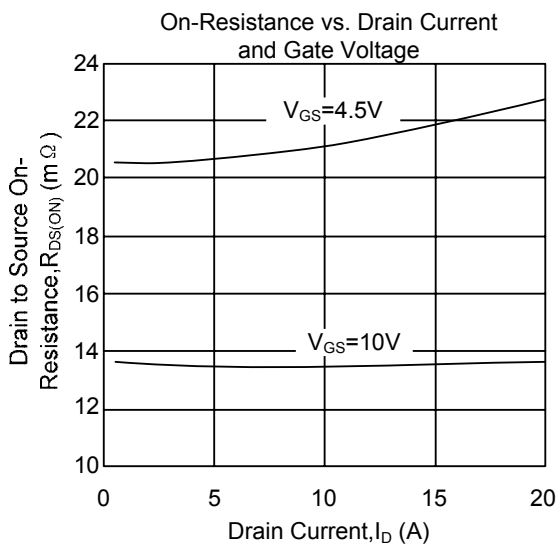
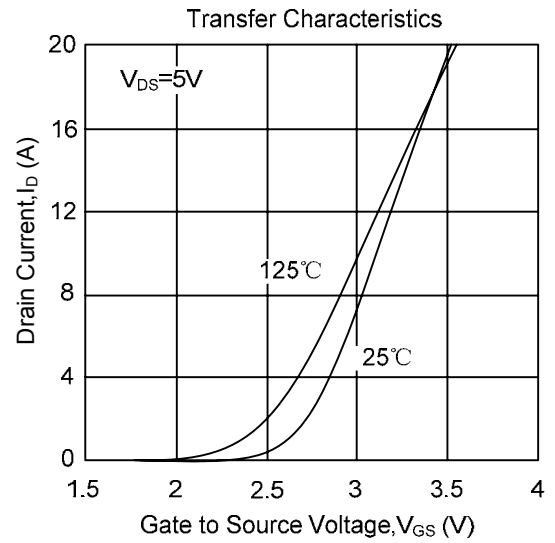
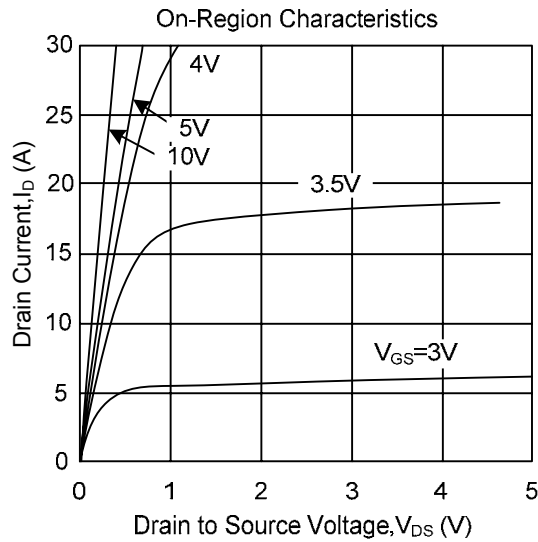

TYPICAL CHARACTERISTICS(Cont.)

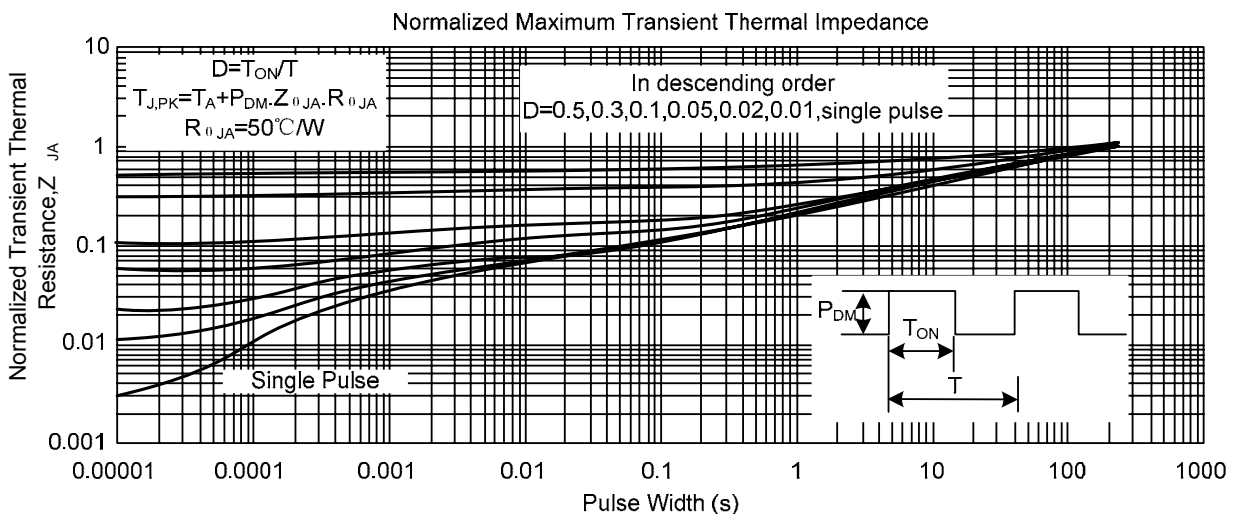
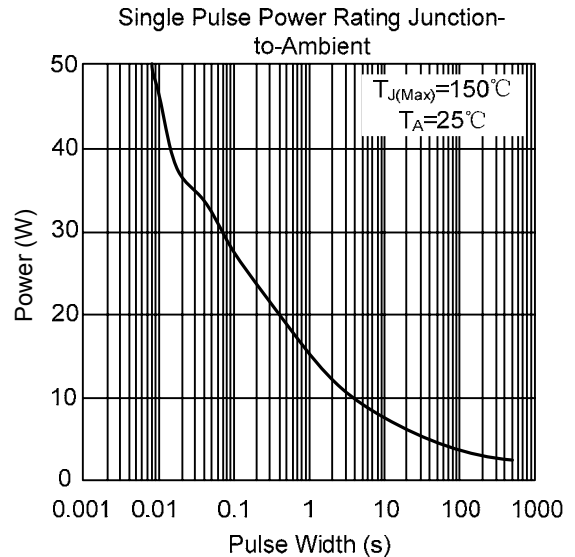
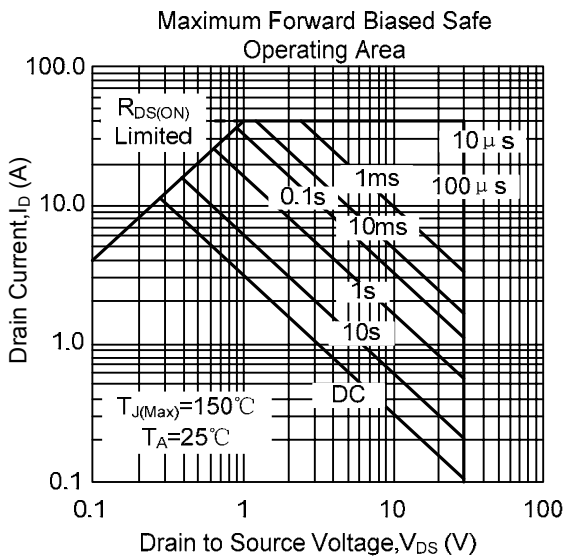
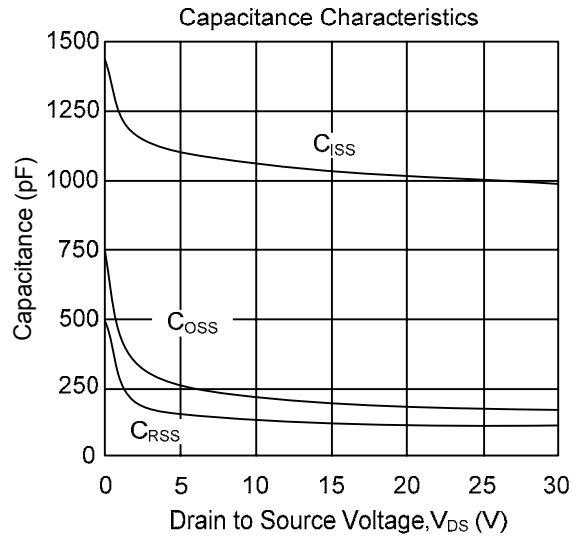
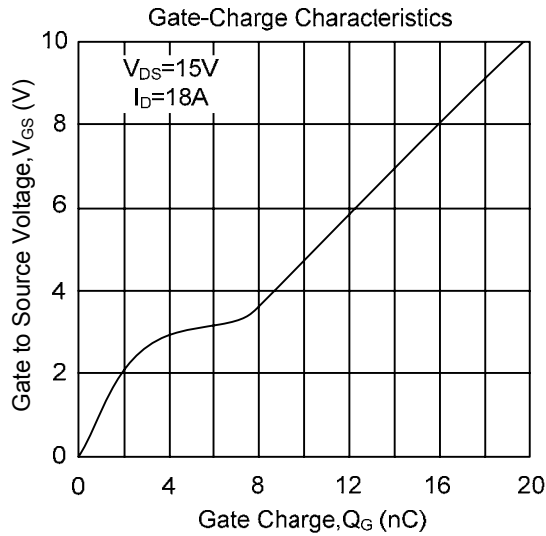

UTC assumes no responsibility for equipment failures that result from using products at values that exceed, even momentarily, rated values (such as maximum ratings, operating condition ranges, or other parameters) listed in products specifications of any and all UTC products described or contained herein. UTC products are not designed for use in life support appliances, devices or systems where malfunction of these products can be reasonably expected to result in personal injury. Reproduction in whole or in part is prohibited without the prior written consent of the copyright owner. The information presented in this document does not form part of any quotation or contract, is believed to be accurate and reliable and may be changed without notice.