



UT3418

Power MOSFET

N-CHANNEL ENHANCEMENT MODE FIELD EFFECT TRANSISTOR

DESCRIPTION

The **UT3418** uses advanced trench technology to provide excellent $R_{DS(ON)}$, low gate charge and operation with low gate voltages. This device is suitable for use as a load switch or in PWM applications.

FEATURES

- * $R_{DS(ON)} < 60m\Omega @ V_{GS} = 10 V$
- $R_{DS(ON)} < 70m\Omega @ V_{GS} = 4.5 V$
- $R_{DS(ON)} < 155m\Omega @ V_{GS} = 2.5 V$
- * Low capacitance
- * Low gate charge
- * Fast switching capability
- * Avalanche energy specified

SYMBOL

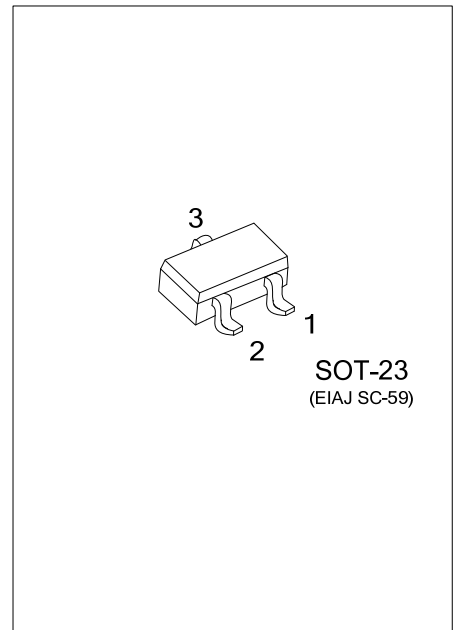
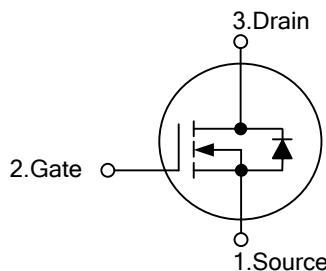

ORDERING INFORMATION

Ordering Number	Package	Pin Assignment			Packing
		1	2	3	
UT3418G-AE3-R	SOT-23	S	G	D	Tape Reel

Note: Pin Assignment: G: Gate D: Drain S: Source

<p>UT3418G-AE3-R</p> <ul style="list-style-type: none"> (1) Packing Type (2) Package Type (3) Green Package 	<ul style="list-style-type: none"> (1) R: Tape Reel (2) AE3: SOT-23 (3) G: Halogen Free and Lead Free
----------------------------------------------------------------------------------------------------------------------------------------------	----------------------------------------------------------------------------------------------------------------------------------------

MARKING

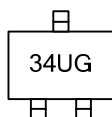

■ ABSOLUTE MAXIMUM RATINGS ($T_A = 25^\circ\text{C}$, unless otherwise specified)

PARAMETER	SYMBOL	RATINGS	UNITS
Drain-Source Voltage	V_{DSS}	30	V
Gate-Source Voltage	V_{GSS}	± 12	V
Continuous Drain Current	I_D	3.8	A
Pulsed Drain Current (Note 2)	I_{DM}	15	A
Power Dissipation	P_D	1.4	W
Junction Temperature	T_J	+150	$^\circ\text{C}$
Storage Temperature	T_{STG}	-55 ~ +150	$^\circ\text{C}$

Notes: 1. Absolute maximum ratings are those values beyond which the device could be permanently damaged.

Absolute maximum ratings are stress ratings only and functional device operation is not implied.

2. Pulse width limited by $T_{J(MAX)}$

■ THERMAL DATA

PARAMETER	SYMBOL	MIN	TYP	MAX	UNIT
Junction to Ambient	θ_{JA}		100	125	$^\circ\text{C/W}$

■ ELECTRICAL CHARACTERISTICS ($T_a=25^\circ\text{C}$, unless otherwise specified)

PARAMETER	SYMBOL	TEST CONDITIONS	MIN	TYP	MAX	UNIT
OFF CHARACTERISTICS						
Drain-Source Breakdown Voltage	BV_{DSS}	$I_D=250\mu\text{A}, V_{GS}=0\text{V}$	30			V
Drain-Source Leakage Current	I_{DSS}	$V_{DS}=24\text{V}, V_{GS}=0\text{V}$		0.001	1	μA
Gate-Source Leakage Current	I_{GSS}	$V_{GS}=\pm 12\text{V}, V_{DS}=0\text{V}$			100	nA
ON CHARACTERISTICS						
Gate-Threshold Voltage	$V_{GS(TH)}$	$V_{DS}=V_{GS}, I_D=250\mu\text{A}$	1	1.4	1.8	V
Drain-Source On-State Resistance	$R_{DS(ON)}$	$V_{GS}=10\text{V}, I_D=3.8\text{A}$		43	60	m Ω
		$V_{GS}=4.5\text{V}, I_D=3.5\text{A}$		52	70	m Ω
		$V_{GS}=2.5\text{V}, I_D=1\text{A}$		101	155	m Ω
On-State Drain Current	$I_{D(ON)}$	$V_{DS}=5\text{V}, V_{GS}=4.5\text{V}$	15			A
DYNAMIC PARAMETERS						
Input Capacitance	C_{ISS}	$V_{DS}=15\text{V}, V_{GS}=0\text{V}, f=1.0\text{MHz}$		226	270	pF
Output Capacitance	C_{OSS}			39		pF
Reverse Transfer Capacitance	C_{RSS}			29		pF
SWITCHING PARAMETERS						
Turn-ON Delay Time	$t_{D(ON)}$	$V_{DS}=15\text{V}, R_L=3.9\Omega,$ $V_{GS}=10\text{V}, R_G=6\Omega$		2.6	4	ns
Turn-ON Rise Time	t_R			3.2	5	ns
Turn-OFF Delay Time	$t_{D(OFF)}$			14.5	22	ns
Turn-OFF Fall-Time	t_F			2.1	3	ns
Total Gate Charge	Q_G	$V_{DS}=15\text{V}, V_{GS}=4.5\text{V},$ $I_D=3.8\text{A}$		3	3.6	nC
Gate Source Charge	Q_{GS}			1.4		nC
Gate Drain Charge	Q_{GD}			0.55		nC
SOURCE- DRAIN DIODE RATINGS AND CHARACTERISTICS						
Diode Forward Voltage	V_{SD}	$I_S=1\text{A}, V_{GS}=0\text{V}$		0.81	1	V
Maximum Body-Diode Continuous Current	I_S				2.5	A
Body Diode Reverse Recovery Time	t_{RR}	$I_F=3.8\text{A}, dI/dt=100\text{A}/\mu\text{s}$		10.2	13	ns
Body Diode Reverse Recovery Charge	Q_{RR}			3.8	5	nC

TYPICAL CHARACTERISTICS

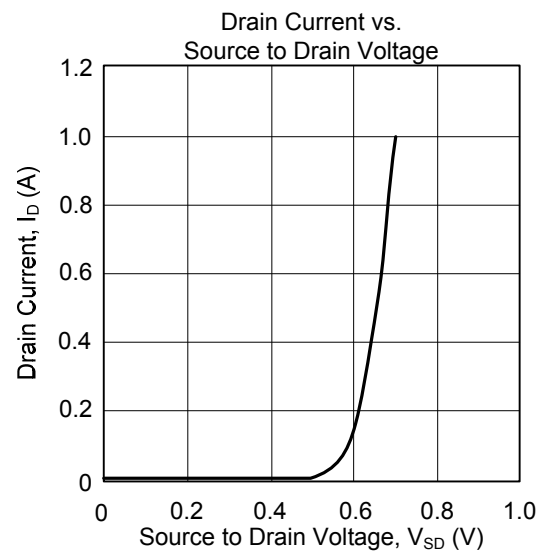
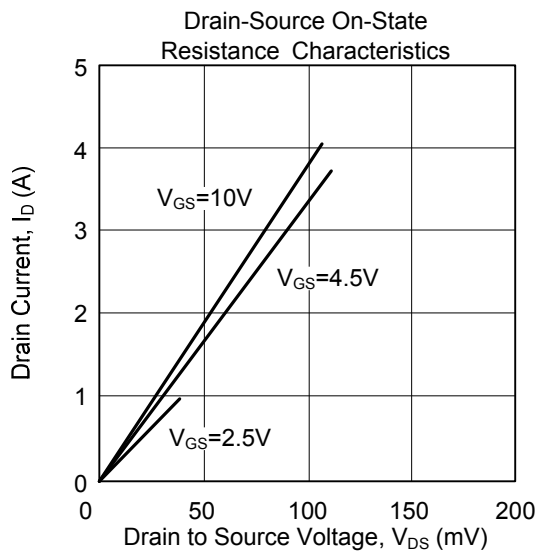
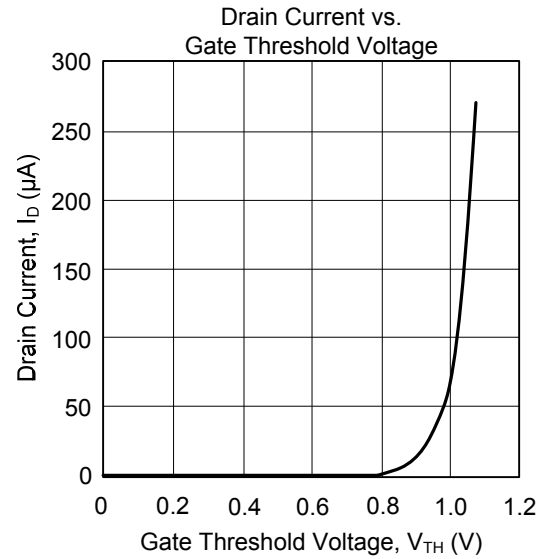
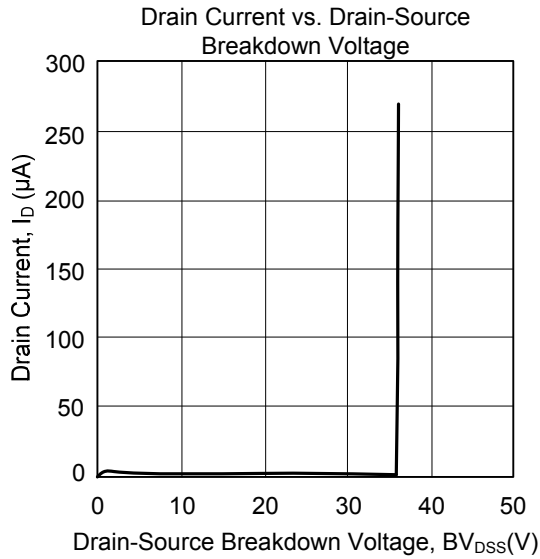

UTC assumes no responsibility for equipment failures that result from using products at values that exceed, even momentarily, rated values (such as maximum ratings, operating condition ranges, or other parameters) listed in products specifications of any and all UTC products described or contained herein. UTC products are not designed for use in life support appliances, devices or systems where malfunction of these products can be reasonably expected to result in personal injury. Reproduction in whole or in part is prohibited without the prior written consent of the copyright owner. The information presented in this document does not form part of any quotation or contract, is believed to be accurate and reliable and may be changed without notice.