



13003ADG

Preliminary

NPN SILICON TRANSISTOR

NPN SILICON POWER TRANSISTOR

DESCRIPTION

These devices are designed for high-voltage, high-speed power switching inductive circuits where fall time is critical. They are particularly suited for 115 and 220V applications in switch mode.

FEATURES

- * Reverse biased SOA with inductive load @ $T_c=100^\circ\text{C}$
- * Inductive switching matrix 0.5 ~ 1.5 Amp, 25 and 100°C
Typical $t_c = 290\text{ns}$ @ 1A, 100°C .
- * 700V blocking capability

APPLICATIONS

- * Switching regulator's, inverters
- * Motor controls
- * Solenoid/relay drivers
- * Deflection circuits

EQUIVALENT CIRCUIT

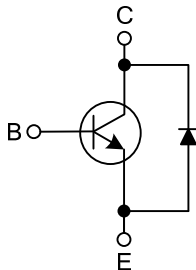

ORDERING INFORMATION

Ordering Number		Package	Pin Assignment			Packing
Lead Free	Halogen Free		1	2	3	
13003ADGL-TM3-T	13003ADGP-TM3-T	TO-251	B	C	E	Tube
13003ADGL-T60-F-K	13003ADGP-T60-F-K	TO-126	B	C	E	Bulk
13003ADGL-T92-F-B	13003ADGP-T92-F-B	TO-92	B	C	E	Tape Box
13003ADGL-T92-F-K	13003ADGP-T92-F-K	TO-92	B	C	E	Bulk

Note: Pin Assignment: B: Base C: Collector E: Emitter

<p>13003ADGL-T60-F-B</p>	<p>(1) T: Tube, B: Bluk, K: Bulk (2) refer to Pin Assignment (3) TM3: TO-251, T60: TO-126, T92: TO-92 (4) L: Lead Free, P: Halogen Free</p>
--------------------------	--

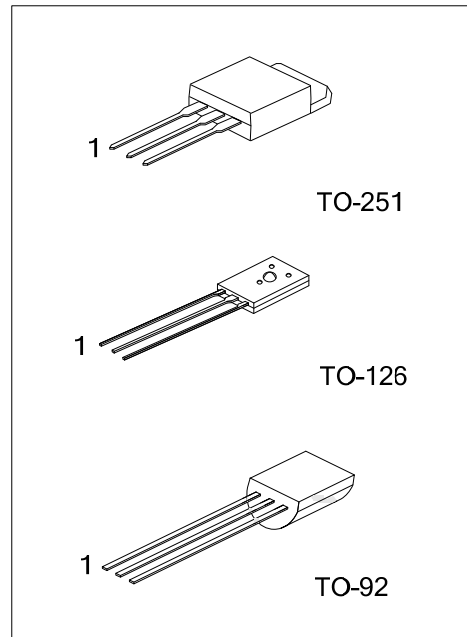

MARKING

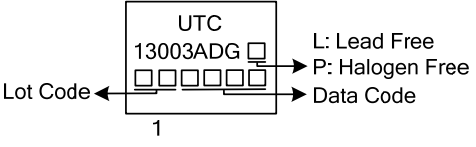
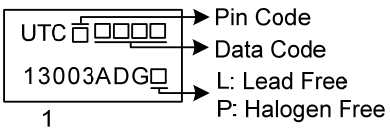
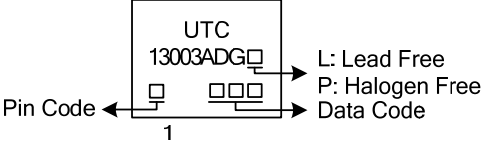
PACKAGE	MARKING
TO-251	 <p>Diagram showing marking on a TO-251 package. The marking includes 'UTC', '13003ADG', and a Lot Code (four squares). A '1' is at the bottom. Arrows point to 'L: Lead Free', 'P: Halogen Free', and 'Data Code'.</p>
TO-126	 <p>Diagram showing marking on a TO-126 package. The marking includes 'UTC', '13003ADG', and a Pin Code (four squares). A '1' is at the bottom. Arrows point to 'Pin Code', 'Data Code', 'L: Lead Free', and 'P: Halogen Free'.</p>
TO-92	 <p>Diagram showing marking on a TO-92 package. The marking includes 'UTC', '13003ADG', and a Pin Code (two squares). A '1' is at the bottom. Arrows point to 'L: Lead Free', 'P: Halogen Free', and 'Data Code'.</p>

■ ABSOLUTE MAXIMUM RATINGS

PARAMETER		SYMBOL	RATINGS	UNIT	
Collector-Emitter Voltage		$V_{CEO(SUS)}$	400	V	
Collector-Base Voltage		V_{CBO}	700	V	
Emitter Base Voltage		V_{EBO}	9	V	
Collector Current	Continuous	I_C	1.5	A	
	Peak (1)	I_{CM}	3		
Base Current	Continuous	I_B	0.75	A	
	Peak (1)	I_{BM}	1.5		
Emitter Current	Continuous	I_E	2.25	A	
	Peak (1)	I_{EM}	4.5		
Power Dissipation	$T_A=25^\circ\text{C}$	TO-126	P_D	1.4	W
		TO-92		1.1	W
		TO-251		1.56	W
	$T_C=25^\circ\text{C}$	TO-126		20	W
		TO-92		1.5	W
		TO-251		25	W
Junction Temperature		T_J	+150	$^\circ\text{C}$	
Storage Temperature		T_{STG}	-55 ~ +150	$^\circ\text{C}$	

Note: Absolute maximum ratings are those values beyond which the device could be permanently damaged.
 Absolute maximum ratings are stress ratings only and functional device operation is not implied.

■ ELECTRICAL CHARACTERISTICS ($T_C=25^\circ\text{C}$, unless otherwise specified.)

PARAMETER	SYMBOL	TEST CONDITIONS	MIN	TYP	MAX	UNIT
OFF CHARACTERISTICS (Note)						
Collector-Emitter Sustaining Voltage	$V_{CE(SUS)}$	$I_C=10\text{mA}$, $I_B=0$	400			V
Collector Cutoff Current	I_{CEO}	$V_{CEO}=\text{Rated Value}$, $V_{BE(OFF)}=1.5\text{V}$			1	mA
			$T_C=25^\circ\text{C}$		5	
Emitter Cutoff Current	I_{EBO}	$V_{EB}=9\text{V}$, $I_C=0$			1	mA
SECOND BREAKDOWN						
Second Breakdown Collector Current with base forward biased	$I_{S/b}$			See Fig.5		
Clamped Inductive SOA with base reverse biased	RB_{SOA}			See Fig.6		
ON CHARACTERISTICS (Note)						
DC Current Gain	h_{FE1}	$I_C=0.5\text{A}$, $V_{CE}=5\text{V}$	14		57	
	h_{FE2}	$I_C=1\text{A}$, $V_{CE}=5\text{V}$	5		30	
Collector-Emitter Saturation Voltage	$V_{CE(SAT)}$	$I_C=0.5\text{A}$, $I_B=0.1\text{A}$			0.5	V
		$I_C=1\text{A}$, $I_B=0.25\text{A}$			1	
		$I_C=1.5\text{A}$, $I_B=0.5\text{A}$			3	
		$I_C=1\text{A}$, $I_B=0.25\text{A}$, $T_C=100^\circ\text{C}$			1	
Base-Emitter Saturation Voltage	$V_{BE(SAT)}$	$I_C=0.5\text{A}$, $I_B=0.1\text{A}$			1	V
		$I_C=1\text{A}$, $I_B=0.25\text{A}$			1.2	
		$I_C=1\text{A}$, $I_B=0.25\text{A}$, $T_C=100^\circ\text{C}$			1.1	
DYNAMIC CHARACTERISTICS						
Current-Gain-Bandwidth Product	f_T	$I_C=100\text{mA}$, $V_{CE}=10\text{V}$, $f=1\text{MHz}$	4	10		MHz
Output Capacitance	C_{OB}	$V_{CB}=10\text{V}$, $I_E=0$, $f=0.1\text{MHz}$		21		pF
SWITCHING CHARACTERISTICS						
Resistive Load (Table 1)						
Delay Time	t_D	$V_{CC}=125\text{V}$, $I_C=1\text{A}$, $I_{B1}=I_{B2}=0.2\text{A}$, $t_P=25\mu\text{s}$, Duty Cycle $\leq 1\%$		0.05	0.1	μs
Rise Time	t_R			0.5	1	μs
Storage Time	t_S			2	4	μs
Fall Time	t_F			0.4	0.7	μs
Inductive Load, Clamped (Table 1)						
Storage Time	t_{STG}	$I_C=1\text{A}$, $V_{CLAMP}=300\text{V}$, $I_{B1}=0.2\text{A}$, $V_{BE(OFF)}=5V_{DC}$, $T_C=100^\circ\text{C}$		1.7	4	μs
Crossover Time	t_C			0.29	0.75	μs
Fall Time	t_F			0.15		μs
Diode Forward Voltage	V_F	$I_F=0.5\text{A}$			1.5	V

Note: Pulse Test: $PW=300\mu\text{s}$, Duty Cycle $\leq 2\%$

UTC assumes no responsibility for equipment failures that result from using products at values that exceed, even momentarily, rated values (such as maximum ratings, operating condition ranges, or other parameters) listed in products specifications of any and all UTC products described or contained herein. UTC products are not designed for use in life support appliances, devices or systems where malfunction of these products can be reasonably expected to result in personal injury. Reproduction in whole or in part is prohibited without the prior written consent of the copyright owner. The information presented in this document does not form part of any quotation or contract, is believed to be accurate and reliable and may be changed without notice.