



2SC5353

NPN SILICON TRANSISTOR

HIGH VOLTAGE NPN TRANSISTOR

DESCRIPTION

Switching Regulator and High Voltage Switching Applications
High-Speed DC-DC Converter Applications

FEATURES

- * Excellent switching times: $t_R = 0.7\mu s_{(MAX)}$, $t_F = 0.5\mu s_{(MAX)}$
- * High collectors breakdown voltage: $V_{CEO} = 700V$

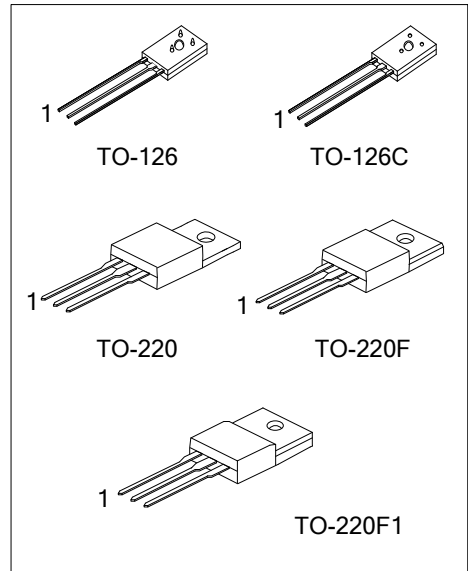

ORDERING INFORMATION

Ordering Number		Package	Pin Assignment			Packing
Lead Free	Halogen Free		1	2	3	
2SC5353L-T60-K	2SC5353G-T60-K	TO-126	B	C	E	Bulk
2SC5353L-T6C-K	2SC5353G-T6C-K	TO-126C	B	C	E	Bulk
2SC5353L-TA3-T	2SC5353G-TA3-T	TO-220	B	C	E	Tube
2SC5353L-TF3-T	2SC5353G-TF3-T	TO-220F	B	C	E	Tube
2SC5353L-TF1-T	2SC5353G-TF1-T	TO-220F1	B	C	E	Tube

<p>2SC5353L-T60-T</p> <p>(1)Packing Type (2)Package Type (3)Lead Free</p>	<p>(1) K: Bulk, T: Tube (2) T60: TO-126, T6C: TO-126C, TA3: TO-220, TF3: TO-220F, TF1: TO-220F1 (3) L: Lead Free, G: Halogen Free</p>
---	---

■ ABSOLUTE MAXIMUM RATINGS (T_C=25°C)

PARAMETER		SYMBOL	RATINGS	UNIT
Collector-Base Voltage		V _{CBO}	900	V
Collector-Emitter Voltage		V _{CEO}	700	V
Emitter-Base Voltage		V _{EBO}	7	V
Collector Current	DC	I _C	3	A
	Pulse	I _{CP}	5	
Base Current		I _B	1	A
Collector Power Dissipation	TO-220F/ TO-220F1	P _D	20	W
	TO-126/TO-126C			
	TO-220		25	
Junction Temperature		T _J	+150	°C
Storage Temperature		T _{STG}	-40 ~ +150	°C

Note: Absolute maximum ratings are those values beyond which the device could be permanently damaged. Absolute maximum ratings are stress ratings only and functional device operation is not implied.

■ ELECTRICAL CHARACTERISTICS (T_C=25°C)

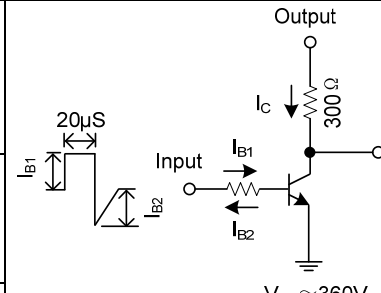
PARAMETER		SYMBOL	TEST CONDITIONS	MIN	TYP	MAX	UNIT
Collector-Base Breakdown Voltage		BV _{CBO}	I _C =1 mA, I _E = 0	900			V
Collector-Emitter Breakdown Voltage		BV _{CEO}	I _C =10 mA, I _B = 0	700			V
Collector Cut-off Current		I _{CBO}	V _{CB} =720V, I _E = 0			100	μA
Emitter Cut-off Current		I _{EBO}	V _{EB} =7V, I _C = 0			10	μA
DC Current Gain		h _{FE1}	V _{CE} =5 V, I _C =1 mA	10			
		h _{FE2}	V _{CE} =5 V, I _C =0.15 A	15			
Collector-Emitter Saturation Voltage		V _{CE(SAT)}	I _C =1.2 A, I _B =0.24 A			1.0	V
Base-Emitter Saturation Voltage		V _{BE(SAT)}	I _C =1.2 A, I _B =0.24 A			1.3	V
Switching Time	Rise Time	t _r	 <p>I_{B1} = 0.24 A, I_{B2} = -0.48 A, duty cycle ≤ 1%</p>			0.7	μS
	Storage Time	t _{STG}				4.0	
	Fall Time	t _f				0.5	

TYPICAL CHARACTERISTICS

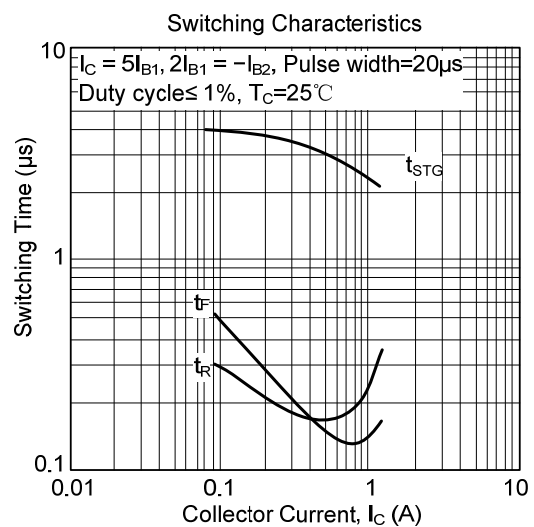
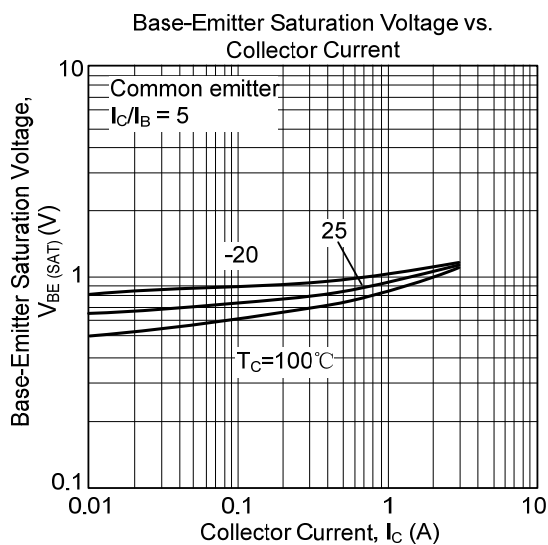
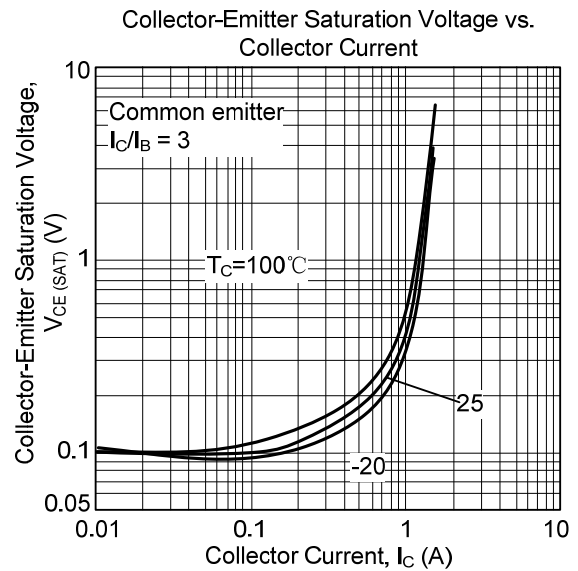
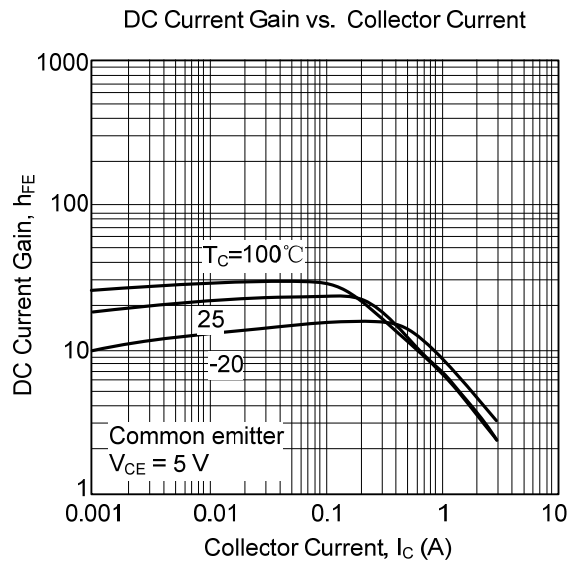
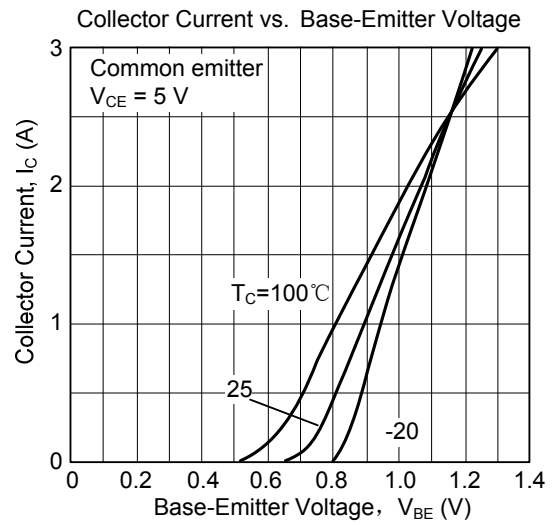
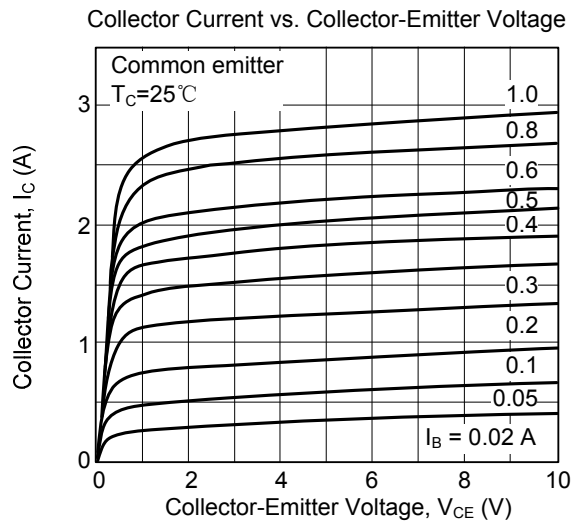

■ TYPICAL CHARACTERISTICS(Cont.)

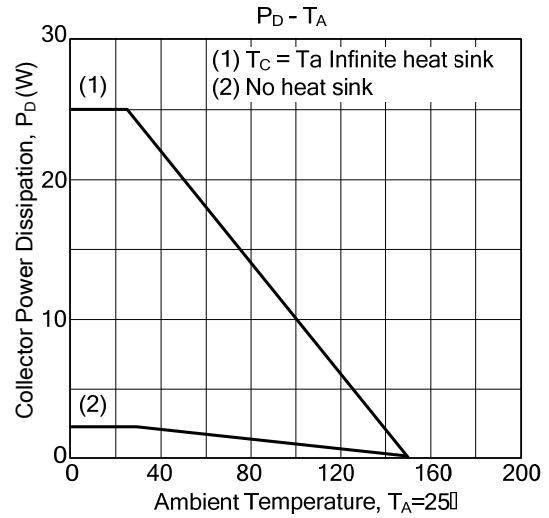
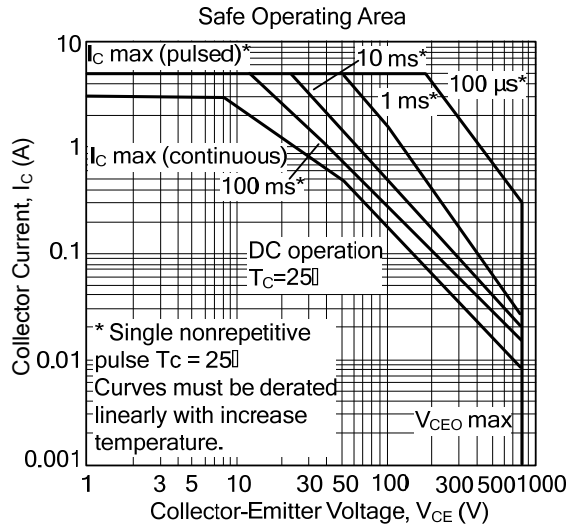

UTC assumes no responsibility for equipment failures that result from using products at values that exceed, even momentarily, rated values (such as maximum ratings, operating condition ranges, or other parameters) listed in products specifications of any and all UTC products described or contained herein. UTC products are not designed for use in life support appliances, devices or systems where malfunction of these products can be reasonably expected to result in personal injury. Reproduction in whole or in part is prohibited without the prior written consent of the copyright owner. The information presented in this document does not form part of any quotation or contract, is believed to be accurate and reliable and may be changed without notice.