



2SA1797

PNP SILICON TRANSISTOR

POWER TRANSISTOR

■ FEATURES

- * Low Saturation Voltage.
 $V_{CE(SAT)} = -0.35V(MAX)$ at $I_C / I_B = -1A / -50mA$
- * Excellent DC Current Gain Characteristics

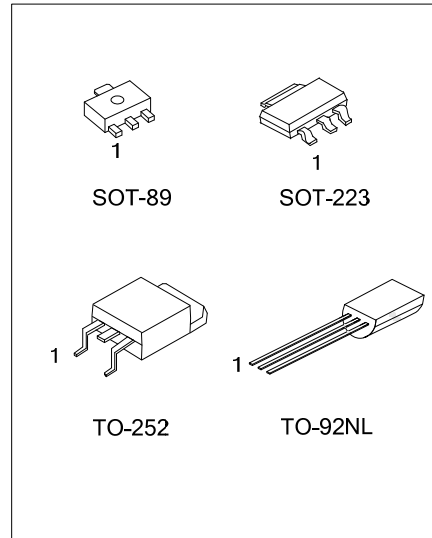

■ ORDERING INFORMATION

Ordering Number		Package	Pin Assignment			Packing
Lead Free	Halogen Free		1	2	3	
-	2SA1797G-x-AA3-R	SOT-223	B	C	E	Tape Reel
-	2SA1797G-x-AB3-R	SOT-89	B	C	E	Tape Reel
2SA1797L-x-T9N-B	2SA1797G-x-T9N-B	TO-92NL	E	C	B	Tape Box
2SA1797L-x-T9N-K	2SA1797G-x-T9N-K	TO-92NL	E	C	B	Bulk
2SA1797L-x-TN3-R	2SA1797G-x-TN3-R	TO-252	B	C	E	Tape Reel

Note: Pin Assignment: B: Base C: Collector E: Emitter

<p>2SA1797G-x-AA3-R</p> <p>(1) Packing Type (2) Package Type (3) Rank (4) Green Package</p>	<p>(1) R: Tape Reel, B: Tape Box, K: Bulk (2) AA3: SOT-223, AB3: SOT-89, T9N: TO-92NL, TN3: TO-252 (3) refer to Classification of hFE (4) G: Halogen Free and Lead Free, L: Lead Free</p>
--	--

■ MARKING

<p>SOT-89</p>	<p>SOT-223</p>
<p>TO-252</p>	<p>TO-92NL</p>

■ ABSOLUTE MAXIMUM RATINGS ($T_A=25^{\circ}\text{C}$, unless otherwise specified)

PARAMETER		SYMBOL	RATINGS	UNIT
Collector-Base Voltage		V_{CBO}	-50	V
Collector-Emitter Voltage		V_{CEO}	-50	V
Emitter-Base Voltage		V_{EBO}	-6	V
Collector Current	DC	I_C	-2	A
	PULSE(Note 1)		-5	A
Collector Power Dissipation	TO-92NL	P_C	1	W
	SOT-223		0.8	W
	SOT-89		0.5	W
	TO-252		1.9	W
Junction Temperature		T_J	150	$^{\circ}\text{C}$
Storage Temperature		T_{STG}	-55 ~ +150	$^{\circ}\text{C}$

Note: 1. Single pulse, $P_W=10\text{ms}$

2. Absolute maximum ratings are those values beyond which the device could be permanently damaged.
Absolute maximum ratings are stress ratings only and functional device operation is not implied.

■ ELECTRICAL CHARACTERISTICS ($T_A=25^{\circ}\text{C}$, unless otherwise specified)

PARAMETER	SYMBOL	TEST CONDITIONS	MIN	TYP	MAX	UNIT
Collector-Base Breakdown Voltage	BV_{CBO}	$I_C = -50\mu\text{A}$	-50			V
Collector-Emitter Breakdown Voltage	BV_{CEO}	$I_C = -1\text{mA}$	-50			V
Emitter-Base Breakdown Voltage	BV_{EBO}	$I_E = -50\mu\text{A}$	-6			V
Collector Cutoff Current	I_{CBO}	$V_{CB} = -50\text{V}$			-0.1	μA
Emitter Cutoff Current	I_{EBO}	$V_{EB} = -5\text{V}$			-0.1	μA
Collector-Emitter Saturation Voltage	$V_{CE(SAT)}$	$I_C/I_B = -1\text{A}/-50\text{mA}$ (Note)		-0.15	-0.35	V
DC Current Gain	h_{FE}	$V_{CE} = -2\text{V}, I_C = -0.5\text{A}$ (Note)	120		400	
Transition Frequency	f_T	$V_{CE} = -2\text{V}, I_E = 0.5\text{A}, f = 100\text{MHz}$		200		MHz
Output Capacitance	C_{OB}	$V_{CB} = -10\text{V}, I_E = 0\text{A}, f = 1\text{MHz}$		36		pF

Note: Measured using pulse current.

■ CLASSIFICATION OF h_{FE}

RANK	A	B
RANGE	120-240	200-400

TYPICAL CHARACTERISTICS

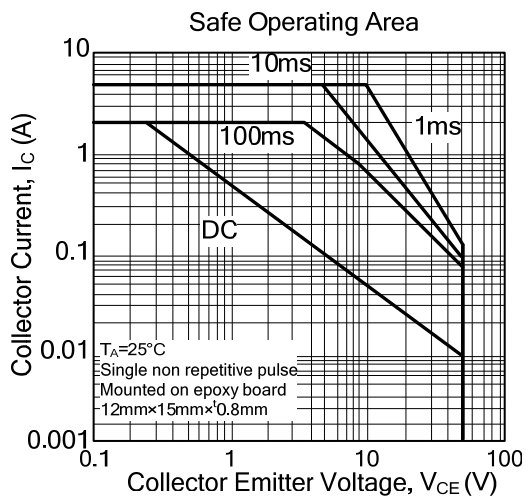
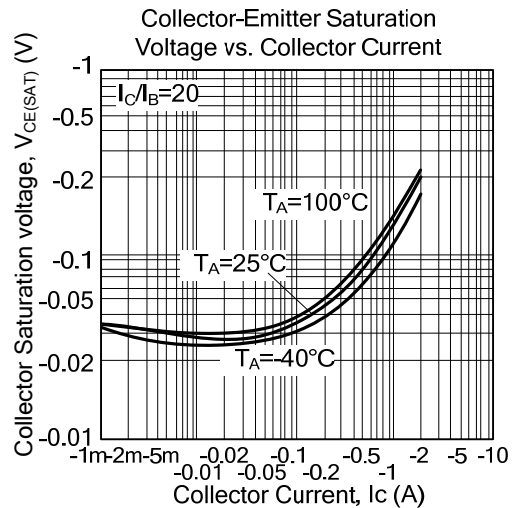
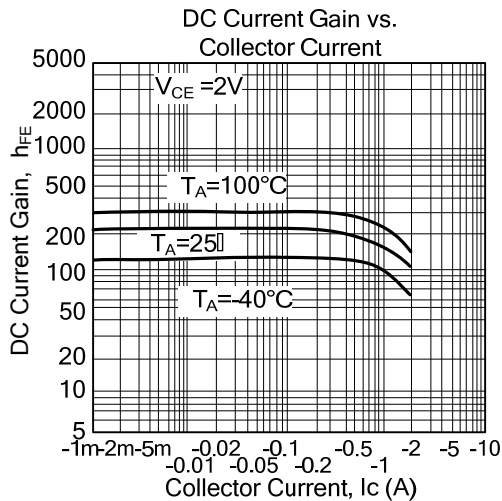
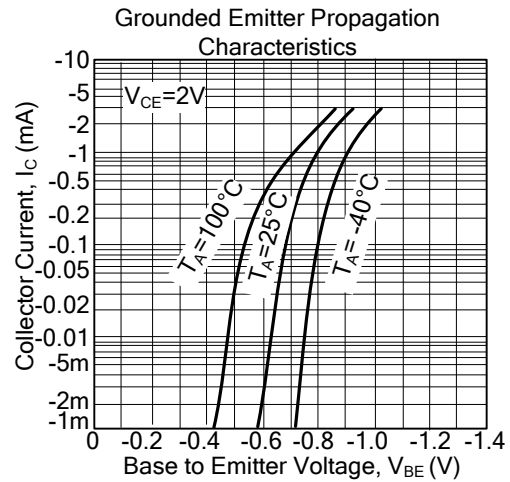
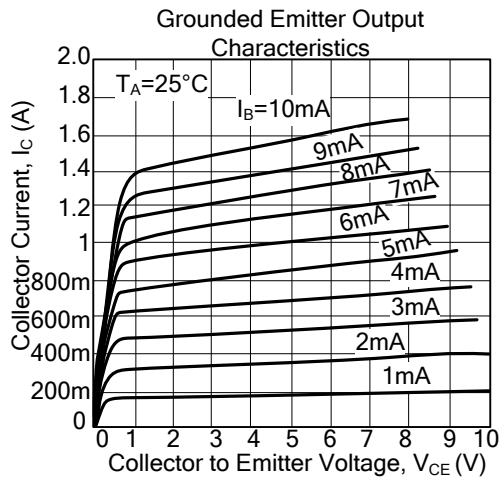

UTC assumes no responsibility for equipment failures that result from using products at values that exceed, even momentarily, rated values (such as maximum ratings, operating condition ranges, or other parameters) listed in products specifications of any and all UTC products described or contained herein. UTC products are not designed for use in life support appliances, devices or systems where malfunction of these products can be reasonably expected to result in personal injury. Reproduction in whole or in part is prohibited without the prior written consent of the copyright owner. The information presented in this document does not form part of any quotation or contract, is believed to be accurate and reliable and may be changed without notice.