

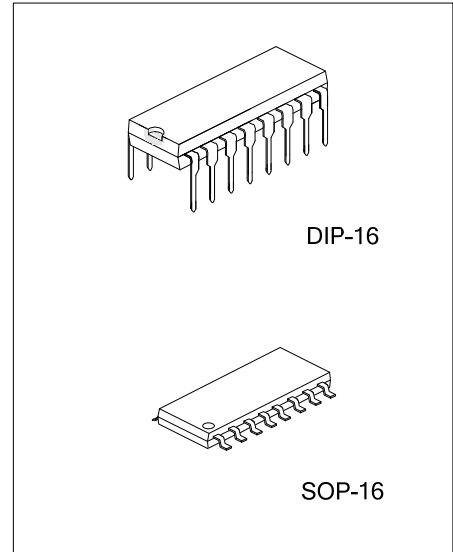

UM602A

LINEAR INTEGRATED CIRCUIT

DUAL OPERATIONAL
AMPLIFIER-DUAL
COMPARATOR AND
ADJUSTABLE VOLTAGE
REFERENCE



DESCRIPTION

The UTC **UM602A** is a monolithic IC that includes two op-amps, two comparators and a precision voltage reference. This device is offering space and cost saving in many applications like power supply management or data acquisition systems.

FEATURES

OPERATIONAL AMPLIFIERS

- *Low supply current: 200 μ A/amp.
- *Medium speed: 2.1MHz
- *Low level output voltage close to V_{CC} : 0.1V typ.
- *Input common mode voltage range includes ground

COMPARATORS

- *Low supply current: 200 μ A/amp. ($V_{CC}=5V$)
- *Input common mode voltage range includes ground
- *Low output saturation voltage: 250mV($I_O=4mA$)

REFERENCE

- * Adjustable output voltage: V_{REF} to 32V
- * Reference voltage tolerance
 - UM602A-1: $\pm 0.4\%$
 - UM602A-2: $\pm 1\%$
- * Sink current capability: 1~100mA

ORDERING INFORMATION

Ordering Number		Package	Packing
Lead Free	Halogen Free		
UM602AL-D16-T	UM602AG-D16-T	DIP-16	Tube
-	UM602AG-S16-R	SOP-16	Tape Reel

<p>UM602AL-D16-T</p> <p>(1)Packing Type (2)Package Type (3)Green Package</p>	<p>(1) T: Tube, R: Tape Reel (2) D16: DIP-16, S16: SOP-16 (3) L: Lead Free, G: Halogen Free and Lead Free</p>
--	---

MARKING

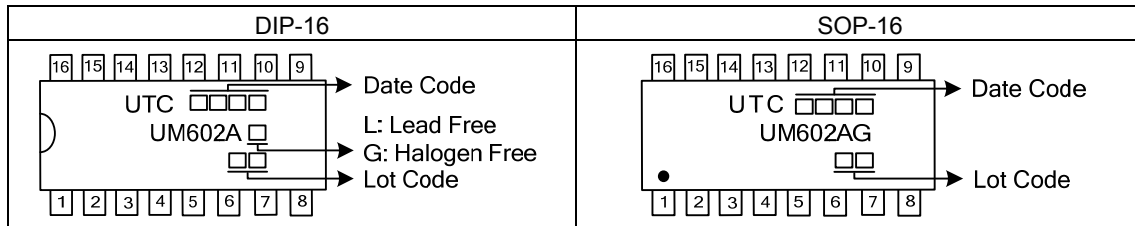

PIN CONFIGURATION

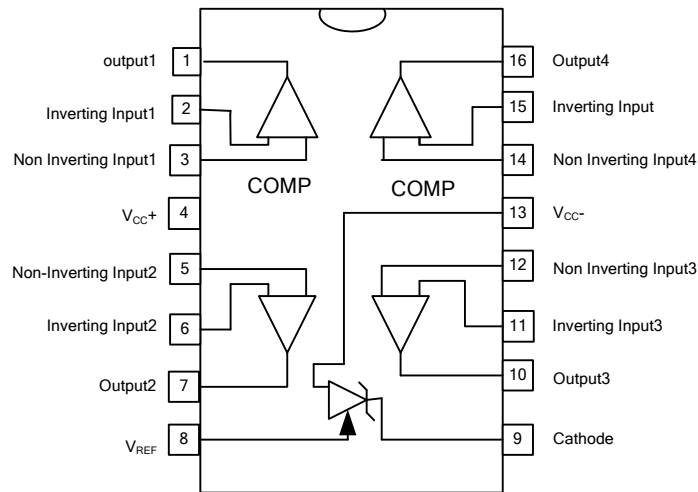

PIN DESCRIPTION

PIN	NAME	TYPE	FUNCTION
1.	V_{REF}	OUTPUT	Voltage Reference Output 1.24V, 10mA max. Do not short circuit
2.	C_{SEN}	INPUT	Current source enable input. This current source can be used to offset the voltage measurement on the sense resistor and therefore to modify the charge current. The current source is enabled when the input voltage on pin 2 is lower than 0.8V
3.	C_{RREF}	INPUT	Current Limitation Reference Input
4.	GND	INPUT	Ground
5.	C_{RIN}	INPUT	Current Limitation Loop Input, connected to the sense resistor
6.	OUTPUT	OUTPUT	Output pin common to the voltage regulation and current limitation loops. This output can drive the primary side (LED) of an optocoupler
7.	V_{RIN}	INPUT	Voltage Regulation Loop Input
8.	V_{CC}	INPUT	Power Supply Input (4.5 ~ 32VDC)

■ ABSOLUTE MAXIMUM RATING ($T_A=25^\circ\text{C}$, unless otherwise specified)

PARAMETER	SYMBOL	RATINGS	UNIT
DC Supply Voltage	V_{CC}	36	V
Differential Input Voltage	V_{ID}	36	V
Input Voltage	V_{IN}	-0.3 ~ +36	V
Power Dissipation	P_D	200	mW
Junction Temperature	T_J	150	$^\circ\text{C}$
Operating Temperature Range	T_{OPR}	-40 ~ +125	$^\circ\text{C}$

Note: Absolute maximum ratings are those values beyond which the device could be permanently damaged. Absolute maximum ratings are stress ratings only and functional device operation is not implied.

■ ELECTRICAL CHARACTERISTICS ($V_{CC}^+=5\text{V}$, $V_{CC}^-=\text{GND}$, $T_A=25^\circ\text{C}$, unless otherwise specified)

PARAMETER	SYMBOL	TEST CONDITIONS	MIN	TYP	MAX	UNIT
Total Supply Current	I_{CC}			0.8	1.5	mA
		$T_{MIN} < T_A < T_{MAX}$			2	mA

■ OPERATIONAL AMPLIFIERS (Independent op-amp)

($V_{CC}^+=5\text{V}$, $V_{CC}^-=0\text{V}$, R_1 Connected to $V_{CC}/2$, $T_A=25^\circ\text{C}$, unless otherwise specified)

PARAMETER	SYMBOL	TEST CONDITIONS	MIN	TYP	MAX	UNIT
Input Offset Voltage	V_{IO}	$T_A=25^\circ\text{C}$		1	4.5	mV
		$T_{MIN} \leq T_A \leq T_{MAX}$			6.5	mV
Input Offset Voltage Drift	DV_{IO}			10		$\mu\text{V}/^\circ\text{C}$
Input Bias Current	I_{IB}	$T_A=25^\circ\text{C}$		20	100	nA
		$T_{MIN} \leq T_A \leq T_{MAX}$			200	nA
Input Offset Current	I_{IO}	$T_A=25^\circ\text{C}$		5	20	nA
		$T_{MIN} \leq T_A \leq T_{MAX}$			40	nA
Large Signal Voltage Gain	A_{VD}	$R_1=10\text{k}\Omega$, $V_{CC}^+=30\text{V}$, $V_O=5\text{V}\sim 25\text{V}$	50	100		V/mV
		$T_{MIN} \leq T_A \leq T_{MAX}$	25			V/mV
Supply Voltage Rejection Ratio	SVR	$V_O=5\text{V}\sim 30\text{V}$	80	100		dB
Input Common Mode Voltage Range	V_{ICM}	$T_A=25^\circ\text{C}$	V_{CC}^-		V_{CC}^+ -1.8	V
		$T_{MIN} \leq T_A \leq T_{MAX}$	V_{CC}^-		V_{CC}^+ -2.2	V
Common Mode Rejection Ratio	CMR	$V_{CC}^+=30\text{V}$, $V_{ICM}=0\text{V}\sim(V_{CC}^+)-1.8\text{V}$	70	90		dB
Output Short Circuit Current	I_{SC}	$V_{ID}=\pm 1\text{V}$, $V_O=2.5\text{V}$	Source	3	6	mA
			Sink	3	6	mA
High Level Output Voltage	V_{OH}	$V_{CC}^+=30\text{V}$	$R_L=10\text{k}\Omega$	27	28	V
			$T_{MIN} \leq T_A \leq T_{MAX}$	26		V
Low Level Output Voltage	V_{OL}	$R_L=10\text{k}\Omega$		100	150	mV
			$T_{MIN} \leq T_A \leq T_{MAX}$			210
Slew Rate	SR	$V_{CC}=\pm 15\text{V}$, $V_I=\pm 10\text{V}$, $R_L=10\text{k}\Omega$, $C_L=100\text{pF}$	1.6	2		V/ μs
Gain Bandwidth Product	GBP	$R_L=10\text{k}\Omega$, $C_L=100\text{pF}$, $f=100\text{kHz}$	1.4	2.1		MHz
Phase Margin	Φ_m	$R_L=10\text{k}\Omega$, $C_L=100\text{pF}$		45		Degrees
Total Harmonic Distortion	THD			0.05		%
Equivalent Input Noise Voltage	e_n	$f=1\text{kHz}$		29		$\frac{nV}{\sqrt{\text{Hz}}}$
Channel Separation	CS			120		dB

■ COMPARATORS

($V_{CC} = +5V$, $V_{CC} = \text{Ground}$, $T_A = 25^\circ\text{C}$, unless otherwise specified)

PARAMETER	SYMBOL	TEST CONDITIONS	MIN	TYP	MAX	UNIT
Input Offset Voltage	V_{IO}	$T_A = 25^\circ\text{C}$			5	MV
		$T_{MIN} \leq T_A \leq T_{MAX}$			9	MV
Input Offset Current	I_{IO}	$T_A = 25^\circ\text{C}$			50	nA
		$T_{MIN} \leq T_A \leq T_{MAX}$			150	nA
Input Bias Current	I_{IB}	$T_A = 25^\circ\text{C}$			250	nA
		$T_{MIN} \leq T_A \leq T_{MAX}$				nA
High Level Output Voltage	I_{OH}	$V_{ID} = 1V$, $V_{CC} = V_O + 30V$		0.1		nA
		$T_{MIN} \leq T_A \leq T_{MAX}$			1	μA
Low Level Output Voltage	V_{OL}	$V_{ID} = -1V$, $I_{sink} = 4\text{mA}$		250	400	mV
		$T_{MIN} \leq T_A \leq T_{MAX}$			700	
Large Signal Voltage Gain	A_{VD}	$R_1 = 15K$, $V_{CC} = 15V$, $V_O = 1 \sim 11V$		200		V/mV
Output Sink Current	I_{SINK}	$V_{ID} = -1V$, $V_O = 1.5V$	6	16		mA
Input Common Mode Voltage Range	V_{ICM}	$T_A = 25^\circ\text{C}$	0		V_{CC}^+ -1.5	V
		$T_{MIN} \leq T_A \leq T_{MAX}$	0		V_{CC}^+ -2	V
Differential Input Voltage	V_{ID}				V_{CC}^+	V
Response Time (Note1)	t_{RE}	$R_1 = 5.1k \sim V_{CC}^+$, $V_{REF} = 1.4V$		1.3		μs
Large Signal Response Time	t_{REL}	$V_{REF} = 1.4V$, $V_I = \text{TTL}$, $R_1 = 5.1k \sim V_{CC}^+$		300		ns

Notes: 1. The response time specified is for 100mV input step with 5mV overdrive.

2. For larger overdrive signals, 300ns can be obtained.

■ VOLTAGE REFERENCE

PARAMETER	SYMBOL	VALUE	UNIT
Cathode to Anode Voltage	V_{KA}	$V_{REF} \sim 36$	V
Cathode Current	I_K	1 to 100	mA

■ VOLTAGE REFERENCE (Cont.)

(T_A=25°C, unless otherwise specified)

PARAMETER	SYMBOL	CONDITION	MIN	TYP	MAX	UNIT	
Reference Input Voltage (T _A =25°C) (Figure 1)	V _{REF}	V _{KA} =V _{REF} , I _K =10mA	UM602A-1	2.490	2.500	2.510	V
			UM602A-2	2.475	2.500	2.525	V
Reference Input Voltage Deviation Over Temperature Range (Figure 1, Note 1)	ΔV _{REF}	V _{KA} =V _{REF} , I _K =10mA T _{MIN} ≤ T _A ≤ T _{MAX}		7	30	mV	
Temperature Coefficient of Reference Input Voltage (Note 2)	$\frac{\Delta V_{REF}}{\Delta T}$	V _{KA} =V _{REF} , I _K =10mA T _{MIN} ≤ T _A ≤ T _{MAX}		±22	±100	ppm/°C	
Ratio of Change in Reference Input Voltage to Change in Cathode to Anode Voltage (Figure2)	$\frac{\Delta V_{REF}}{\Delta V_{KA}}$	I _K =10mA, ΔV _{KA} =36~3V		-1.1	-2	mV/V	
Reference Input Current (Figure2)	I _{REF}	I _K =10mA, R ₁ =10kΩ, R ₂ =∞	T _A =25°C		1.5	2.5	μA
			T _{MIN} ≤ T _A ≤ T _{MAX}			3	μA
Reference Input Current Deviation Over Temperature Range (Figure 2)	ΔI _{REF}	I _K =10mA, R ₁ =10kΩ, R ₂ =∞, T _{MIN} ≤ T _A ≤ T _{MAX}		0.5	1	μA	
Minimum Cathode Current for Regulation-(figure1)	I _{MIN}	V _{KA} =V _{REF}		0.5	1	mA	
Off-State Cathode Current (Figure 3)	I _{OFF}			180	500	nA	

Notes: 1. ΔV_{REF} is defined as the difference between the maximum and minimum values obtained over the full temperature range.

$$V_{REF} = V_{REFMAX} - V_{REFMIN}$$

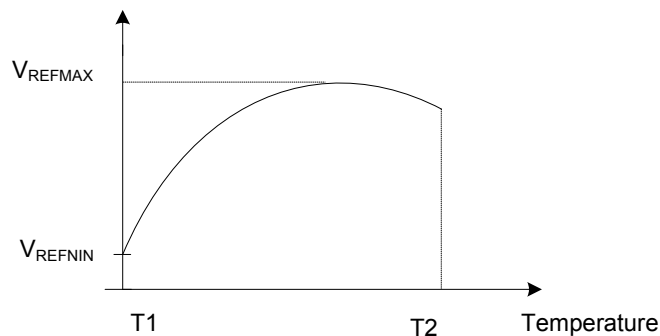

2. The temperature coefficient is defined as the slopes (positive and negative) of the voltage vs temperature limits within which the reference voltage is guaranteed.

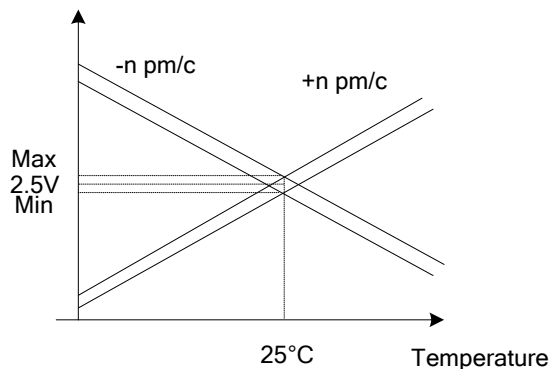

3. The dynamic Impedance is defined as $|Z_{KA}| = \frac{\Delta V_{KA}}{\Delta I_K}$.

■ VOLTAGE REFERENCE (Cont.)

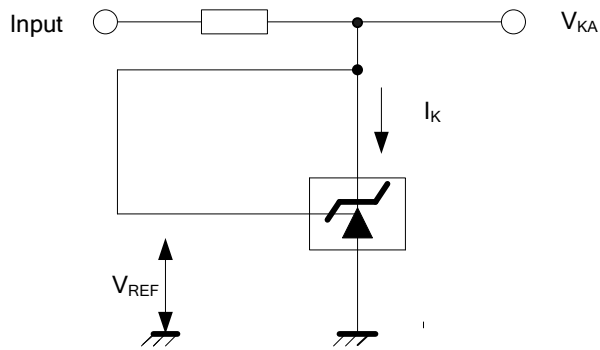

Figure 1: Test Circuit for $V_{KA}=V_{REF}$

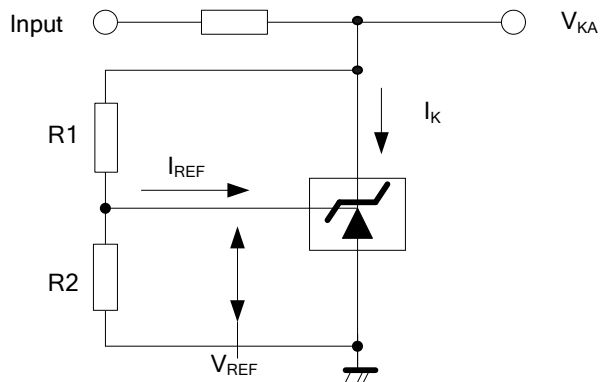

Figure 2: Test Circuit for $V_{KA}>V_{REF}$

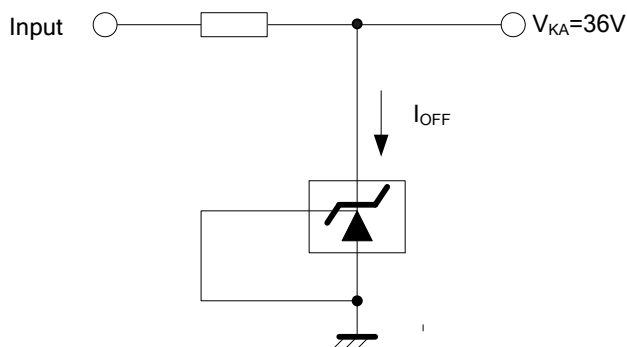

Figure 3: Test Circuit for I_{off}

UTC assumes no responsibility for equipment failures that result from using products at values that exceed, even momentarily, rated values (such as maximum ratings, operating condition ranges, or other parameters) listed in products specifications of any and all UTC products described or contained herein. UTC products are not designed for use in life support appliances, devices or systems where malfunction of these products can be reasonably expected to result in personal injury. Reproduction in whole or in part is prohibited without the prior written consent of the copyright owner. The information presented in this document does not form part of any quotation or contract, is believed to be accurate and reliable and may be changed without notice.