



UPC1237

Preliminary

LINEAR INTEGRATED CIRCUIT

PROTECTOR IC FOR STEREO POWER AMPLIFIER

DESCRIPTION

UTC **UPC1237** is a semiconductor integrated circuit designed for protecting stereo power amplifiers and loudspeakers.

FEATURES

- * Wide supply voltage range of 25V~60V.
- * Contain a relay driver. (Max. $I_b=80mA$)
- * Work as either latching function or automatic resetting function by using pin 3. (In both overload detection and output offset detection, either function can be selected.)
- * Single power supply.
- * Built-in output offset detection function. Both positive and negative output offset can be detected through pin2.
- * AC voltage can be detected.
- * Time delay function. The time delay from amplifier power ON to relay ON can be freely set by selecting external components.
- * The moment that amplifier-power is turned off, it can make relay broken OFF and then loudspeaker disconnected for amplifier to prevent a shock off noise.

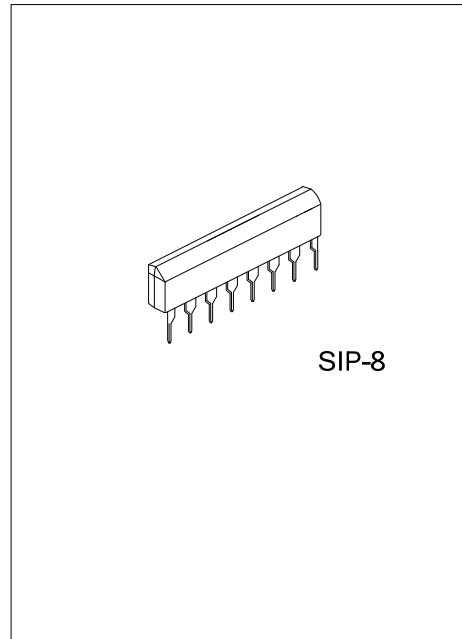

ORDERING INFORMATION

Ordering Number		Package	Packing
Lead Free	Halogen Free		
UPC1237L-G08-T	UPC1237G-G08-T	SIP-8	Tube

<p>UPC1237L-G08-T</p> <p>(1)Packing Type (2)Package Type (3)Lead Free</p>	<p>(1) T: Tube (2) G08: SIP-8 (3) G: Halogen Free, L: Lead Free</p>
---	---

■ PIN CONFIGURATION

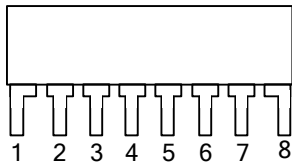

■ PIN DESCRIPTION

PIN NO.	PIN NAME	DESCRIPTION
1	PIN1	Input pin of overload detector
2	PIN2	Input pin of output offset detector
3	PIN3	Input pin of switch for latch/automatic-reset
4	PIN4	Input pin of AC-OFF detector
5	PIN5	GND
6	PIN6	Output pin of relay driver
7	PIN7	Input pin of V _{CC} ON mute, setting delay time
8	PIN8	V _{CC}

■ BLOCK DIAGRAM

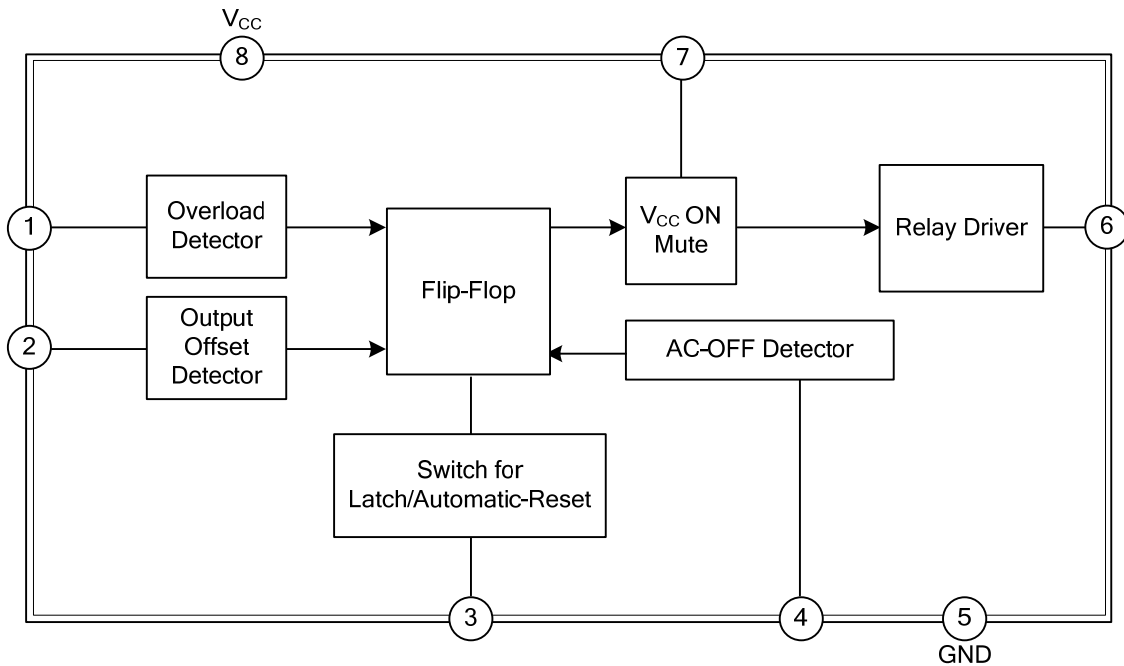

■ ABSOLUTE MAXIMUM RATING ($T_A=25^\circ\text{C}$)

PARAMETER	SYMBOL	RATINGS	UNIT
Power Supply Voltage	V_{CC}	60	V
Pin 4 Maximum Voltage	$V_{4(\text{MAX})}$	10	V
Pin 7 Maximum Voltage	$V_{7(\text{MAX})}$	8	V
Pin 8 Maximum Voltage	$V_{8(\text{MAX})}$	8	V
Pin 1 Maximum Current	$I_{1(\text{MAX})}$	3	mA
Pin 2 Maximum Current	$I_{2(\text{MAX})}$	± 3	mA
Pin 6 Maximum Current	$I_{6(\text{MAX})}$	80	mA
Power Dissipation ($T_A=75^\circ\text{C}$)	P_D	320	mW
Operational Temperature	T_{OPR}	-20 ~ +75	$^\circ\text{C}$
Storage Temperature	T_{STG}	-40 ~ +125	$^\circ\text{C}$

Note: Absolute maximum ratings are those values beyond which the device could be permanently damaged. Absolute maximum ratings are stress ratings only and functional device operation is not implied.

■ RECOMMENDED OPERATING CONDITION

PARAMETER	SYMBOL	RATINGS	UNIT
Supply Voltage	V_{CC}	25 ~ 60	V

■ ELECTRICAL CHARACTERISTICS ($V_{CC}=45\text{V}$, $T_A=25^\circ\text{C}$, Using latching function)

PARAMETER	SYMBOL	TEST CONDITIONS	MIN	TYP	MAX	UNIT
Pin 1 Threshold Voltage	$V_{\text{TH } 1}$	Level to invert at Pin 6	0.58	0.67	0.76	V
Pin 2 Positive Threshold Voltage	$V_{\text{TH } +2}$	Level to invert at Pin 6	0.54	0.62	0.70	V
Pin 2 Negative Threshold Voltage	$V_{\text{TH } -2}$	Level to invert at Pin 6	-0.12	-0.17	-0.23	V
Pin 4 Threshold Voltage	$V_{\text{TH } 4}$	Level to invert at Pin 6	0.60	0.74	0.90	V
Pin 8 Reference Voltage	V_8	$R_L=1.5\text{k}\Omega$	3.0	3.4	3.8	V

■ TEST CIRCUIT

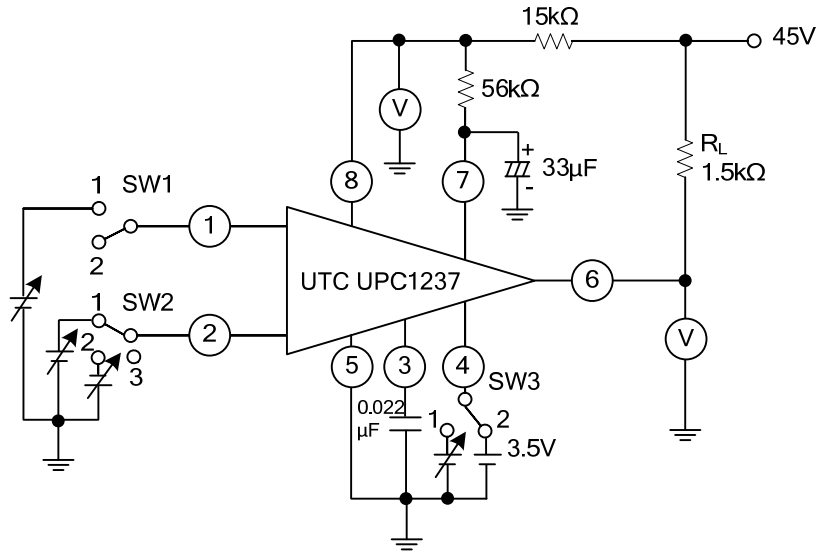

Switch positions

Item	SW 1	SW 2	SW3
$V_{TH} 1$	1	3	2
$V_{TH} +2$	2	1	2
$V_{TH} -2$	2	2	2
$V_{TH} 4$	2	3	1
V8	2	3	2

■ TYPICAL APPLICATION CIRCUIT

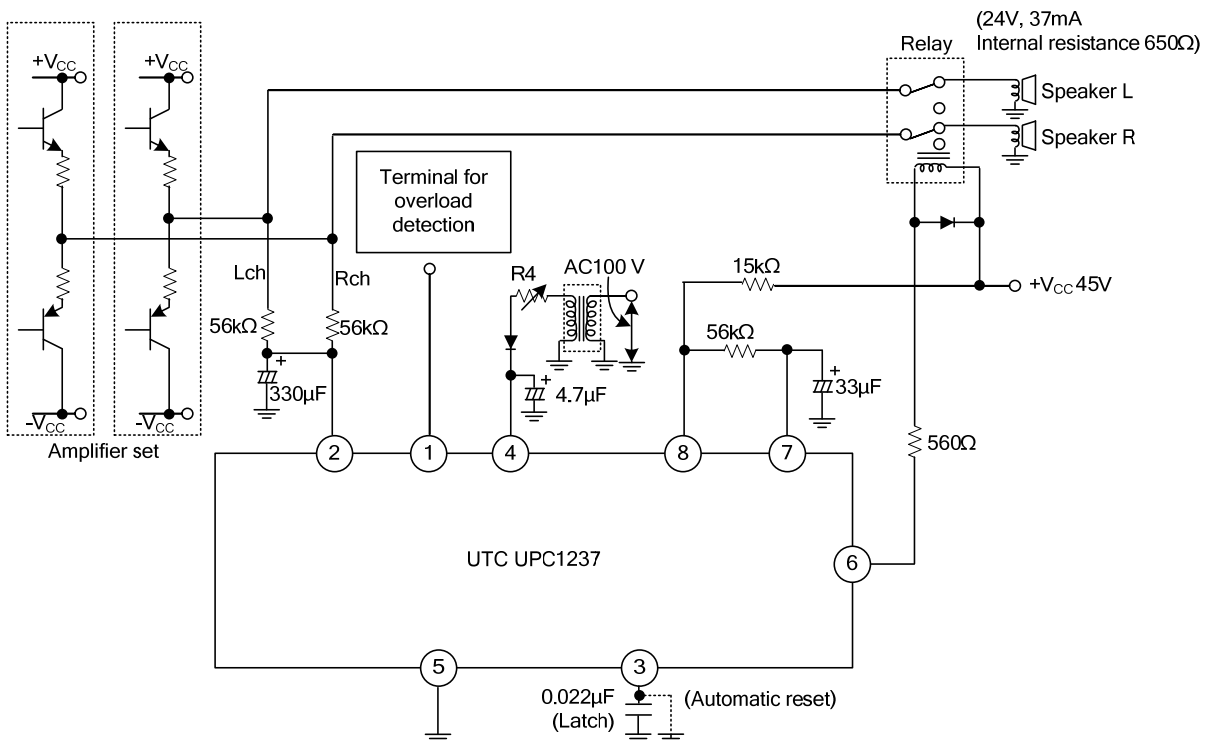

UTC assumes no responsibility for equipment failures that result from using products at values that exceed, even momentarily, rated values (such as maximum ratings, operating condition ranges, or other parameters) listed in products specifications of any and all UTC products described or contained herein. UTC products are not designed for use in life support appliances, devices or systems where malfunction of these products can be reasonably expected to result in personal injury. Reproduction in whole or in part is prohibited without the prior written consent of the copyright owner. The information presented in this document does not form part of any quotation or contract, is believed to be accurate and reliable and may be changed without notice.