

TO-92 Plastic-Encapsulate MOSFETS

< A7000 MOSFET (N-Channel)

$V_{(BR)DSS}$	$R_{DS(on)MAX}$	I_D
60V	5Ω@10V	200mA
	6Ω@4.5V	

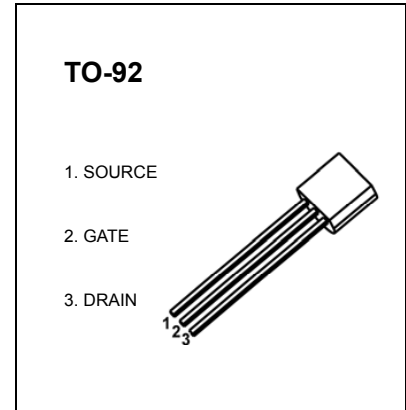

FEATURE

- High density cell design for low $R_{DS(ON)}$
- Voltage controlled small signal switch
- Rugged and reliable
- High saturation current capability

APPLICATION

- Load Switch for Portable Devices
- DC/DC Converter

MARKING

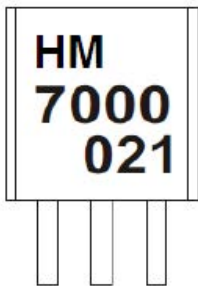

Equivalent Circuit

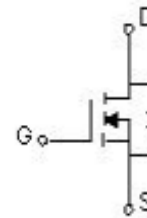

MAXIMUM RATINGS ($T_a=25^{\circ}C$ unless otherwise noted)

Parameter	Symbol	Value	Unit
Drain-Source Voltage	V_{DS}	60	V
Continuous Drain Current	I_D	0.2	A
Power Dissipation	P_D	0.625	W
Thermal Resistance from Junction to Ambient	$R_{\theta JA}$	200	$^{\circ}C/W$
Junction Temperature	T_J	150	$^{\circ}C$
Storage Temperature	T_{stg}	-55 ~ +150	

MOSFET ELECTRICAL CHARACTERISTICS

$T_a=25\text{ }^\circ\text{C}$ unless otherwise specified

Parameter	Symbol	Test conditions	Min	Typ	Max	Unit
Drain-Source Breakdown Voltage	$V_{(BR)DSS}$	$V_{GS}=0\text{ V}, I_D=10\mu\text{A}$	60			V
Gate-Threshold Voltage*	$V_{(GS)th}$	$V_{DS}=V_{GS}, I_D=1\text{mA}$	0.8		3	
Gate-body Leakage	I_{GSS}	$V_{DS}=0\text{ V}, V_{GS}=\pm 15\text{ V}$			± 10	nA
Zero Gate Voltage Drain Current	I_{DSS}	$V_{DS}=60\text{ V}, V_{GS}=0\text{ V}$			1	μA
On-state Drain Current	$I_{D(ON)}$	$V_{GS}=4.5\text{ V}, V_{DS}=10\text{ V}$	75			mA
Drain-Source On-Resistance*	$R_{DS(on)}$	$V_{GS}=4.5\text{V}, I_D=75\text{mA}$			6	Ω
		$V_{GS}=10\text{V}, I_D=500\text{mA}$			5	
Forward Trans conductance*	g_{fs}	$V_{DS}=10\text{ V}, I_D=200\text{mA}$	100			ms
Drain-source on-voltage*	$V_{DS(on)}$	$V_{GS}=10\text{V}, I_D=500\text{mA}$			2.5	V
		$V_{GS}=4.5\text{V}, I_D=75\text{mA}$			0.45	V
Input Capacitance **	C_{iss}	$V_{DS}=25\text{V}, V_{GS}=0\text{V}, f=1\text{MHz}$			60	pF
Output Capacitance **	C_{oss}				25	
Reverse Transfer Capacitance **	C_{rss}				5	
Turn-on Time **	$t_{d(on)}$	$V_{DD}=15\text{ V}, R_L=30\Omega$ $I_D=500\text{mA}, V_{GEN}=10\text{ V}$			10	ns
Turn-off Time **	$t_{d(off)}$	$R_G=25\Omega$			10	

*Pulse test

**These parameters have no way to verify.

Typical Characteristics

Output Characteristics

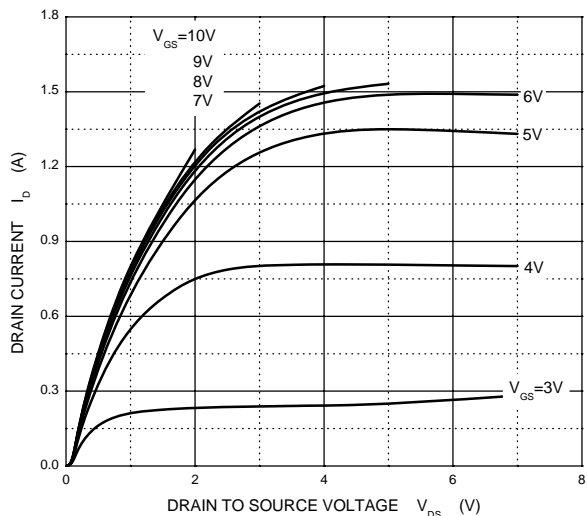

Transfer Characteristics

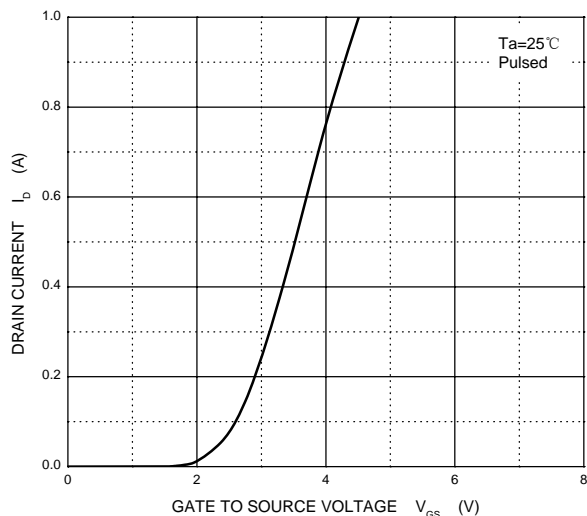

$R_{DS(ON)}$ — I_D

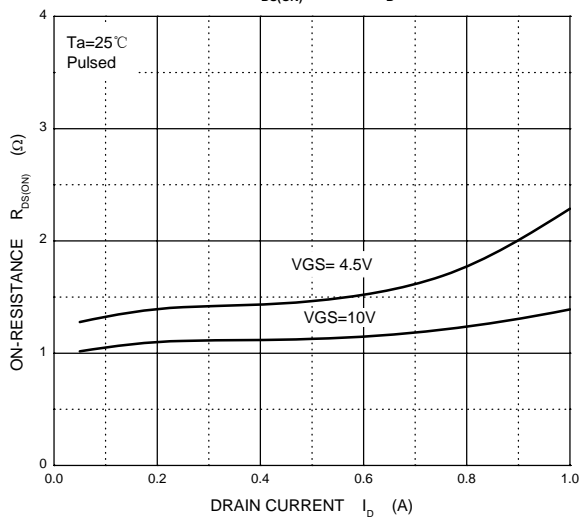

$R_{DS(ON)}$ — V_{GS}

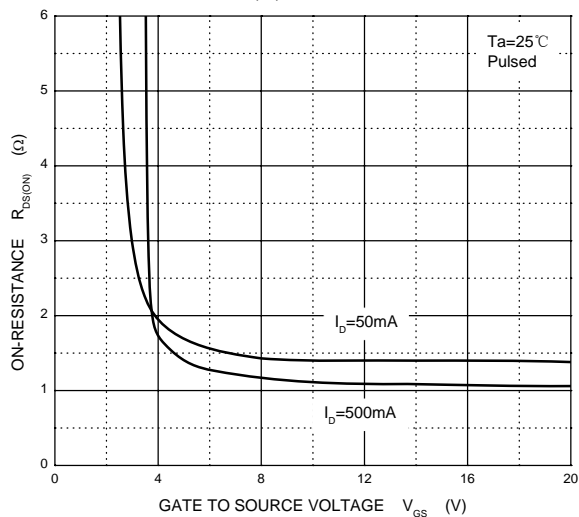

I_S — V_{SD}

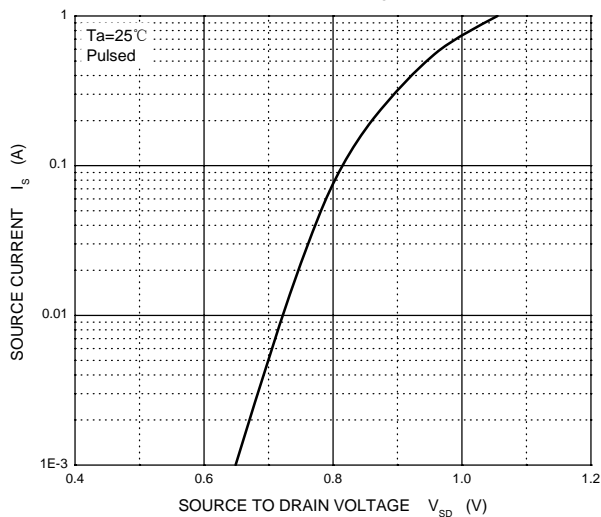

TO-92 Package Outline Dimensions

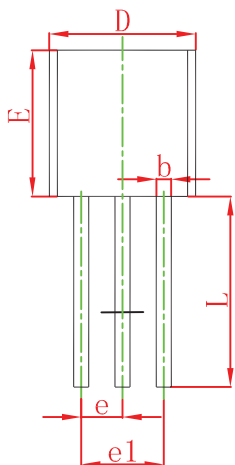
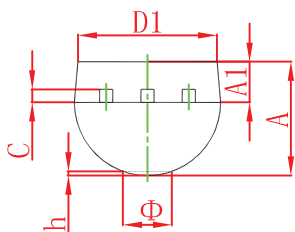

Symbol	Dimensions In Millimeters		Dimensions In Inches	
	Min.	Max.	Min.	Max.
A	3.400	3.600	0.134	0.142
A1	1.150	1.350	0.045	0.053
b	0.380	0.550	0.015	0.022
c	0.410	0.510	0.016	0.020
D	4.400	4.600	0.173	0.181
D1	3.430		0.135	
E	4.400	4.600	0.173	0.181
e	1.270 TYP.		0.050 TYP.	
e1	2.440	2.640	0.096	0.104
L	14.100	14.500	0.555	0.571
Φ		1.600		0.063
h	0.000	0.380	0.000	0.015

TO-92 Suggested Pad Layout

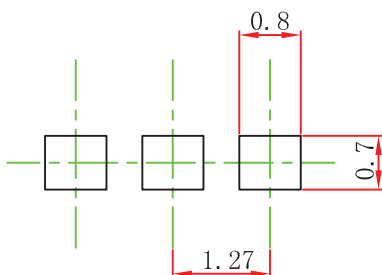

Note:

1. Controlling dimension: in millimeters.
2. General tolerance: $\pm 0.05\text{mm}$.
3. The pad layout is for reference purposes only.

TO-92 PACKAGE TAPEING DIMENSION

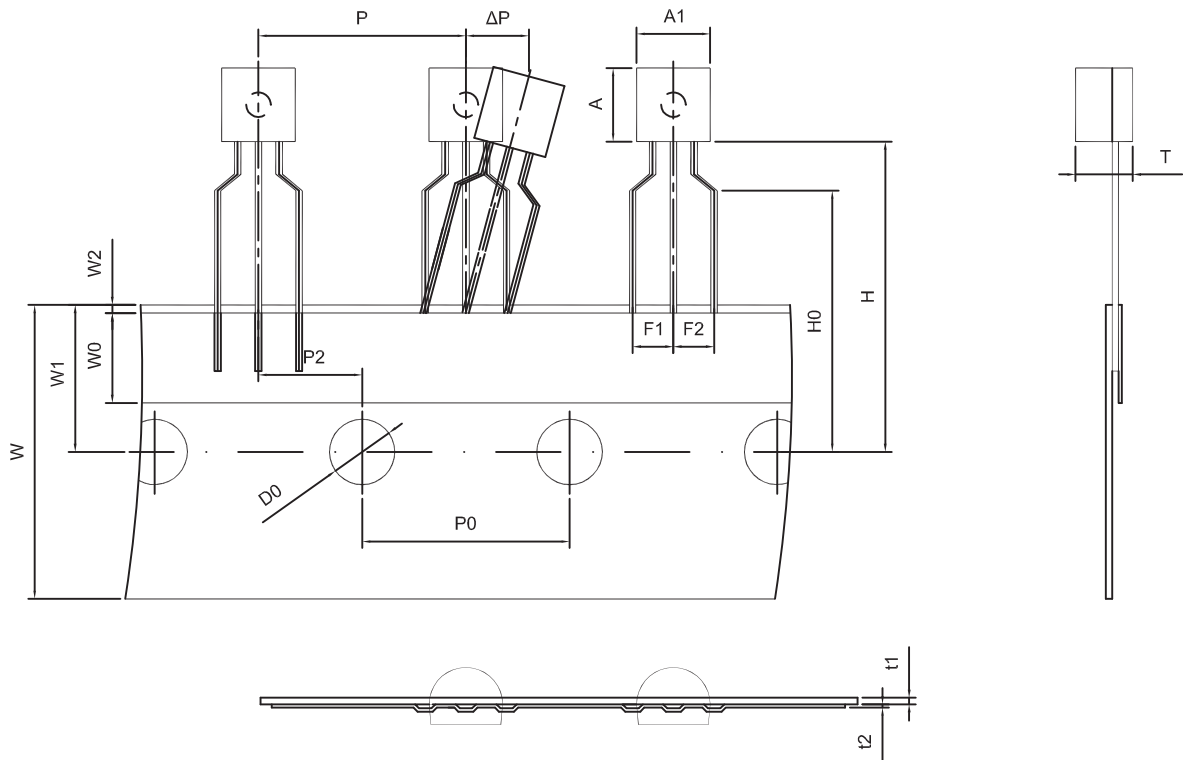

Dimensions are in millimeter

A1	A	T	P	P0	P2	F1	F2	W
4.5±0.1	4.5±0.1	3.5±0.1	12.7±0.3	12.7±0.2	6.35±0.3	2.5±0.3	2.5±0.3	18.0+1.0/-0.5
W0	W1	W2	H	H0	D0	t1	t2	ΔP
6.0±0.5	9.0±0.5	1.0 MAX.	19.0±1.0	16.0±0.5	4.0±0.5	0.4±0.05	0.2±0.05	0 ± 1.0

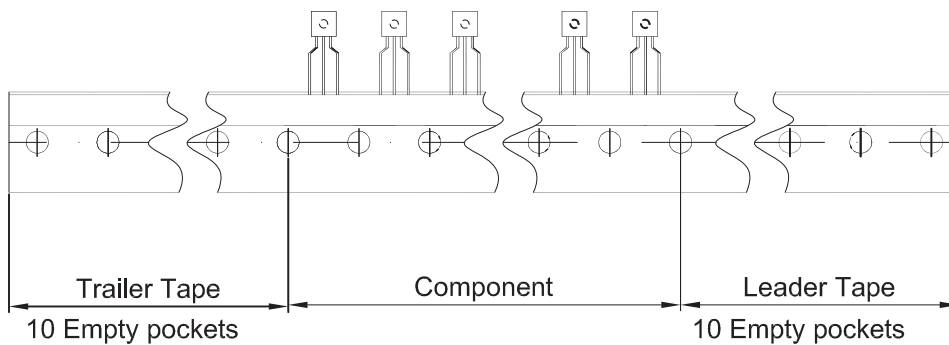

Package	Box	Box Size(mm)	Carton	Carton Size(mm)
TO-92	2000 pcs	333×162×43	20,000 pcs	350×340×250