



TIP32C

PNP SILICON TRANSISTOR

PNP EXPITAXIAL PLANAR TRANSISTOR

■ DESCRIPTION

The UTC **TIP32C** is a PNP epitaxial planar transistor, designed for using in general purpose amplifier and switching applications.

■ FEATURES

* Complement to TIP31C

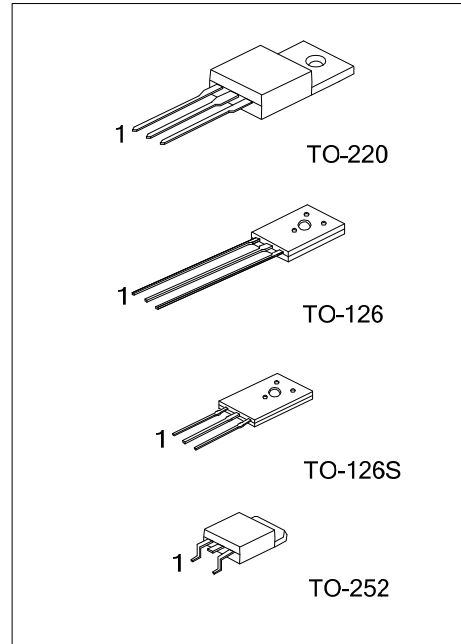

■ ORDERING INFORMATION

Ordering Number		Package	Pin Assignment			Packing
Lead Free	Halogen Free		1	2	3	
TIP32CL-TA3-T	TIP32CG-TA3-T	TO-220	B	C	E	Tube
TIP32CL-T60-K	TIP32CG-T60-K	TO-126	B	C	E	Bulk
TIP32CL-T6S-K	TIP32CG-T6S-K	TO-126S	B	C	E	Bulk
TIP32CL-TN3-R	TIP32CG-TN3-R	TO-252	B	C	E	Tape Reel

<p>TIP32CL-TA3-T</p> <p>(1)Packing Type</p> <p>(2)Package Type</p> <p>(3)Lead Plating</p>	<p>(1) T: Tube, B: Bulk, R: Tape Reel</p> <p>(2) TA3: TO-220, T60: TO-126, T6S: TO-126S TN3: TO-252</p> <p>(3) L: Lead Free, G: Halogen Free</p>
---	--

■ ABSOLUTE MAXIMUM RATINGS ($T_A=25^\circ\text{C}$)

PARAMETER	SYMBOL	RATINGS	UNIT
Collector-Base Voltage	V_{CB0}	-100	V
Emitter-Base Voltage	V_{EB0}	-5	V
Collector Current	DC	I_C	-3
	PULSE	I_{CM}	-5
Base Current	I_B	-1	A
Power Dissipation	TO-220	P_D	2
	TO-126S/TO-126		1.25
	TO-252		1
Junction Temperature	T_J	+150	$^\circ\text{C}$
Storage Temperature	T_{STG}	-40 ~ +150	$^\circ\text{C}$

Note: Absolute maximum ratings are those values beyond which the device could be permanently damaged. Absolute maximum ratings are stress ratings only and functional device operation is not implied.

■ ELECTRICAL CHARACTERISTICS ($T_A=25^\circ\text{C}$, unless otherwise specified.)

PARAMETER	SYMBOL	TEST CONDITIONS	MIN	TYP	MAX	UNIT
Collector Emitter Sustaining Voltage (Note)	BV_{CEO}	$I_C=-30\text{mA}, I_B=0$	-100			V
Collector Cutoff Current	I_{CES}	$V_{CE}=-100\text{V}, V_{BE}=0$			-200	μA
Collector Cutoff Current	I_{CEO}	$V_{CE}=-60\text{V}, I_B=0$			-0.3	mA
Emitter Cutoff current	I_{EBO}	$V_{BE}=-5\text{V}, I_C=0$			-1	mA
Collector-Emitter Saturation Voltage (Note)	$V_{CE(SAT)}$	$I_C=-3\text{A}, I_B=-375\text{mA}$			-1.2	V
Base-Emitter On Voltage*	$V_{BE(ON)}$	$I_C=-3\text{A}, V_{CE}=-4\text{A}$			-1.8	V
DC Current Gain (Note)	h_{FE}	$I_C=-1\text{A}, V_{CE}=-4\text{V}$	25			
		$I_C=-3\text{A}, V_{CE}=-4\text{V}$	10		50	
Current Gain Bandwidth Product	f_T	$I_C=-0.5\text{A}, V_{CE}=-10\text{V}, f=1\text{MHz}$	3			MHz

Note: Pulse Test: $PW \leq 300\mu\text{s}$, Duty Cycle $\leq 2\%$

TYPICAL CHARACTERISTICS

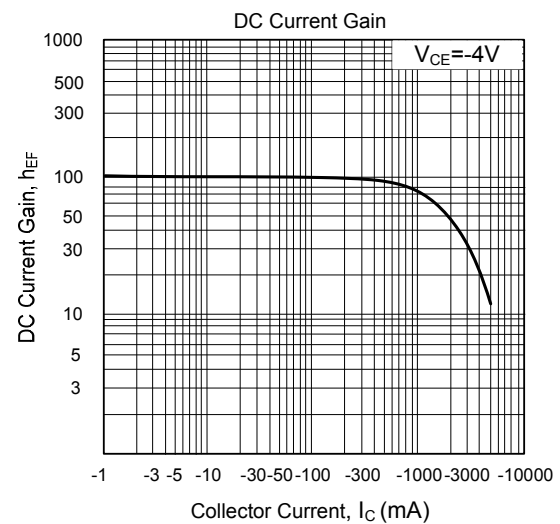
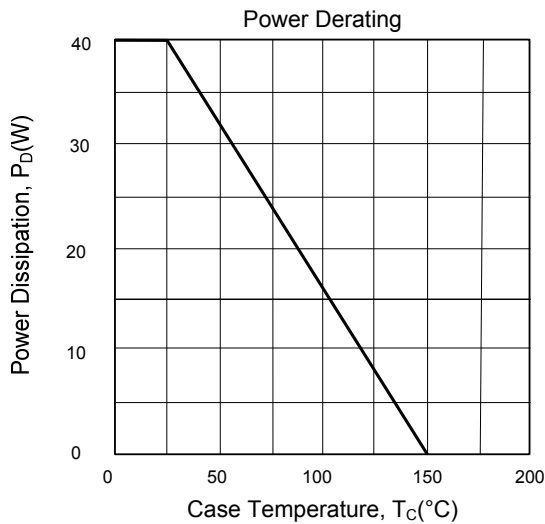
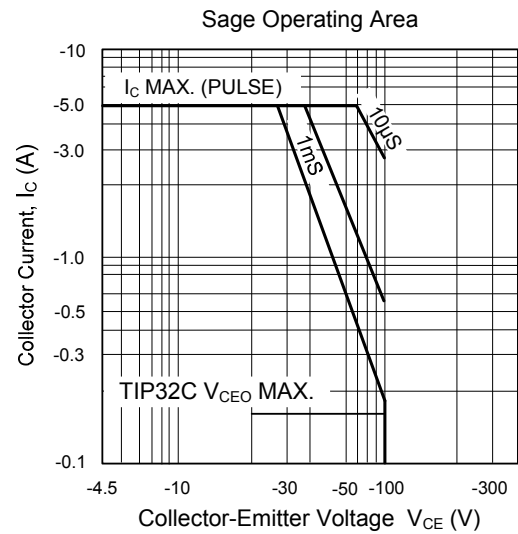
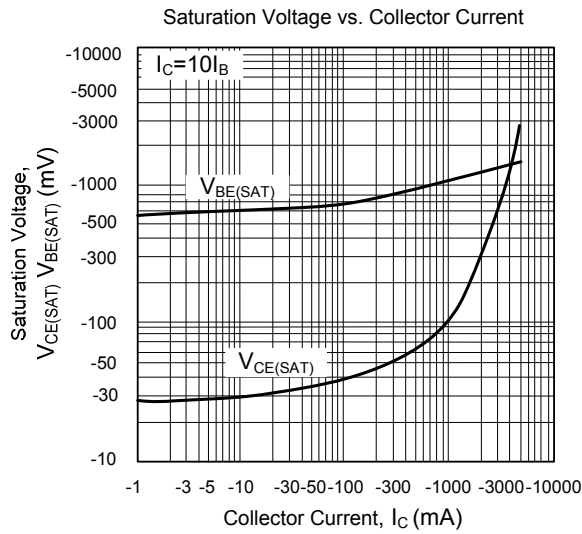

UTC assumes no responsibility for equipment failures that result from using products at values that exceed, even momentarily, rated values (such as maximum ratings, operating condition ranges, or other parameters) listed in products specifications of any and all UTC products described or contained herein. UTC products are not designed for use in life support appliances, devices or systems where malfunction of these products can be reasonably expected to result in personal injury. Reproduction in whole or in part is prohibited without the prior written consent of the copyright owner. The information presented in this document does not form part of any quotation or contract, is believed to be accurate and reliable and may be changed without notice.