



2SB1412

PNP SILICON TRANSISTOR

HIGH VOLTAGE SWITCHING TRANSISTOR

DESCRIPTION

The UTC **2SB1412** is an epitaxial planar type PNP silicon transistor.

FEATURES

- * Excellent DC current gain characteristics
- * Low $V_{CE(SAT)}$
 $V_{CE(SAT)} = -0.35V$ (Typ)
 $(I_C/I_B = -4A/-0.1A)$

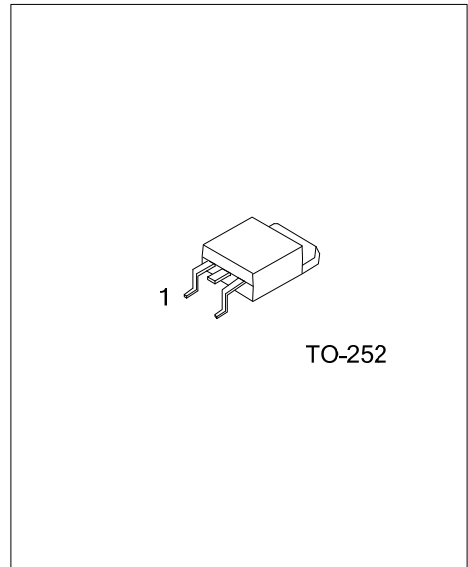

ORDERING INFORMATION

Ordering Number		Package	Pin Assignment			Packing
Lead Free	Halogen Free		1	2	3	
2SB1412L-x-TN3-T	2SB1412G-x-TN3-T	TO-252	B	C	E	Tube
2SB1412L-x-TN3-R	2SB1412G-x-TN3-R	TO-252	B	C	E	Tape Reel

<p>2SB1412L-x-TN3-T</p>	<p>(1) T: Tube, R: Tape Reel</p> <p>(2) TN3: TO-252</p> <p>(3) x: reference to Classification of h_{FE1}</p> <p>(4) L: Lead Free, G: Halogen Free</p>
-------------------------	--

■ ABSOLUTE MAXIMUM RATING ($T_A=25^\circ\text{C}$, unless otherwise specified)

PARAMETER	SYMBOL	RATINGS	UNIT
Collector-Base Voltage	V_{CBO}	-30	V
Collector-Emitter Voltage	V_{CEO}	-20	V
Emitter-Base Voltage	V_{EBO}	-6	V
Collector Current(DC)	I_C	-5	A
Collector Current(PULSE) Single pulse, Pw=10ms	I_{CP}	-10	A
Collector Power Dissipation	P_D	1	W
Collector Power Dissipation ($T_C=25^\circ\text{C}$) (note2)		10	W
Junction Temperature	T_J	+150	$^\circ\text{C}$
Storage Temperature	T_{STG}	-40 ~ +150	$^\circ\text{C}$

Note 1. Absolute maximum ratings are those values beyond which the device could be permanently damaged.

Absolute maximum ratings are stress ratings only and functional device operation is not implied.

2. When mounted on a 40×40×0.7mm ceramic board.

■ ELECTRICAL CHARACTERISTICS ($T_A=25^\circ\text{C}$, unless otherwise specified)

PARAMETER	SYMBOL	TEST CONDITIONS	MIN	TYP	MAX	UNIT
Collector Base Breakdown Voltage	BV_{CBO}	$I_C = -50\mu\text{A}$	-30			V
Collector Emitter Breakdown Voltage	BV_{CEO}	$I_C = -1\text{mA}$	-20			V
Emitter Base Breakdown Voltage	BV_{EBO}	$I_E = -50\mu\text{A}$	-6			V
Collector Cut-Off Current	I_{CBO}	$V_{CB} = -20\text{V}$			-0.5	μA
Emitter Cut-Off Current	I_{EBO}	$V_{EB} = -5\text{V}$			-0.5	μA
DC Current Transfer Ratio	h_{FE}	$V_{CE} = -2\text{V}, I_C = -0.5\text{A}$	82		390	
Collector-Emitter Saturation Voltage	$V_{CE(SAT)}$	$I_C/I_B = -4\text{A}/-0.1\text{A}$			-1.0	V
Transition Frequency	f_T	$V_{CE} = -6\text{V}, I_E = 50\text{mA}, f = 30\text{MHz}$		120		MHz
Output Capacitance	C_{OB}	$V_{CB} = -20\text{V}, I_E = 0\text{A}, f = 1\text{MHz}$		60		pF

■ CLASSIFICATION OF h_{FE}

RANK	P	Q	R
RANGE	82-180	120-270	180-390

TYPICAL CHARACTERISTICS

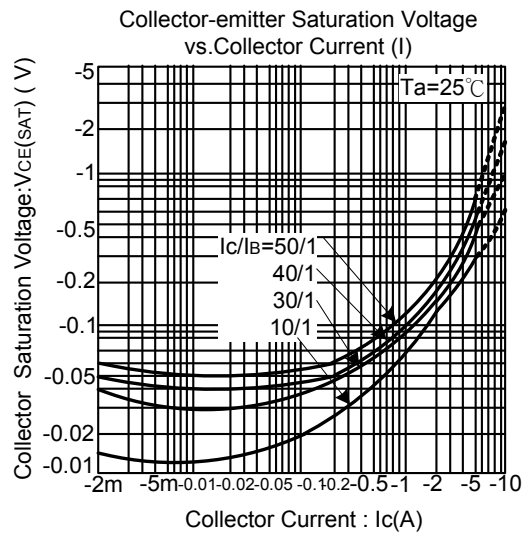
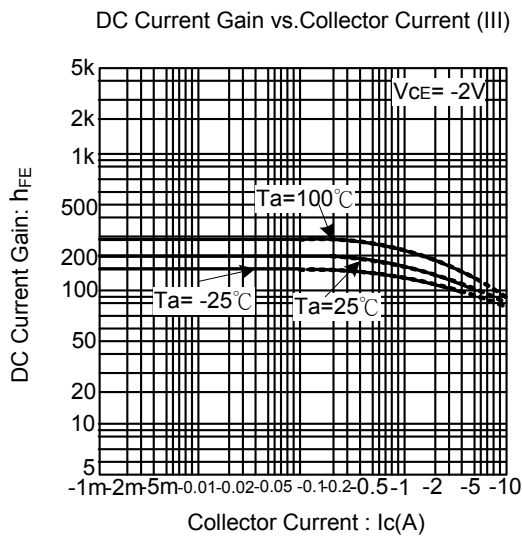
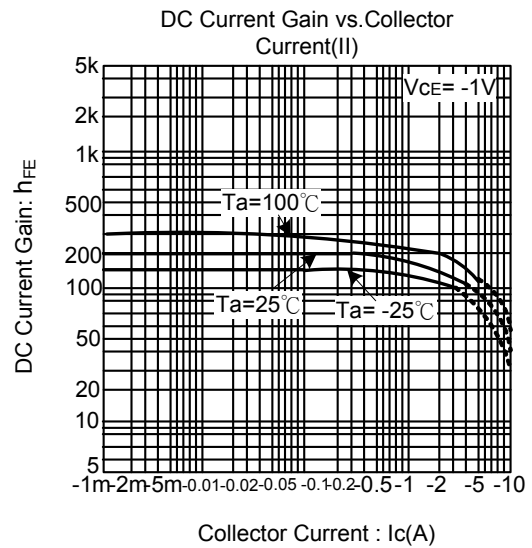
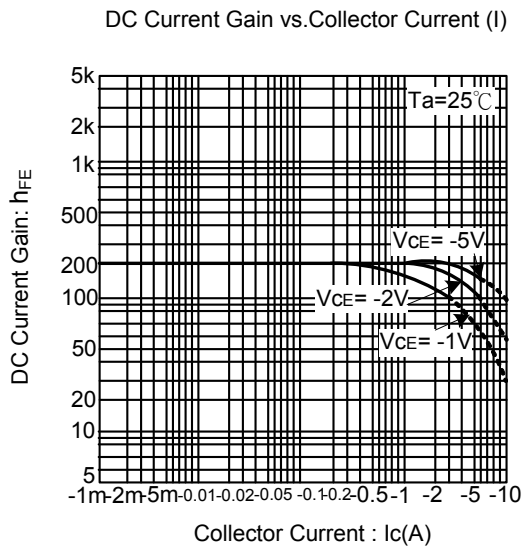
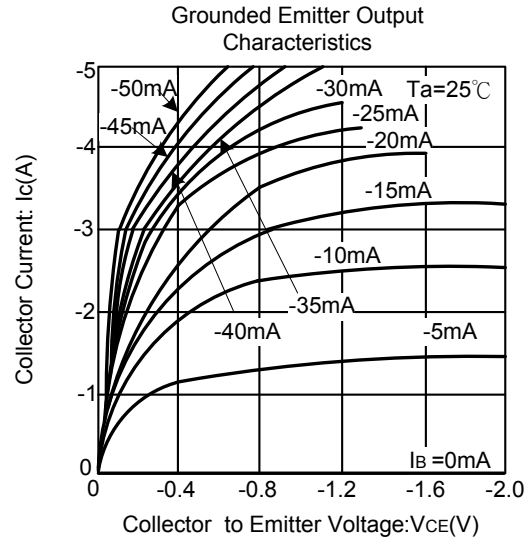
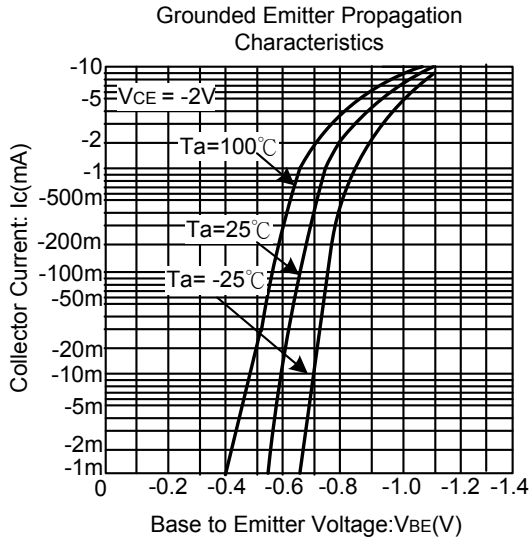

TYPICAL CHARACTERISTICS(Cont.)

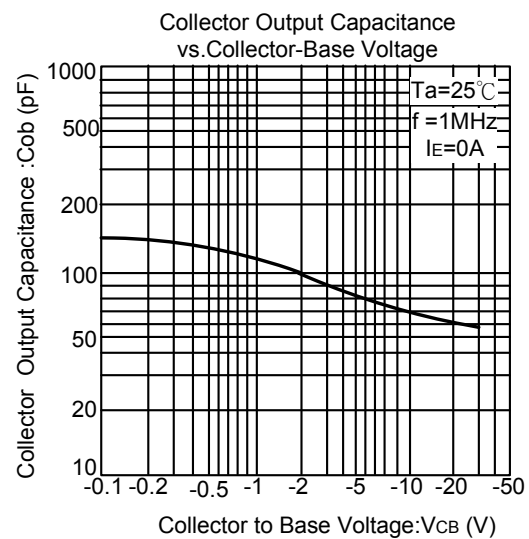
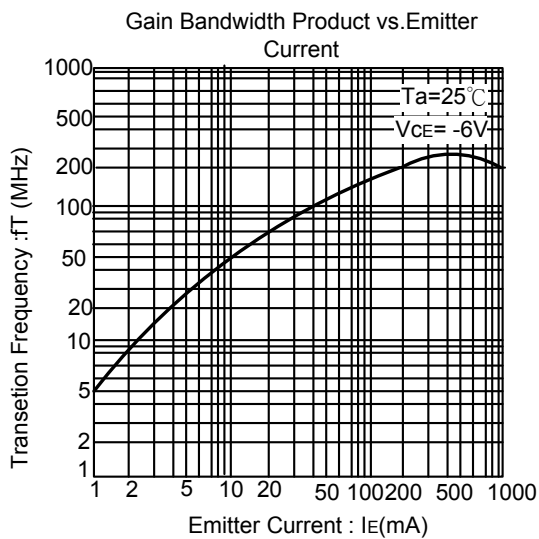
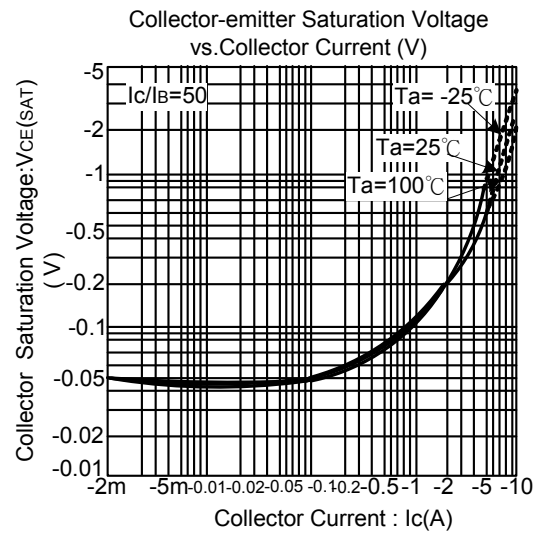
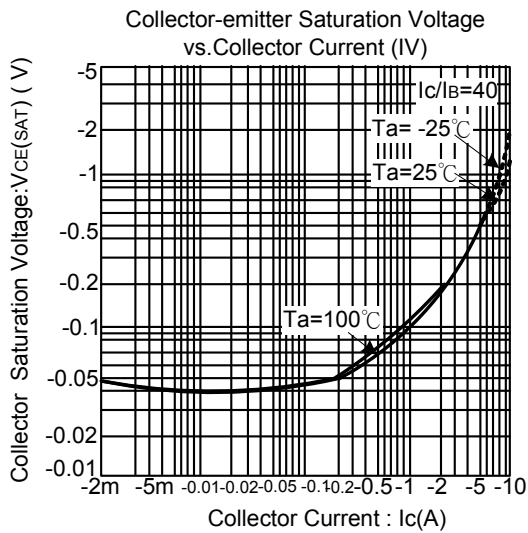
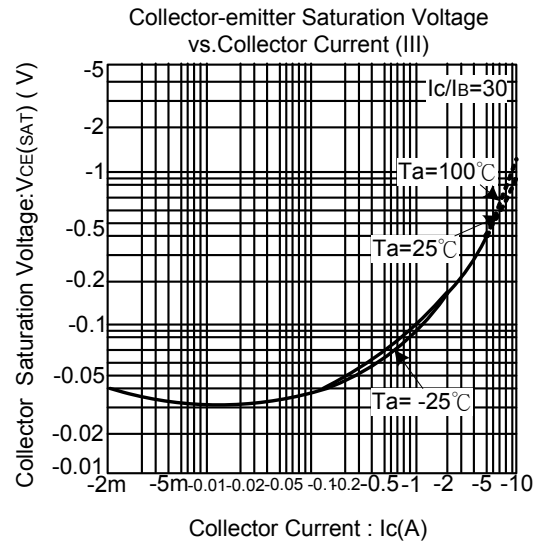
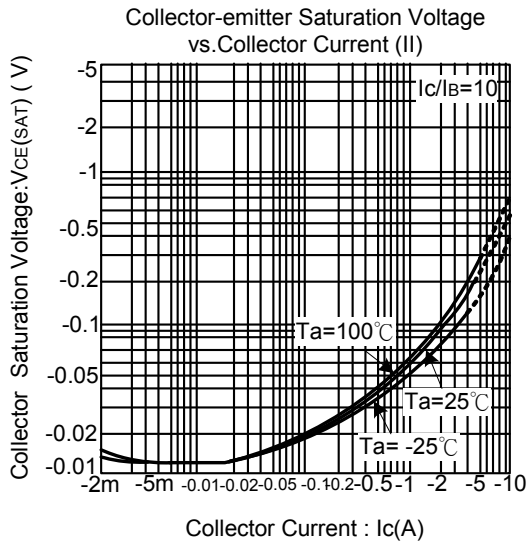

■ TYPICAL CHARACTERISTICS(Cont.)

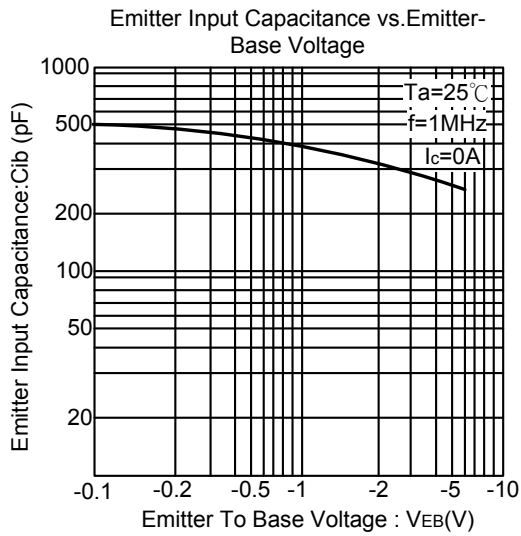

UTC assumes no responsibility for equipment failures that result from using products at values that exceed, even momentarily, rated values (such as maximum ratings, operating condition ranges, or other parameters) listed in products specifications of any and all UTC products described or contained herein. UTC products are not designed for use in life support appliances, devices or systems where malfunction of these products can be reasonably expected to result in personal injury. Reproduction in whole or in part is prohibited without the prior written consent of the copyright owner. The information presented in this document does not form part of any quotation or contract, is believed to be accurate and reliable and may be changed without notice.