



U74LVC1G02

CMOS IC

SINGLE 2-INPUT NOR GATE

DESCRIPTION

The **U74LVC1G02** is a 2-input NOR gate device which provides the Function $Y=A+B$ in positive logic.

This device has power-down protective circuit preventing device from destruction when it is powered down.

FEATURES

- * Operation Voltage Range: 1.6V ~ 5.5V
- * Low Power Current: $I_{CC}=10\mu A$ (Max.)
- * $\pm 24mA$ Output Drive ($V_{CC}=3.0V$)
- * Power Down Protection

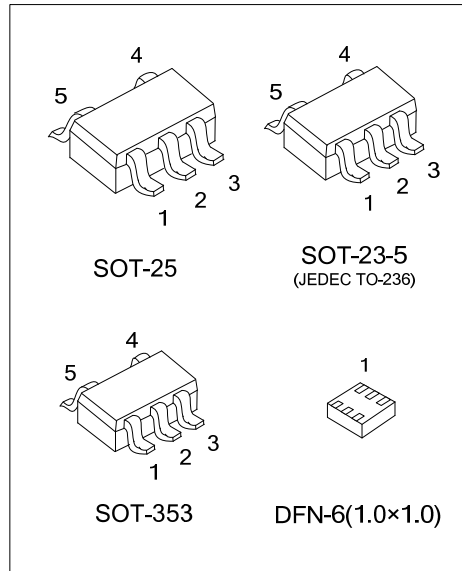

ORDERING INFORMATION

Ordering Number	Package	Packing
U74LVC1G02G-AE5-R	SOT-23-5	Tape Reel
U74LVC1G02G-AF5-R	SOT-25	Tape Reel
U74LVC1G02G-AL5-R	SOT-353	Tape Reel
U74LVC1G02G-K06-1010-R	DFN-6(1.0x1.0)	Tape Reel

<p>U74LVC1G02G-AE5-R</p> <p>(1) Packing Type (2) Package Type (3) Green Package</p>	<p>(1) R: Tape Reel (2) AE5: SOT-23-5, AF5: SOT-25, AL5: SOT-353 K06-1010: DFN-6(1.0x1.0) (3) G: Halogen Free and Lead Free</p>
---	---

MARKING

SOT-23-5 / SOT-25 / SOT-353	DFN-6(1.0x1.0)
<p>3Y2G</p>	<p>Y2</p>

■ PIN CONFIGURATION

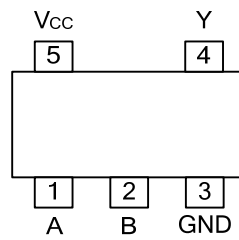

■ FUNCTION TABLE

INPUT(A)	INPUT(B)	OUTPUT(Y)
H	H	L
H	L	L
L	H	L
L	L	H

Note: H: HIGH voltage level; L: LOW voltage level.

■ LOGIC DIAGRAM (positive logic)

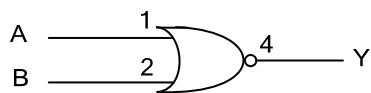

Logic Symbol

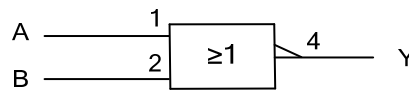

IEC Logic Symbol

■ ABSOLUTE MAXIMUM RATING

PARAMETER	SYMBOL	TEST CONDITIONS	RATINGS	UNIT
Supply Voltage	V_{CC}		-0.5 ~ +6.5	V
Input Voltage	V_{IN}		-0.5 ~ +6.5	V
Output Voltage	V_{OUT}	Output in the high or low state	-0.5 ~ $V_{CC} + 0.5$	V
		Output in the power-off state	-0.5 ~ +6.5	V
Continuous V_{CC} or GND Current	I_{CC}		±100	mA
Continuous Output Current	I_{OUT}	$V_{OUT}=0$ to V_{CC}	±50	mA
Input Clamp Current	I_{IK}	$V_{IN}<0$	-50	mA
Output Clamp Current	I_{OK}	$V_{OUT}<0$	-50	mA
Storage Temperature Range	T_{STG}		-65 ~ +150	°C

Note: Absolute maximum ratings are those values beyond which the device could be permanently damaged. Absolute maximum ratings are stress ratings only and functional device operation is not implied.

■ THERMAL DATA

PARAMETER	SYMBOL	RATINGS	UNIT
Junction to Ambient	SOT-23-5	280	°C/W
	SOT-25	230	°C/W
	SOT-353	350	°C/W

■ RECOMMENDED OPERATING CONDITIONS

PARAMETER	SYMBOL	TEST CONDITIONS	MIN	TYP	MAX	UNIT
Supply Voltage	V_{CC}	Operating	1.65		5.5	V
		Data retention only	1.5			V
Input Voltage	V_{IN}		0		5.5	V
Output Voltage	V_{OUT}	High or low state	0		V_{CC}	V
Input Transition Rise or Fall Rate	$\Delta t/\Delta v$	$V_{CC}=1.8V\pm 0.15V, 2.5V\pm 0.2V$			20	ns/V
		$V_{CC}=3.3V\pm 0.3V$			10	ns/V
		$V_{CC}=5V\pm 0.5V$			5	ns/V
Operating Temperature	T_A		-40		125	°C

■ ELECTRICAL CHARACTERISTICS (T_A =25°C, unless otherwise specified)

PARAMETER	SYMBOL	TEST CONDITIONS	MIN	TYP	MAX	UNIT	
High-Level Input Voltage	V _{IH}	V _{CC} =1.65V ~ 1.95V	0.65×V _{CC}			V	
		V _{CC} =2.3V ~ 2.7V	1.7			V	
		V _{CC} =3V ~ 3.6V	2			V	
		V _{CC} =4.5V ~ 5.5V	0.7×V _{CC}			V	
Low-Level Input Voltage	V _{IL}	V _{CC} =1.65V ~ 1.95V			0.35×V _{CC}	V	
		V _{CC} =2.3V ~ 2.7V			0.7	V	
		V _{CC} =3V ~ 3.6V			0.8	V	
		V _{CC} =4.5V ~ 5.5V			0.3×V _{CC}	V	
High-Level Output Voltage	V _{OH}	V _{CC} =1.65 ~ 5.5V, I _{OH} =-100μA	V _{CC} -0.1			V	
		V _{CC} =1.65V, I _{OH} =-4mA	1.2			V	
		V _{CC} =2.3V, I _{OH} =-8mA	1.9			V	
		V _{CC} =3.0V	I _{OH} =-16mA	2.4			V
			I _{OH} =-24mA	2.3			V
V _{CC} =4.5V, I _{OH} =-32mA	3.8			V			
Low-Level Output Voltage	V _{OL}	V _{CC} =1.65 ~ 5.5V, I _{OL} =100μA			0.1	V	
		V _{CC} =1.65V, I _{OL} =4mA			0.45	V	
		V _{CC} =2.3V, I _{OL} =8mA			0.3	V	
		V _{CC} =3.0V	I _{OL} =16mA			0.4	V
			I _{OL} =24mA			0.55	V
V _{CC} =4.5V, I _{OH} =32mA				0.55	V		
Input Leakage Current	I _{I(LEAK)}	V _{CC} =0 ~ 5.5V, V _{IN} =5.5V or GND			±5	μA	
Power OFF Leakage Current	I _{OFF}	V _{CC} =0V, V _{IN} or V _{OUT} =5.5V			±10	μA	
Quiescent Supply Current	I _Q	V _{CC} =1.65 ~ 5.5V, V _{IN} =V _{CC} or GND, I _{OUT} =0A			10	μA	
Additional Quiescent Supply Current Per Input Pin	ΔI _Q	V _{CC} =3 ~ 5.5V, One input at V _{CC} -0.6V, Other inputs at V _{CC} or GND			500	μA	
Input Capacitance	C _I	V _{CC} =3.3V, V _{IN} =V _{CC} or GND		4		pF	

■ SWITCHING CHARACTERISTICS (T_A =25°C, unless otherwise specified)

PARAMETER	SYMBOL	TEST CONDITIONS	MIN	TYP	MAX	UNIT	
Propagation delay from input (A or B) to output(Y)	t _{PLH} / t _{PHL}	C _L =15pF R _L =1MΩ	V _{CC} =1.8±0.15V	1.9		7.2	ns
			V _{CC} =2.5±0.2V	0.8		4.4	ns
			V _{CC} =3.3±0.3V	0.8		3.6	ns
			V _{CC} =5±0.5V	0.8		3.4	ns
	t _{PLH} / t _{PHL}	C _L =30pF R _L =500Ω	V _{CC} =1.8±0.15V, R _L =1KΩ	2.8		8	ns
			V _{CC} =2.5±0.2V, R _L =500Ω	1.2		5.5	ns
			V _{CC} =3.3±0.3V	1		4.5	ns
			V _{CC} =5±0.5v	1		4	ns

■ OPERATING CHARACTERISTICS (f=10MHz, T_A =25°C, unless otherwise specified)

PARAMETER	SYMBOL	TEST CONDITIONS	MIN	TYP	MAX	UNIT
Power Dissipation Capacitance	C _{PD}	V _{CC} =1.8V		23		pF
		V _{CC} =2.5V		23		pF
		V _{CC} =3.3V		23		pF
		V _{CC} =5.0V		25		pF

■ TEST CIRCUIT AND WAVEFORMS

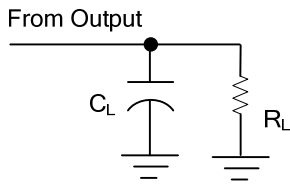

TEST CIRCUIT

V _{CC}	Inputs		V _M	C _L	R _L
	V _{IN}	t _R , t _F			
1.8V±0.15V	V _{CC}	≤2ns	V _{CC} /2	15pF	1MΩ
2.5V±0.2V	V _{CC}	≤2ns	V _{CC} /2	15pF	1MΩ
3.3V±0.3V	3V	≤2.5ns	1.5V	15pF	1MΩ
5V±0.5V	V _{CC}	≤2.5ns	V _{CC} /2	15pF	1MΩ
1.8V±0.15V	V _{CC}	≤2ns	V _{CC} /2	30pF	1KΩ
2.5V±0.2V	V _{CC}	≤2ns	V _{CC} /2	30pF	500Ω
3.3V±0.3V	3V	≤2.5ns	1.5V	50pF	500Ω
5V±0.5V	V _{CC}	≤2.5ns	V _{CC} /2	50pF	500Ω

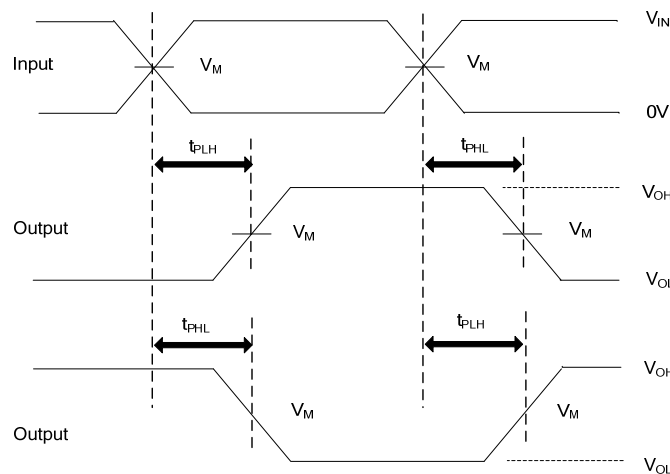

PROPAGATION DELAY TIMES

Note: C_L includes probe and jig capacitance.

All input pulses are supplied by generators having the following characteristics: P_{RR} ≤10MHz, Z_O = 50Ω.

UTC assumes no responsibility for equipment failures that result from using products at values that exceed, even momentarily, rated values (such as maximum ratings, operating condition ranges, or other parameters) listed in products specifications of any and all UTC products described or contained herein. UTC products are not designed for use in life support appliances, devices or systems where malfunction of these products can be reasonably expected to result in personal injury. Reproduction in whole or in part is prohibited without the prior written consent of the copyright owner. The information presented in this document does not form part of any quotation or contract, is believed to be accurate and reliable and may be changed without notice.