



U74HC74

CMOS IC

DUAL D FLIP-FLOP WITH SET AND RESET, POSITIVE-EDGE TRIGGER

DESCRIPTION

The **U74HC74** contains dual D flip-flops and each flip-flop has independent DATA, $\overline{\text{SET}}$, $\overline{\text{RESET}}$ and clock inputs and complementary outputs Q and $\overline{\text{Q}}$. A low level at appropriate input helps $\overline{\text{SET}}$ and $\overline{\text{RESET}}$ adjust the output. Data will be transferred to the output during the low-to-high transition of the CLK while $\overline{\text{SET}}$ and $\overline{\text{RESET}}$ are high.

FEATURES

- * Operation Voltage Range: 2~6V
- * Buffered Inputs
- * Asynchronous Set and Reset
- * Complementary Outputs
- * High Noise Immunity

ORDERING INFORMATION

Ordering Number	Package	Packing
U74HC74G-P14-R	TSSOP-14	Tape Reel
U74HC74G-S14-R	SOP-14	Tape Reel

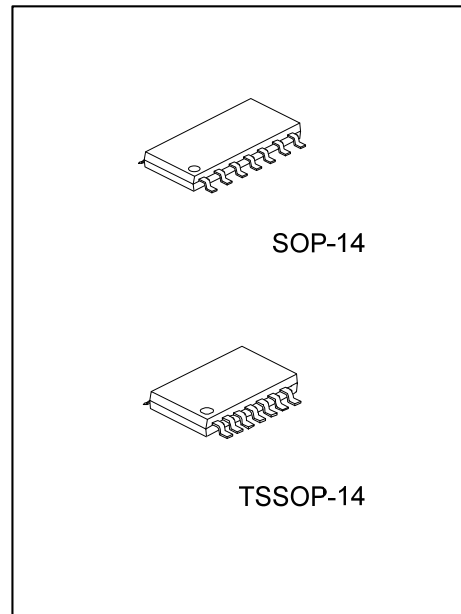

U74HC74G-P14-R	(1) Packing Type	(1) R: Tape Reel
	(2) Package Type	(2) P14: TSSOP-14, S14: SOP-14
	(3) Halogen Free	(3) G: Halogen Free

■ PIN CONFIGURATION

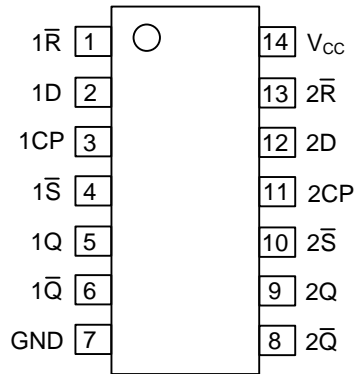

■ FUNCTION TABLE (each gate)

INPUT			OUTPUT		
SET	RESET	CP	D	Q	Q-bar
L	H	x	x	H	L
H	L	x	x	L	H
H	H	↑	H	H	L
H	H	↑	L	L	H
H	H	L	x	Q0	Q0-bar
L	L	x	x	H (note)	H (note)

Note: Unstable state, it will not persist when set and reset inputs return to their inactive level.

■ FUNCTIONAL DIAGRAM

Logic Diagram

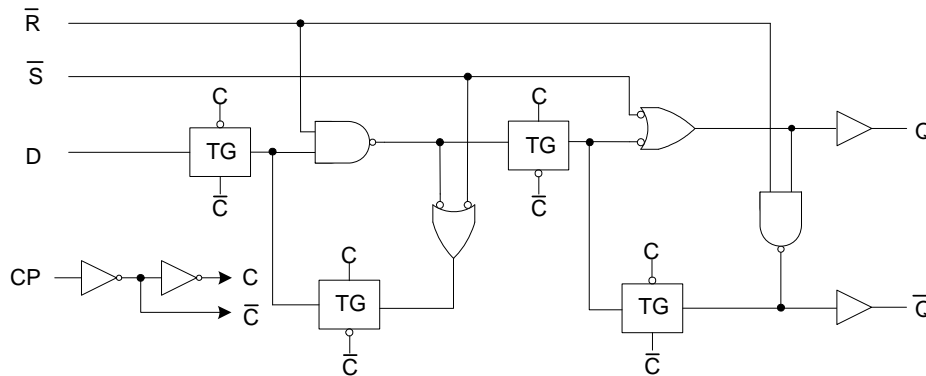

IEC logic symbol

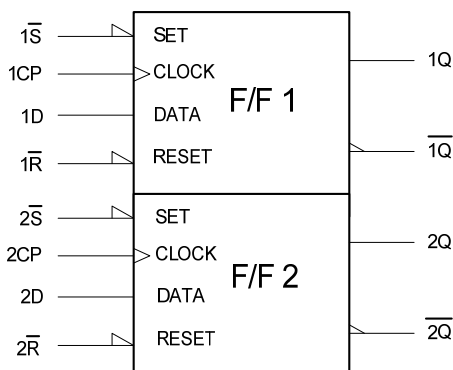

■ ABSOLUTE MAXIMUM RATING (unless otherwise specified)(Note 1)

PARAMETER	SYMBOL	RATINGS	UNIT
Supply Voltage	V_{CC}	-0.5 ~ +7	V
Input Voltage	V_{IN}	0 ~ V_{CC}	V
Output Voltage	V_{OUT}	0 ~ V_{CC}	V
Input Clamp Current	I_{IK}	±20	mA
Output Clamp Current	I_{OK}	±20	mA
Output Current	I_{OUT}	±25	mA
V_{CC} or GND Current	I_{CC}	±50	mA
Storage Temperature	T_{STG}	-65 ~ +150	°C

Note: Absolute maximum ratings are those values beyond which the device could be permanently damaged.

Absolute maximum ratings are stress ratings only and functional device operation is not implied.

■ RECOMMENDED OPERATING CONDITIONS

PARAMETER	SYMBOL	MIN	TYP	MAX	UNIT
Supply Voltage	V_{CC}	2		6	V
Input Voltage	V_{IN}	0		V_{CC}	V
Output Voltage	V_{OUT}	0		V_{CC}	V
Input Transition Rise or Fall Rate	t_R, t_F	$V_{CC}=2V$		1000	ns
		$V_{CC}=4.5V$		500	
		$V_{CC}=6V$		400	
Operating Temperature	T_A	-55		125	°C

■ STATIC CHARACTERISTICS ($T_A=25^\circ\text{C}$)

PARAMETER	SYMBOL	TEST CONDITIONS	MIN	TYP	MAX	UNIT
High-Level Input Voltage	V_{IH}	$V_{CC}=2.0V$	1.5			V
		$V_{CC}=4.5V$	3.15			
		$V_{CC}=6.0V$	4.2			
Low-Level Input Voltage	V_{IL}	$V_{CC}=2.0V$			0.5	V
		$V_{CC}=4.5V$			1.35	
		$V_{CC}=6.0V$			1.8	
High-Level Output Voltage	V_{OH}	$V_{CC}=2.0V, I_{OH}=-20\mu A$	1.9			V
		$V_{CC}=4.5V, I_{OH}=-20\mu A$	4.4			
		$V_{CC}=6.0V, I_{OH}=-20\mu A$	5.9			
		$V_{CC}=4.5V, I_{OH}=-4mA$	3.98			
		$V_{CC}=6V, I_{OH}=-5.2mA$	5.48			
Low-Level Output Voltage	V_{OL}	$V_{CC}=2.0V, I_{OL}=20\mu A$			0.1	V
		$V_{CC}=4.5V, I_{OL}=20\mu A$			0.1	
		$V_{CC}=6.0V, I_{OL}=20\mu A$			0.1	
		$V_{CC}=4.5, I_{OL}=4mA$			0.26	
		$V_{CC}=6, I_{OL}=5.2mA$			0.26	
Input Leakage Current	$I_{I(LEAK)}$	$V_{CC}=6.0V, V_{IN}=V_{CC}$ or GND			±0.1	μA
Quiescent Supply Current	I_Q	$V_{CC}=6.0V, V_{IN}=V_{CC}$ or GND, $I_{OUT}=0$			4	μA
Input Capacitance	C_{IN}	$V_{CC}=6.0V, V_{IN}=V_{CC}$ or GND			10	pF

■ DYNAMIC CHARACTERISTICS($T_a=25^\circ\text{C}$) (Input: $t_R, t_F=6\text{ns}$)

PARAMETER	SYMBOL	TEST CONDITIONS	MIN	TYP	MAX	UNIT
Propagation delay from input (CP) to output(Q, \bar{Q})	t_{PLH}/t_{PHL}	$V_{CC}=2.0\text{V}, C_L=50\text{pF}$			175	ns
		$V_{CC}=4.5\text{V}, C_L=50\text{pF}$			35	ns
		$V_{CC}=6.0\text{V}, C_L=50\text{pF}$			30	ns
Propagation delay from input (\bar{R}, \bar{S}) to output(Q, \bar{Q})	t_{PLH}/t_{PHL}	$V_{CC}=2.0\text{V}, C_L=50\text{pF}$			200	ns
		$V_{CC}=4.5\text{V}, C_L=50\text{pF}$			40	ns
		$V_{CC}=6.0\text{V}, C_L=50\text{pF}$			34	ns
Output Transition Time	t_{TLH}/t_{THL}	$V_{CC}=2.0\text{V}, C_L=50\text{pF}$			75	ns
		$V_{CC}=4.5\text{V}, C_L=50\text{pF}$			15	ns
		$V_{CC}=6.0\text{V}, C_L=50\text{pF}$			13	ns
CP frequency	f_{MAX}	$V_{CC}=5\text{V}, C_L=15\text{pF}$		50		MHZ

■ OPERATING CHARACTERISTICS

PARAMETER	SYMBOL	TEST CONDITIONS	MIN	TYP	MAX	UNIT
Power Dissipation Capacitance	Cpd	No load		25		pF

■ TEST CIRCUIT AND WAVEFORMS

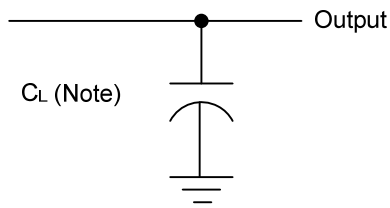

Note : CL includes probe and jig capacitance.

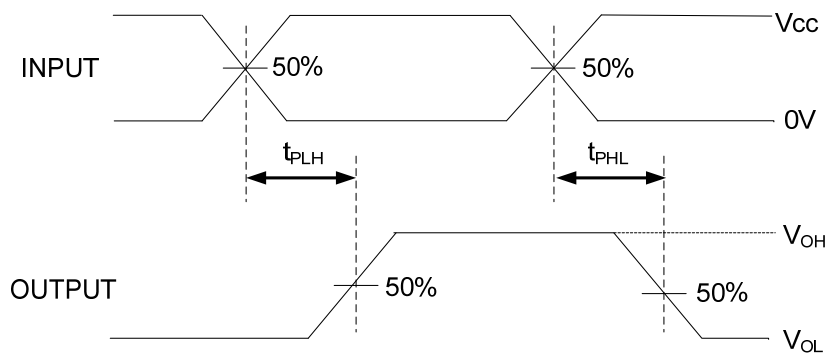

UTC assumes no responsibility for equipment failures that result from using products at values that exceed, even momentarily, rated values (such as maximum ratings, operating condition ranges, or other parameters) listed in products specifications of any and all UTC products described or contained herein. UTC products are not designed for use in life support appliances, devices or systems where malfunction of these products can be reasonably expected to result in personal injury. Reproduction in whole or in part is prohibited without the prior written consent of the copyright owner. The information presented in this document does not form part of any quotation or contract, is believed to be accurate and reliable and may be changed without notice.