

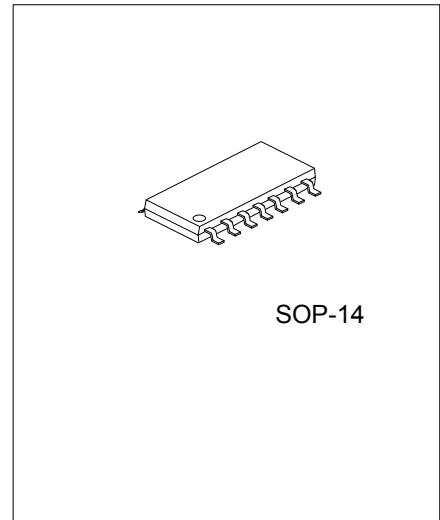

U74AHC125

CMOS IC

QUADRUPLE BUS BUFFER GATE WITH 3-STATE OUTPUTS



DESCRIPTION

The **U74AHC125** is a quadruple bus buffer gate with 3-state output. When \overline{OE} is high, the Y output is in a high-impedance state. When \overline{OE} is low, the device passes non inverted data from the A input to the Y output.

To ensure the high-impedance state during power up or power down, \overline{OE} should be tied to V_{CC} through a pull-up resistor; the minimum value of the resistor is determined by the current-sinking capability of the driver.

FEATURES

- * Wide supply voltage range from 2V to 5.5V
- * Max t_{PD} of 3.8ns from A to Y at 5V, $C_L=15pF$
- * Low Quiescent Current: $I_{CC} = 4 \mu A$ (Max.) at 5.5V
- * ± 8 mA Output Driver at 5V

ORDERING INFORMATION

Ordering Number		Package	Packing
Lead Free	Halogen Free		
U74AHC125L-S14-R	U74AHC125G-S14-R	SOP-14	Tape Reel
U74AHC125L-S14-T	U74AHC125G-S14-T	SOP-14	Tube

<p>U74AHC125L-S14-T</p> <p>(1)Packing Type (2)Package Type (3)Lead Free</p>	<p>(1) R: Tape Reel, T: Tube (2) S14: SOP-14 (3) G: Halogen Free, L: Lead Free</p>
---	--

■ PIN CONFIGURATION

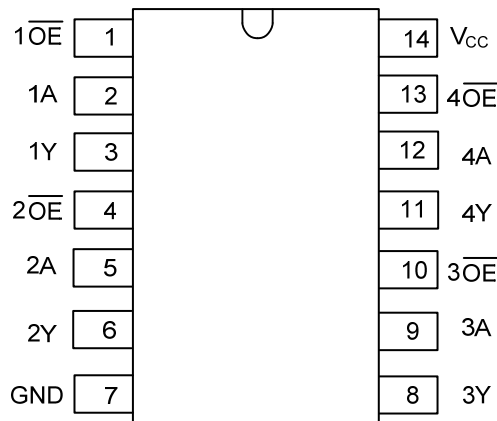

■ FUNCTION TABLE

INPUTS		OUTPUTS
\overline{OE}	A	Y
L	H	H
L	L	L
H	X	Z

■ LOGIC DIAGRAM

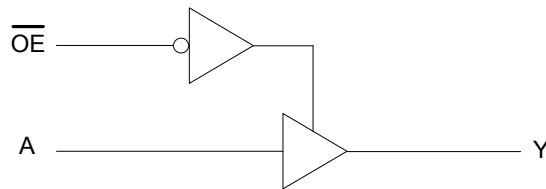

■ ABSOLUTE MAXIMUM RATING (unless otherwise specified)

PARAMETER	SYMBOL	RATINGS	UNIT
Supply Voltage	V_{CC}	-0.5~7	V
Input Voltage	V_{IN}	-0.5~7	V
Output Voltage	V_{OUT}	-0.5~ V_{CC} +0.5	V
Input Clamp Current ($V_{IN}<0$)	I_{IK}	-20	mA
Output Clamp Current ($V_{OUT}<0$, or $V_{OUT}>V_{CC}$)	I_{OK}	± 20	mA
Output Current	I_{OUT}	± 25	mA
V_{CC} or GND Current	I_{CC}	± 50	mA
Storage Temperature	T_{STG}	-65 ~ +150	$^{\circ}C$

Note: 1. The input and output voltage ratings may be exceeded if the input and output current ratings are observed.
 2. Absolute maximum ratings are those values beyond which the device could be permanently damaged.
 Absolute maximum ratings are stress ratings only and functional device operation is not implied.

■ RECOMMENDED OPERATING COMDITIONS

PARAMETER	SYMBOL	TEST CONDITIONS	MIN	TYP	MAX	UNIT
Supply Voltage	V_{CC}		2		5.5	V
High-Level Input Voltage	V_{IH}	$V_{CC} = 2V$	1.5			V
		$V_{CC} = 3V$	2.1			
		$V_{CC} = 5.5V$	3.85			
Low-Level Input Voltage	V_{IL}	$V_{CC} = 2V$			0.5	V
		$V_{CC} = 3V$			0.9	
		$V_{CC} = 5.5V$			1.65	
Input Voltage	V_{IN}		0		5.5	V
Output Voltage	V_{OUT}		0		V_{CC}	V
High-level Output Current	I_{OH}	$V_{CC} = 2V$			-50	μA
		$V_{CC} = 3.3\pm 0.3V$			-4	mA
		$V_{CC} = 5\pm 0.5V$			-8	
Low-level Output Current	I_{OL}	$V_{CC} = 2V$			50	μA
		$V_{CC} = 3.3\pm 0.3V$			4	mA
		$V_{CC} = 5\pm 0.5V$			8	
Input Transition Rise or Fall Rate	$\Delta t/\Delta V$	$V_{CC} = 3.3\pm 0.3V$			100	ns/V
		$V_{CC} = 5\pm 0.5V$			20	
Operating Temperature	T_A		-40		85	$^{\circ}C$

■ ELECTRICAL CHARACTERISTICS (T_A =25°C , unless otherwise specified)

PARAMETER	SYMBOL	TEST CONDITIONS	MIN	TYP	MAX	UNIT
High-Level Output Voltage	V _{OH}	I _{OH} = -50 μA, V _{CC} = 2V	1.9	2		V
		I _{OH} = -50 μA, V _{CC} = 3V	2.9	3		
		I _{OH} = -50 μA, V _{CC} = 4.5V	4.4	4.5		
		I _{OH} = -4 mA, V _{CC} = 3V	2.58			
		I _{OH} = -8 mA, V _{CC} = 4.5V	3.94			
Low-Level Output Voltage	V _{OL}	I _{OH} = 50 μA, V _{CC} = 2V			0.1	V
		I _{OH} = 50 μA, V _{CC} = 3V			0.1	
		I _{OH} = 50 μA, V _{CC} = 4.5V			0.1	
		I _{OH} = 4 mA, V _{CC} = 3V			0.36	
		I _{OH} = 8 mA, V _{CC} = 4.5V			0.36	
Input Leakage Current (A or \overline{OE} Input)	I _{I(LEAK)}	V _{IN} = 5.5V or GND, V _{CC} = 0 to 5.5V			±0.1	μA
High-impedance State Current	I _{OZ}	V _{OUT} = V _{CC} or GND, V _{CC} = 5.5V			±0.25	μA
Quiescent Supply Current	I _{CC}	V _{IN} = V _{CC} or GND, I _{OUT} = 0, V _{CC} = 5.5V			4	μA
Input Capacitance	C _{IN}	V _{IN} = V _{CC} or GND, V _{CC} = 5V		4	10	pF

■ SWITCHING CHARACTERISTICS

(V_{CC} = 3.3V ± 0.3V, T_A =25°C)

PARAMETER	SYMBOL	TEST CONDITIONS	MIN	TYP	MAX	UNIT
Propagation Delay from Input A to Output Y, t _{PD}	t _{PLH}	C _L = 15pF, R _L = 1kΩ		5.6	8	ns
		C _L = 50pF, R _L = 1kΩ		8.1	11.5	
	t _{PHL}	C _L = 15pF, R _L = 1kΩ		5.6	8	ns
		C _L = 50pF, R _L = 1kΩ		8.1	11.5	
Propagation Delay from Input \overline{OE} to Output Y, t _{EN}	t _{PZH}	C _L = 15pF, R _L = 1kΩ		5.4	8	ns
		C _L = 50pF, R _L = 1kΩ		7.9	11.5	
	t _{PZL}	C _L = 15pF, R _L = 1kΩ		5.4	8	ns
		C _L = 50pF, R _L = 1kΩ		7.9	11.5	
Propagation Delay from Input \overline{OE} to Output Y, t _{DIS}	t _{PHZ}	C _L = 15pF, R _L = 1kΩ		7	9.7	ns
		C _L = 50pF, R _L = 1kΩ		9.5	13.2	
	t _{PLZ}	C _L = 15pF, R _L = 1kΩ		7	9.7	ns
		C _L = 50pF, R _L = 1kΩ		9.5	13.2	

(V_{CC} = 5V ± 0.5V, T_A =25°C)

PARAMETER	SYMBOL	TEST CONDITIONS	MIN	TYP	MAX	UNIT
Propagation Delay from Input A to Output Y, t _{PD}	t _{PLH}	C _L = 15pF, R _L = 1kΩ		3.8	5.5	ns
		C _L = 50pF, R _L = 1kΩ		5.3	7.5	
	t _{PHL}	C _L = 15pF, R _L = 1kΩ		3.8	5.5	ns
		C _L = 50pF, R _L = 1kΩ		5.3	7.5	
Propagation Delay from Input \overline{OE} to Output Y, t _{EN}	t _{PZH}	C _L = 15pF, R _L = 1kΩ		3.6	5.1	ns
		C _L = 50pF, R _L = 1kΩ		5.1	7.1	
	t _{PZL}	C _L = 15pF, R _L = 1kΩ		3.6	5.1	ns
		C _L = 50pF, R _L = 1kΩ		5.1	7.1	
Propagation Delay from Input \overline{OE} to Output Y, t _{DIS}	t _{PHZ}	C _L = 15pF, R _L = 1kΩ		4.6	6.8	ns
		C _L = 50pF, R _L = 1kΩ		6.1	8.8	
	t _{PLZ}	C _L = 15pF, R _L = 1kΩ		4.6	6.8	ns
		C _L = 50pF, R _L = 1kΩ		6.1	8.8	

■ OPERATING CHARACTERISTICS (T_A =25°C)

PARAMETER	SYMBOL	TEST CONDITIONS	RATINGS	UNIT
Power Dissipation Capacitance	C _{PD}	V _{CC} = 5V, f = 1MHz, No load	14	pF

■ TEST CIRCUIT AND WAVEFORMS

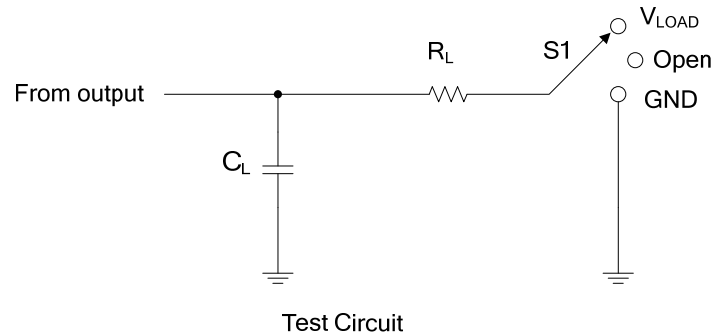

TEST	S1
t_{PLH}/t_{PHL}	Open
t_{PLZ}/t_{PZL}	V_{LOAD}
t_{PHZ}/t_{PZH}	GND

V_{CC}	Input		V_M	V_{LOAD}	C_L	R_L	V_{Δ}
	V_{IN}	t_r, t_f					
$3.3V \pm 0.3V$	V_{CC}	$\leq 3ns$	$V_{CC}/2$	V_{CC}	15pF	1k Ω	0.3V
					50pF		
$5V \pm 0.5V$	V_{CC}	$\leq 3ns$	$V_{CC}/2$	V_{CC}	15pF	1k Ω	0.5V
					50pF		

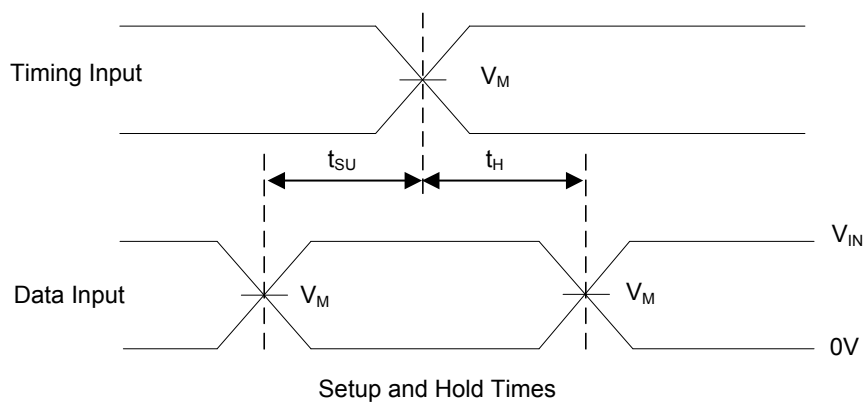
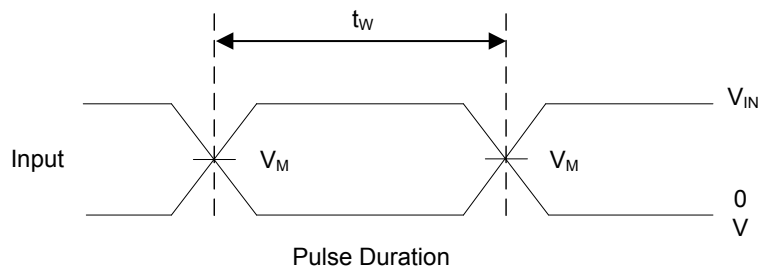

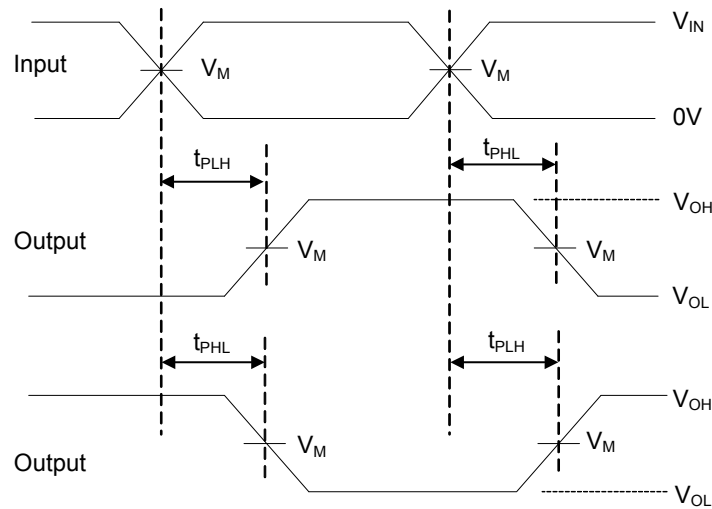

Voltage Waveforms Propagation Delay Times

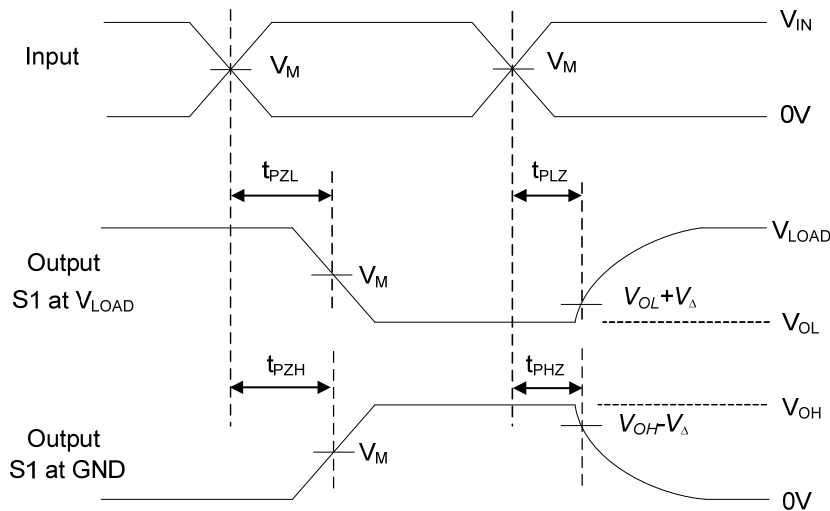

Voltage Waveforms Enable and Disable Times

- Notes: 1. C_L includes probe and jig capacitance.
 2. All input pulses are supplied by generators having the following characteristics: PRR ≤ 1 MHz, $Z_0 = 50\Omega$.

UTC assumes no responsibility for equipment failures that result from using products at values that exceed, even momentarily, rated values (such as maximum ratings, operating condition ranges, or other parameters) listed in products specifications of any and all UTC products described or contained herein. UTC products are not designed for use in life support appliances, devices or systems where malfunction of these products can be reasonably expected to result in personal injury. Reproduction in whole or in part is prohibited without the prior written consent of the copyright owner. The information presented in this document does not form part of any quotation or contract, is believed to be accurate and reliable and may be changed without notice.