



U74HCT3G34

CMOS IC

TRIPLE BUFFER GATE

■ **DESCRIPTION**

The U74HCT3G34 provides three buffers, it is compatible with TTL.

■ **FEATURES**

- * Low power dissipation
- * High speed
- * High noise immunity

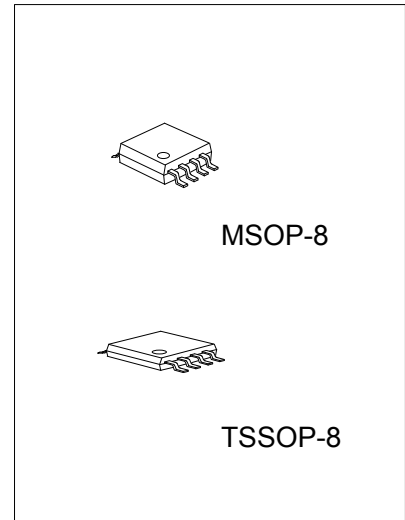

■ **ORDERING INFORMATION**

Ordering Number		Package	Packing
Lead Free	Halogen Free		
U74HCT3G34L-P08-R	U74HCT3G34G-P08-R	TSSOP-8	Tape Reel
U74HCT3G34L-SM1-R	U74HCT3G34G-SM1-R	MSOP-8	Tape Reel

<p>U74HCT3G34L-P08-R</p> <p>(1)Packing Type (2)Package Type (3)Lead Free</p>	<p>(1) R: Tape Reel (2) P08: TSSOP-8, SM1: MSOP-8 (3) G:Halogen Free, L: Lead Free</p>
--	--

■ PIN CONFIGURATION

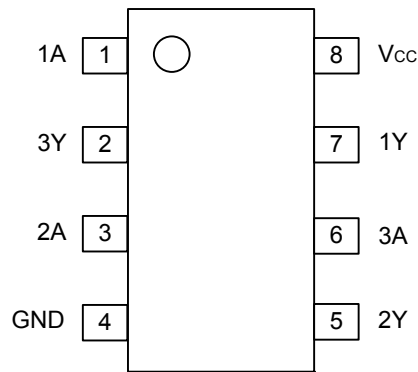

■ FUNCTION TABLE (each gate)

INPUT	OUTPUT
A	Y
L	L
H	H

■ LOGIC DIAGRAM (positive logic)

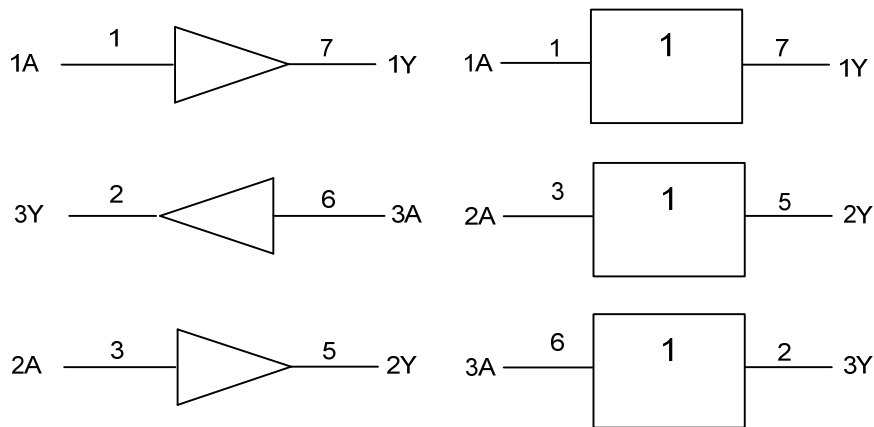

■ ABSOLUTE MAXIMUM RATINGS (unless otherwise specified)

PARAMETER	SYMBOL	RATINGS	UNIT
Supply Voltage	V_{CC}	-0.5~7	V
Output Voltage	V_{OUT}	-0.5~ $V_{CC}+0.5$	V
Output Current	I_{OUT}	25	mA
V_{CC} or GND Current	I_{CC}	50	mA
Input Clamp Current	I_{IK}	± 20	mA
Output Clamp Current	I_{OK}	± 20	mA
Power Dissipation	P_D	300	mW
Storage Temperature	T_{STG}	-65 ~ +150	$^{\circ}C$

Note: Absolute maximum ratings are those values beyond which the device could be permanently damaged.

Absolute maximum ratings are stress ratings only and functional device operation is not implied.

■ RECOMMENDED OPERATING CONDITIONS

PARAMETER	SYMBOL	CONDITIONS	MIN	TYP	MAX	UNIT
Supply Voltage	V_{CC}		4.5	5.0	5.5	V
Input Voltage	V_{IN}		0		V_{CC}	V
Output Voltage	V_{OUT}		0		V_{CC}	V
Input Rise and Fall Times	t_R, t_F	$V_{CC}=4.5V$		6.0	500	ns
Operating Temperature	T_A		-40		+125	$^{\circ}C$

■ STATIC CHARACTERISTICS ($T_A=25^{\circ}C$)

PARAMETER	SYMBOL	TEST CONDITIONS	MIN	TYP	MAX	UNIT
High-Level Input Voltage	V_{IH}	$V_{CC}=4.5V\sim 5.5V$	2.0	1.6		V
Low-Level Input Voltage	V_{IL}	$V_{CC}=4.5V\sim 5.5V$		1.2	0.8	V
High-Level Output Voltage	V_{OH}	$V_{CC}=4.5V, I_{OH}=-20\mu A$	4.4	4.5		V
		$V_{CC}=4.5V, I_{OH}=-4.0mA$	4.13	4.32		V
Low-Level Output Voltage	V_{OL}	$V_{CC}=4.5V, I_{OL}=20\mu A$		0	0.1	V
		$V_{CC}=4.5V, I_{OL}=4.0mA$		0.15	0.33	V
Input Leakage Current	$I_{I(LEAK)}$	$V_{CC}=5.5V, V_{IN}=V_{CC}$ or GND			± 1.0	μA
Quiescent Supply Current	I_Q	$V_{CC}=5.5V, I_{OUT}=0, V_{IN}=V_{CC}$ or GND			10	μA
Additional Quiescent Supply Current	ΔI_Q	$V_{CC}=5.5V, V_{IN}=V_{CC}-2.1V; I_{OUT}=0$			375	μA
Input Capacitance	C_{IN}			1.5		pF

■ DYNAMIC CHARACTERISTICS ($T_A=25^{\circ}C, t_R, t_F \leq 6.0ns$)

PARAMETER	SYMBOL	TEST CONDITIONS	MIN	TYP	MAX	UNIT
Propagation Delay From nA to nY	t_{PHL}/t_{PLH}	$V_{CC}=4.5V, C_L=50 pF$		10	23	ns
Output Transition Time	t_{THL}/t_{TLH}	$V_{CC}=4.5V, C_L=50 pF$		6	19	ns

■ OPERATING CHARACTERISTICS

PARAMETER	SYMBOL	TEST CONDITION	MIN	TYP	MAX	UNIT
Power Dissipation Capacitance per Gate	C_{pd}			9		pF

■ T TEST CIRCUIT AND WAVEFORMS

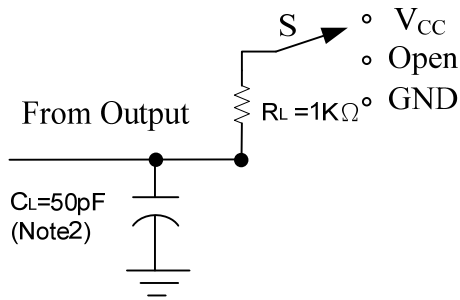

TEST	S
t_{PLH}/t_{PHL}	Open
t_{PHZ}/t_{PZH}	GND
t_{PLZ}/t_{PZL}	V_{CC}

Note: C_L includes probe and jig capacitance.

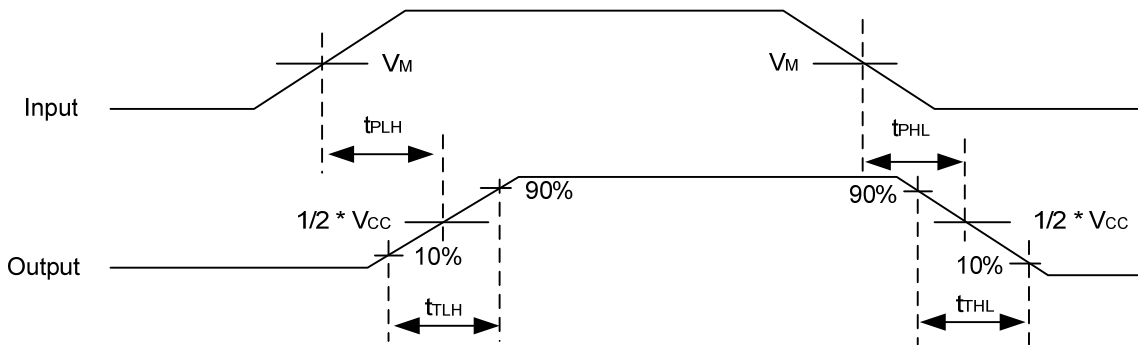

$V_M=1.3V, Input=GND\ to\ 3.0V$

UTC assumes no responsibility for equipment failures that result from using products at values that exceed, even momentarily, rated values (such as maximum ratings, operating condition ranges, or other parameters) listed in products specifications of any and all UTC products described or contained herein. UTC products are not designed for use in life support appliances, devices or systems where malfunction of these products can be reasonably expected to result in personal injury. Reproduction in whole or in part is prohibited without the prior written consent of the copyright owner. The information presented in this document does not form part of any quotation or contract, is believed to be accurate and reliable and may be changed without notice.