



U74HC540

CMOS IC

OCTAL BUFFERS AND LINE DRIVERS WITH 3-STATE OUTPUTS

DESCRIPTION

The **U74HC540** combines with octal buffers and line drivers with inverting 3-tate outputs. The 3-state output is controlled by output enable inputs $\overline{OE1}$ and $\overline{OE2}$, all eight outputs will be in high-impedance when either of the 2 inputs is applied with high voltage.

FEATURES

- * Operation voltage range: 2V ~ 6V
- * High-current 3-state outputs for bus driver
- * Inverting outputs

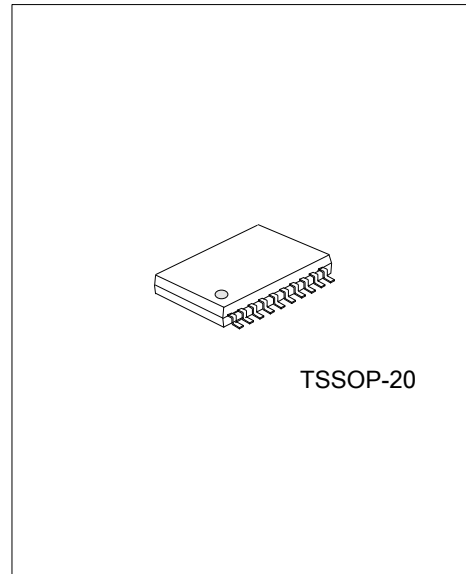

ORDERING INFORMATION

Ordering Number	Package	Packing
U74HC540G-P20-R	TSSOP-20	Tape Reel

<p>U74HC540G-P20-R</p> <ul style="list-style-type: none"> (1) Packing Type (2) Package Type (3) Green Package 	<ul style="list-style-type: none"> (1) R: Tape Reel (2) P20: TSSOP-20 (3) G: Halogen Free and Lead Free
--	--

MARKING

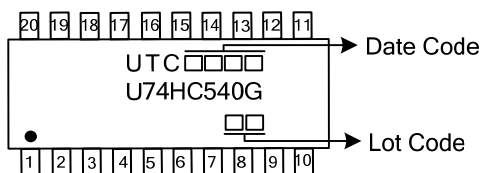

■ PIN CONFIGURATION

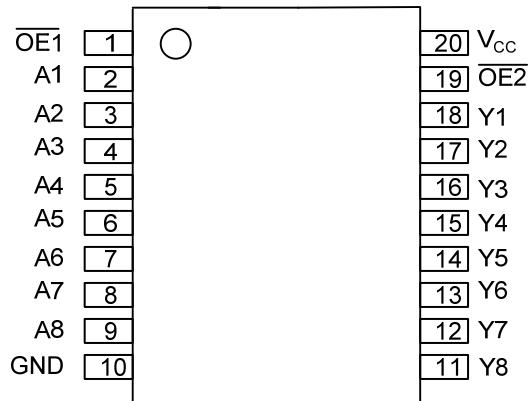

■ FUNCTION TABLE (each gate)

INPUT		OUTPUT	
$\overline{OE1}$	$\overline{OE2}$	A	Y
L	L	L	H
L	L	H	L
H	X	X	Z
X	H	X	Z

■ LOGIC DIAGRAM (positive logic)

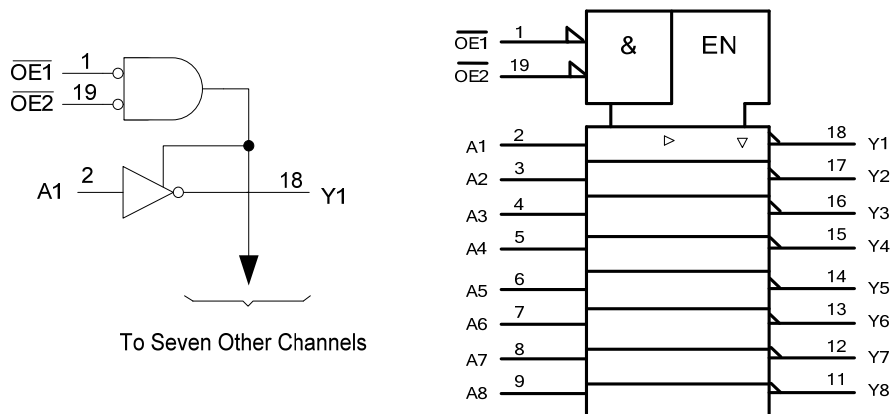

■ ABSOLUTE MAXIMUM RATINGS (unless otherwise specified)(Note 1)

PARAMETER	SYMBOL	RATINGS	UNIT
Supply Voltage	V_{CC}	-0.5~7	V
Input Clamp Current	I_{IK}	±20	mA
Output Clamp Current	I_{OK}	±20	mA
Output Current	I_{OUT}	±35	mA
V_{CC} or GND Current	I_{CC}	±70	mA
Storage Temperature	T_{STG}	-65 ~ +150	°C

Note 1. The input and output voltage ratings may be exceeded if the input and output current ratings are observed.

2. Absolute maximum ratings are those values beyond which the device could be permanently damaged.

Absolute maximum ratings are stress ratings only and functional device operation is not implied.

■ RECOMMENDED OPERATING CONDITIONS

PARAMETER	SYMBOL	CONDITIONS	MIN	TYP	MAX	UNIT
Supply Voltage	V_{CC}		2	5	6	V
Input Voltage	V_{IN}		0		V_{CC}	V
Output Voltage	V_{OUT}		0		V_{CC}	V
Input Transition Rise or Fall Rate	t_R, t_F	$V_{CC}=2V$	0		1000	ns
		$V_{CC}=4.5V$	0		500	
		$V_{CC}=6V$	0		400	
Operating Temperature	T_A		-40		85	°C

■ ELECTRICAL CHARACTERISTICS

PARAMETER	SYMBOL	TEST CONDITIONS	$T_A = 25^\circ C$			$-40 \sim 85^\circ C$		UNIT
			MIN	TYP	MAX	MIN	MAX	
High-Level Input Voltage	V_{IH}	$V_{CC}=2V$				1.5		V
		$V_{CC}=4.5V$				3.15		
		$V_{CC}=6V$				4.2		
Low-Level Input Voltage	V_{IL}	$V_{CC}=2V$					0.5	V
		$V_{CC}=4.5V$					1.35	
		$V_{CC}=6V$					1.8	
High-Level Output Voltage	V_{OH}	$V_{CC}=2V, I_{OH}=-20\mu A$	1.9	1.998		1.9		V
		$V_{CC}=4.5V, I_{OH}=-20\mu A$	4.4	4.499		4.4		
		$V_{CC}=6V, I_{OH}=-20\mu A$	5.9	5.999		5.9		
		$V_{CC}=4.5V, I_{OH}=-6mA$	3.98	4.3		3.84		
		$V_{CC}=6V, I_{OH}=-7.8mA$	5.48	5.8		5.34		
Low-Level Output Voltage	V_{OL}	$V_{CC}=2V, I_{OH}=20\mu A$		0.002	0.1		0.1	V
		$V_{CC}=4.5V, I_{OH}=20\mu A$		0.001	0.1		0.1	
		$V_{CC}=6V, I_{OH}=20\mu A$		0.001	0.1		0.1	
		$V_{CC}=4.5V, I_{OL}=6mA$		0.17	0.26		0.33	
		$V_{CC}=6V, I_{OL}=7.8mA$		0.15	0.26		0.33	
Input Leakage Current	$I_{I(LEAK)}$	$V_{CC}=6V, V_{IN}=V_{CC}$ or GND		±0.1	±100		±1000	nA
Output Leakage Current	$I_{O(LEAK)}$	$V_{CC}=6V, V_{OUT}=V_{CC}$ or GND		±0.01	±0.5		±5	uA
Quiescent Supply Current	I_Q	$V_{CC}=6V, V_{IN}=V_{CC}$ or GND, $I_{OUT}=0$			8		80	μA
Input Capacitance	C_{IN}	$V_{CC}=2V \sim 6V$		3	10		10	pF

■ SWITCHING CHARACTERISTICS ($t_R, t_F \leq 3\text{ns}$)

PARAMETER	SYMBOL	TEST CONDITIONS	$T_A=25^\circ\text{C}$			$-40\sim 85^\circ\text{C}$		UNIT
			MIN	TYP	MAX	MIN	MAX	
Propagation delay from input (A) to output(Y)	t_{PLH}/ t_{PHL}	$V_{CC}=2\text{V}, C_L=50\text{ pF}$		35	100		125	ns
		$V_{CC}=2\text{V}, C_L=150\text{ pF}$		60	150		188	
		$V_{CC}=4.5\text{V}, C_L=50\text{ pF}$		10	20		25	
		$V_{CC}=4.5\text{V}, C_L=150\text{ pF}$		15	30		38	
		$V_{CC}=6\text{V}, C_L=50\text{ pF}$		8	17		21	
		$V_{CC}=6\text{V}, C_L=150\text{ pF}$		13	26		32	
3-state output enable time from \overline{OE} to Y_n	t_{PZH}/ t_{PZL}	$V_{CC}=2\text{V}, C_L=50\text{ pF}$		75	150		188	ns
		$V_{CC}=2\text{V}, C_L=150\text{ pF}$		100	200		250	
		$V_{CC}=4.5\text{V}, C_L=50\text{ pF}$		15	30		38	
		$V_{CC}=4.5\text{V}, C_L=150\text{ pF}$		20	40		50	
		$V_{CC}=6\text{V}, C_L=50\text{ pF}$		13	26		32	
		$V_{CC}=6\text{V}, C_L=150\text{ pF}$		17	34		43	
3-state output disable time from \overline{OE} to Y_n	t_{PHZ}/ t_{PLZ}	$V_{CC}=2\text{V}, C_L=50\text{ pF}$		40	150		188	ns
		$V_{CC}=4.5\text{V}, C_L=50\text{ pF}$		18	30		38	
		$V_{CC}=6\text{V}, C_L=50\text{ pF}$		17	26		32	

■ OPERATING CHARACTERISTICS

PARAMETER	SYMBOL	TEST CONDITIONS	MIN	TYP	MAX	UNIT
Power Dissipation Capacitance	Cpd	No load, $f=1\text{MHz}$		35		pF

■ TEST CIRCUIT AND WAVEFORMS

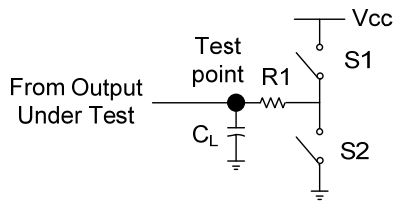

Note: C_L includes probe and jig capacitance.

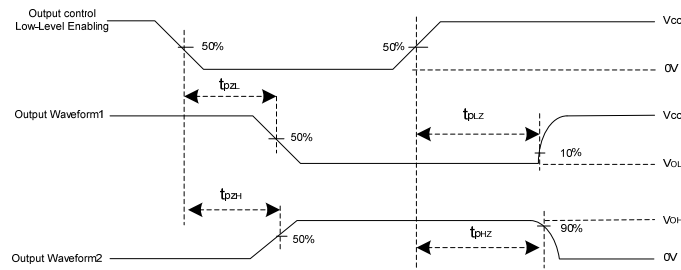
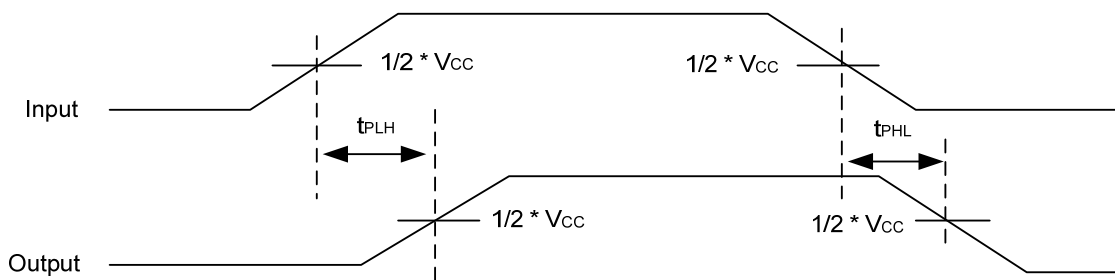

UTC assumes no responsibility for equipment failures that result from using products at values that exceed, even momentarily, rated values (such as maximum ratings, operating condition ranges, or other parameters) listed in products specifications of any and all UTC products described or contained herein. UTC products are not designed for use in life support appliances, devices or systems where malfunction of these products can be reasonably expected to result in personal injury. Reproduction in whole or in part is prohibited without the prior written consent of the copyright owner. The information presented in this document does not form part of any quotation or contract, is believed to be accurate and reliable and may be changed without notice.