



UAC3092A

LINEAR INTEGRATED CIRCUIT

ALTERNATOR VOLTAGE REGULATOR

DESCRIPTION

The UTC **UAC3092A** is designed for Load Response Control and voltage regulation of diode rectified alternator charging systems for automotive applications.

FEATURES

- * Forced load response control (LRC) with heavy load transitions at low RPM
- * Voltage regulated to $\pm 0.1V @ 25^{\circ}C$
- * External resistor adjustable operating frequency
- * Regulation is effective with loads as high as 1.0A
- * Load dump protection of lamp, field control devices, and loads
- * Undervoltage, overvoltage, phase fault (broken belt) detection and duty cycle limited protections

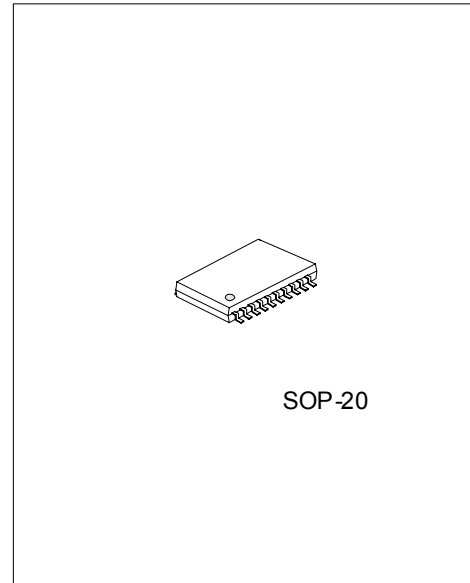

*Pb-free plating product number: UAC3092AL

ORDERING INFORMATION

Order Number		Package	Packing
Normal	Lead Free Plating		
UAC3092A-S20-R	UAC3092AL-S20-R	SOP-20	Tape Reel
UAC3092A-S20-T	UAC3092AL-S20-T	SOP-20	Tube

<p>UAC3092AL-S20-R</p> <p>(1)Packing Type</p> <p>(2)Package Type</p> <p>(3)Lead Plating</p>	<p>(1) R: Tape Reel, T: Tube</p> <p>(2) S20: SOP-20</p> <p>(3) L: Lead Free Plating, Blank: Pb/Sn</p>
---	---

■ PIN CONFIGURATION

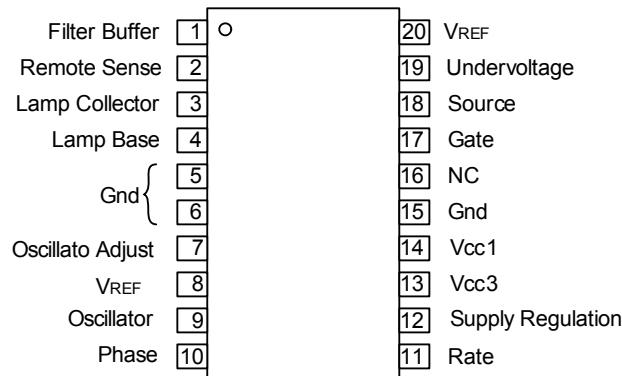

■ PIN DESCRIPTION

PIN NO.	PIN NAME	DESCRIPTION
1	FB	This pin provides Sense input or the Supply Regulation input.
2	Sense	The Sense input is input for the true battery voltage.
3	Lamp Collector and Power-Up/Down	This pin connects to drive the fault lamp. It is also used to sense a closed ignition switch (voltage sense).
4	Lamp Base	This pin provides base current to the fault lamp drive transistor (Q2).
5	Ground	This pin is for Ground return for the fault lamp control logic circuit.
6	Ground	IC ground
7	Oscillator Adjust	Connected to a resistor to ground that adjusts the internal oscillator frequency
8	V _{REF} Φ	This is a pin for the 1.1 V ~ 1.4 V reference voltage test.
9	Oscillator	This is a pin for checking the operation of the internal oscillator.
10	Phase	The Phase input detects the existence of a magnetic field rotating within the alternator.
11	Rate	The Rate pin is Load Response Control recovery rate selector pin used to select a slow mode (floating) or fast mode (ground).
12	Supply Regulation	The Supply Regulation pin is used as a representation of the alternator output voltage. This input also used to monitor overvoltage or load dump conditions.
13	Vcc3	Voltage supply for the internal Charge Pump.
14	Vcc1	Voltage supply for the entire IC except for the Charge Pump.
15	Ground	Ground for the IC.
16	N/C	No connection.
17	Gate	The Gate Controls of the MOSFET used to energize the field winding.
18	Source	MOSFET source reference for Field winding control.
19	Undervoltage	If this pin have voltage goes below 1.0 V, the fault lamp is turn on. The IC will continue to function, but with limited performance.
20	V _{REF}	Pin for the Band gap reference voltage 1.7 V ~ 2.3 V.

Note: Pin 8, and 20 are test points only

■ BLOCK DIAGRAM

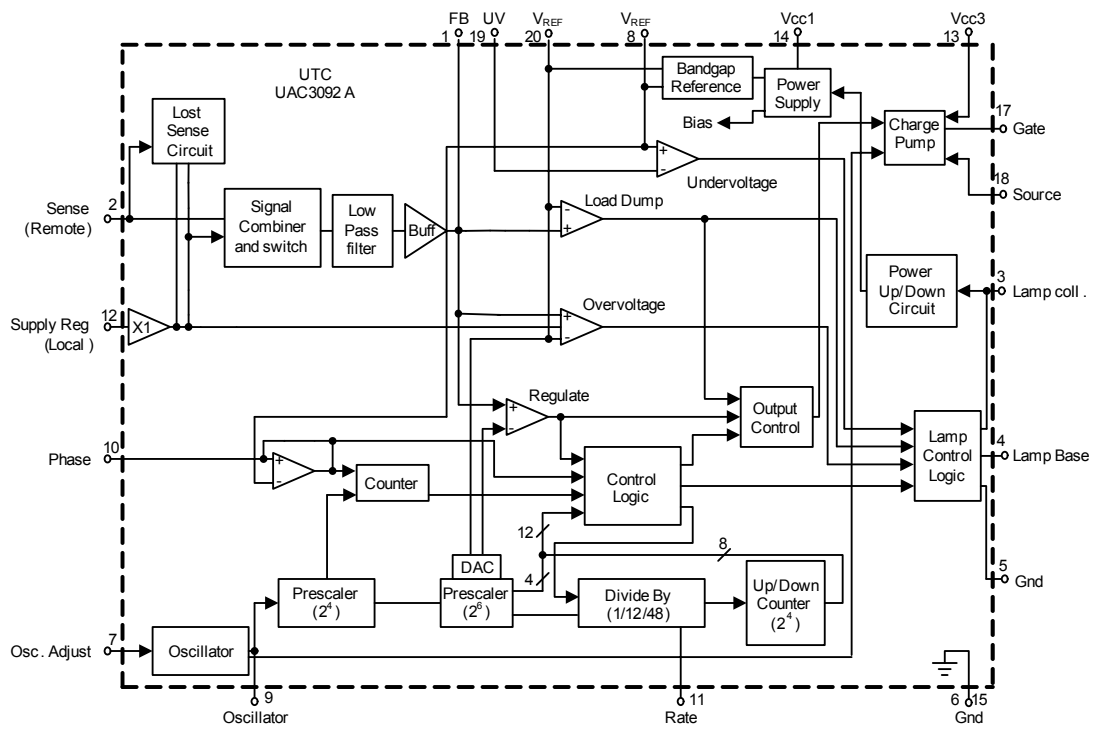

■ ABSOLUTE MAXIMUM RATINGS

(Ta=25)

PARAMETER	SYMBOL	RATINGS	UNIT
Power Supply Voltage	V _{BAT}	24	V
Load Dump Transient Voltage (Note 1)	+V _{MAX}	40	
Negative Voltage (Note 2)	-V _{MIN}	-2.5	
Power Dissipation (Ta=125)	P _D	867	m/W
Operating Junction Temperature	T _J	+150	
Operating Ambient Temperature Range	T _{OPR}	-35 ~ +125	
Storage Temperature Range	T _{STG}	-45 ~ +150	

Note: 1. 125 ms wide square wave pulse.

2. Maximum time = 2 minutes.

3. Absolute maximum ratings are those values beyond which the device could be permanently damaged.

Absolute maximum ratings are stress ratings only and functional device operation is not implied.

■ THERMAL DATA

PARAMETER	SYMBOL	RATINGS	UNIT
Thermal Resistance, Junction to Ambient	θ _{JA}	75	°C/W

■ ELECTRICAL CHARACTERISTICS

(External components per Figure 1, Ta=25 , unless otherwise noted.)

PARAMETER	SYMBOL	TEST CONDITIONS	MIN	TYP	MAX	UNIT
DC CHARACTERISTICS						
Regulation Voltage	V _{REG}	Determined by external resistor divider		14.85		V
Regulation Voltage Temperature Coefficient	T _C		-13	-11	-9.0	mV/
Suggested Battery Voltage Operating Range	V _{BAT}		11.5	14.85	16.5	V
Power Up/Down Threshold Voltage (Pin 3)	V _{PWR}		0.5	1.2	2.0	V
Standby Current	I _{Q1} I _{Q2}	V _{BAT} =12.8V, Ignition off, Ta=25 V _{BAT} =12.8V, Ignition off, -35 ≤Ta≤125		1.3	2.0 3.0	mA
Zero Temperature Coefficient Reference Voltage, (Pin 8)	V _{REFΦ}		1.1	1.25	1.4	V
Band Gap Reference Voltage (Pin 20)	V _{REF}		1.7	2.0	2.3	V
Band Gap Reference Temperature coefficient	TC		-13	-11	-9.0	mV/
Sense Loss Threshold (Pin 2)	S _{LOSS (TH)}			0.6	1.0	V
Phase Detection Threshold Voltage (Pin 10)	P _{TH}		1.0	1.25	1.5	V
Phase Rotation Detection Frequency (Pin 10)	P _{ROT}			36		Hz
Undervoltage Threshold (Pin 19)	U _{UV}		1.0	1.25	1.5	V
Overvoltage Threshold	V _{OV}	Pin 2, or Pin 12 if Pin 2 is not used	1.09(V _{REF})	1.12(V _{REF})	1.16(V _{REF})	V
Load Dump Threshold	V _{LD}	Pin 2, or Pin 12 if Pin 2 is not used	1.33(V _{REF})	1.4(V _{REF})	1.48(V _{REF})	V

■ ELECTRICAL CHARACTERISTIC(Cont.)

PARAMETER	SYMBOL	TEST CONDITIONS	MIN	TYP	MAX	UNIT
SWITCHING CHARACTERISTICS						
Fundamental Regulation Output Frequency. (Pin 17)	f	Clock oscillator frequency divided by 4096		68		Hz
Suggested Clock Oscillator Frequency Range, (Pin 9)	f _{osc}	Determined by external resistor, R _T	205	280	350	kHz
Duty Cycle (Pin 17) At Start-up During Overvoltage Condition	StartDC		27	29	31	%
	OV _{DC}		3.5	4.7	5.5	%
Low/High RPM Transition Frequency (Pin 10)	LRC _{Freq}		247	273	309	Hz
LRC Duty Cycle Increase Rate	LRC _S	Low RPM Mode(LRCFreq<247Hz) Pin 11 =Open (Slow Rate)	8.5	9.5	10.5	% /sec
	LRC _F	Low RPM Mode(LRCFreq<247Hz) Pin 11 =Grounded (Fast Rate)	34	38	42	
	LRC _H	High R PMMode(LRCFreq>309Hz) Pin 11 = Don't Care (LRC Mode is disabled)	409	455	501	

UTC assumes no responsibility for equipment failures that result from using products at values that exceed, even momentarily, rated values (such as maximum ratings, operating condition ranges, or other parameters) listed in products specifications of any and all UTC products described or contained herein. UTC products are not designed for use in life support appliances, devices or systems where malfunction of these products can be reasonably expected to result in personal injury. Reproduction in whole or in part is prohibited without the prior written consent of the copyright owner. The information presented in this document does not form part of any quotation or contract, is believed to be accurate and reliable and may be changed without notice.