



UHS49

Preliminary

LINEAR INTEGRATED CIRCUIT

LINEAR HALL EFFECT SENSOR

DESCRIPTION

UTC **UHS49** Linear Hall-effect sensor is small, versatile linear Hall-effect device that is operated by the magnetic field from a permanent magnet or an electromagnet. The linear sourcing output voltage is set by the supply voltage and varies in proportion to the strength of the magnetic field. The IC features low noise output, which makes it unnecessary to use external filtering. It also includes thin film resistors to provide increased temperature stability and accuracy. The linear Hall sensor can be used for Motor control, Magnetic code reading, Ferrous metal detector, Current sensing and Position sensing .

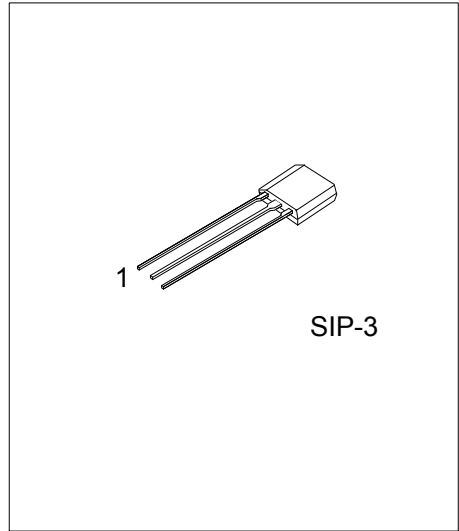

FEATURES

- * Low-Noise Output
- * 4.5 V ~ 6 V Operation
- * Magnetically Optimized Package
- * Miniature construction
- * Linear output for circuit design flexibility
- * Wide ambient temperature range: -40°C ~ +85°C

ORDERING INFORMATION

Ordering Number	Package	Pin Assignment			Packing
		1	2	3	
UHS49G-G03-B	SIP-3	I	G	O	Tape Box
UHS49G-G03-K	SIP-3	I	G	O	Bulk

Note: Pin Assignment: I: V_{DD} G: GND O: V_{OUT}

<p>UHS49G-G03-R</p>	<p>(1) B: Tape Box, K: Bulk</p> <p>(2) G03: SIP-3</p> <p>(3) G: Halogen Free and Lead Free</p>
---------------------	--

MARKING

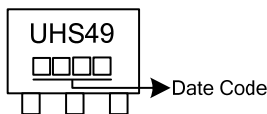

■ PIN DESCRIPTION

PIN NO.	PIN NAME	DESCRIPTION
1	V _{DD}	Supply Voltage
2	GND	IC Ground
3	V _{OUT}	Output

■ BLOCK DIAGRAM

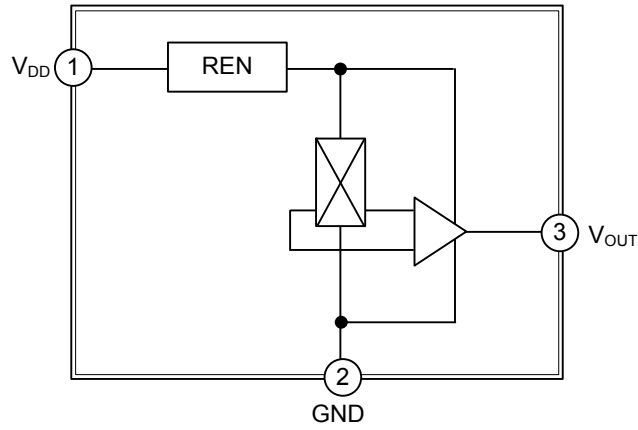

■ ABSOLUTE MAXIMUM RATINGS ($T_A=25^\circ\text{C}$, unless otherwise specified)

PARAMETER	SYMBOL	RATINGS	UNIT
Supply Voltage	V_{CC}	8.0	V
Circuit Current	I_O	20	mA
Power Dissipation	P_D	400	mW
Operating Temperature	T_{OPR}	-30 ~ +125	$^\circ\text{C}$
Storage Temperature	T_{STG}	-40 ~ +150	$^\circ\text{C}$

Note: Absolute maximum ratings are those values beyond which the device could be permanently damaged. Absolute maximum ratings are stress ratings only and functional device operation is not implied.

■ ELECTRICAL CHARACTERISTICS ($T_A=25^\circ\text{C}$, $V_{DD}=5\text{V}$)

PARAMETER	SYMBOL	TEST CONDITIONS	MIN	TYP	MAX	UNIT
Operating Voltage	V_{CC}	operating	3.0		6.5	V
Supply Current	I_{CC}	Average		4.2	8.0	mA
Output Current	I_{OUT}		1.0	1.5		mA
Response Time	T_{ack}			3		μS
Quiescent Output Voltage	V_O	B=0G		2.35		V
Sensitivity	ΔV_{OUT}	$T_A=25^\circ\text{C}$		1.2		mV/G
Min Output Voltage		B=-500G		1.6		V
Max Output Voltage		B=500G		3.15		V

■ TYPICAL APPLICATION CIRCUIT

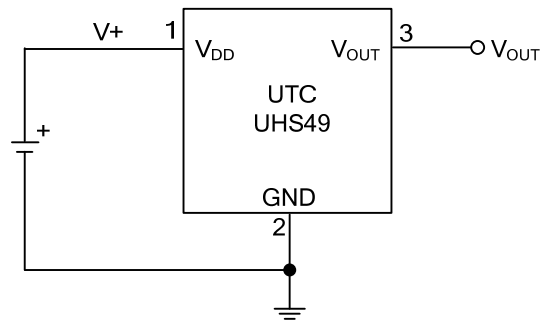

UTC assumes no responsibility for equipment failures that result from using products at values that exceed, even momentarily, rated values (such as maximum ratings, operating condition ranges, or other parameters) listed in products specifications of any and all UTC products described or contained herein. UTC products are not designed for use in life support appliances, devices or systems where malfunction of these products can be reasonably expected to result in personal injury. Reproduction in whole or in part is prohibited without the prior written consent of the copyright owner. The information presented in this document does not form part of any quotation or contract, is believed to be accurate and reliable and may be changed without notice.