



## UHS41

Preliminary

LINEAR INTEGRATED CIRCUIT

### HALL-EFFECT LATCHED SENSOR

#### DESCRIPTION

The UTC **UHS41** is an integrated Hall effect latched sensor designed for electronic commutation of brush-less DC motor applications. The device includes a voltage regulator, reverse battery protection diode, Hall sensor with dynamic offset cancellation system, temperature compensation circuitry, small signal amplifier, Schmitt trigger and an open-collector output to sink up to 25mA.

These Hall-effect switches are monolithic integrated circuits with tighter magnetic specifications, and are more stable with both temperature and supply voltage changes. If a magnetic flux density larger than threshold Bop, Output is turned on (low). The output state is held until a magnetic flux density reversal falls below Brp, causing Output to be turned off (high).

Thanks to its wide operating voltage range and extended choice of temperature range, it is quite suitable for use in DC motor applications. It also can be used for Automotive, Consumer and Industrial, Solid-state switch, Speed measurement, Revolution counting, Angular position detection and Proximity detection.

#### FEATURES

- \* wide operating voltage range: 4.5V~24V
- \* Wide ambient temperature range: -40°~150°C
- \* Bipolar technology
- \* Open-collector 25mA output
- \* Reverse battery protection
- \* Solid-state reliability
- \* Resistant to physical stress
- \* Activate with small, commercially available permanent magnets

#### ORDERING INFORMATION

Ordering Number	Package	Pin Assignment			Packing
		1	2	3	
UHS41G-G03-B	SIP-3	I	G	O	Tape Box
UHS41G-G03-K	SIP-3	I	G	O	Bulk

Note: Pin Assignment: I: V<sub>DD</sub> G: GND O: V<sub>OUT</sub>

<p>UHS41G-G03-R</p> <p>(1)Packing Type</p> <p>(2)Package Type</p> <p>(3)Green Package</p>	<p>(1) B: Tape Box, K: Bulk</p> <p>(2) G03: SIP-3</p> <p>(3) G: Halogen Free and Lead Free</p>
---	--

#### MARKING

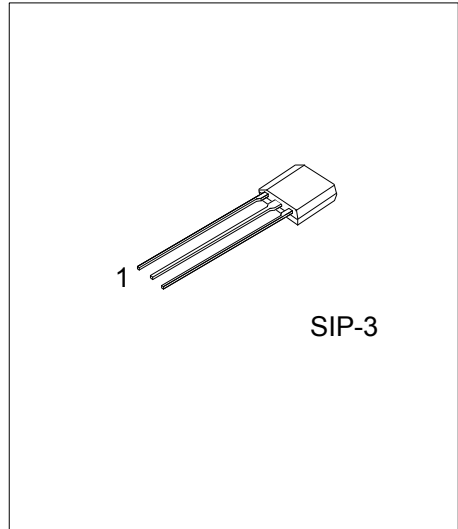

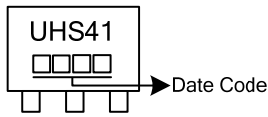

■ PIN DESCRIPTION

PIN NO.	PIN NAME	DESCRIPTION
1	V <sub>DD</sub>	Supply Voltage pin
2	OUT	Open Drain Output pin
3	GND	Ground pin

■ BLOCK DIAGRAM

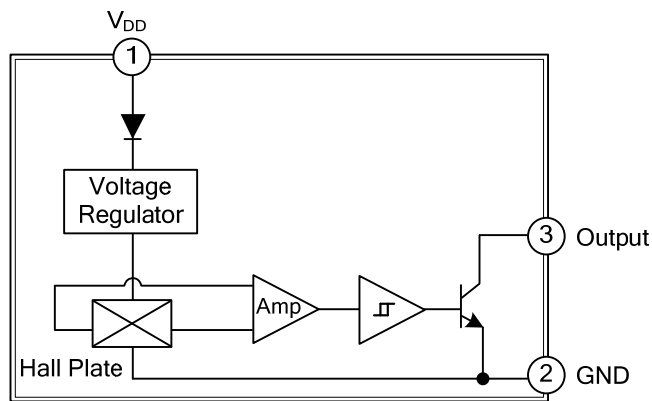

### ■ ABSOLUTE MAXIMUM RATING

PARAMETER	SYMBOL	RATINGS	UNIT
Supply Voltage	$V_{DD}$	28	V
Supply Current	$I_{DD}$	50	mA
Output Voltage	$V_{OUT}$	28	V
Output Current	$I_{OUT}$	50	mA
Storage Temperature Range	$T_S$	-65~170	°C
<b>Operating Temperature Range</b>			
Operating Temperature	$T_A$	-40~+85	°C

Note: Absolute maximum ratings are those values beyond which the device could be permanently damaged. Absolute maximum ratings are stress ratings only and functional device operation is not implied.

### ■ ELECTRICAL CHARACTERISTICS

(DC Operating Parameters  $T_A=25^{\circ}\text{C}$ ,  $V_{DD}=4.5\text{V}\sim 24\text{V}$ , unless otherwise specified)

PARAMETER	SYMBOL	TEST CONDITIONS	MIN	TYP	MAX	UNIT
Supply Voltage	$V_{DD}$	Operating	4.5		24	V
Supply Current	$I_{DD}$	$B < B_{RP}$		5	10	mA
Output Saturation Voltage	$V_{DSon}$	$I_{OUT}=20\text{mA}$ , $B > B_{OP}$		0.4	0.5	V
Output Leakage Current	$I_{OFF}$	$B < B_{RP}$ , $V_{OUT}=24\text{V}$		0.01	5	uA
Output Rise Time	$t_R$	$R_L=1\text{K}\Omega$ , $C_L=20\text{pF}$		0.3	1.5	us
Output Fall Time	$t_F$	$R_L=1\text{K}\Omega$ , $C_L=20\text{pF}$		0.3	1.5	us

### ■ MAGNETIC SPECIFICATIONS

DC Operating Parameters  $V_{DD}=4.5\text{V}\sim 24\text{V}$  (unless otherwise specified)

PARAMETER	SYMBOL	TEST CONDITIONS	MIN	TYP	MAX	UNIT
Operating Point	$B_{OP}$	$T_A=25^{\circ}\text{C}$ , $V_{DD}=5\text{V DC}$	5	37	70	G
Release Point	$B_{RP}$		-70	-37	-5	G
Hysteresis	$B_{HYS}$			75		G

■ TYPICAL APPLICATION CIRCUIT

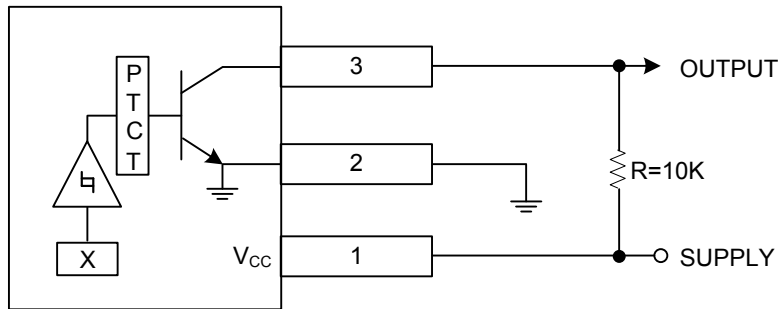

UTC assumes no responsibility for equipment failures that result from using products at values that exceed, even momentarily, rated values (such as maximum ratings, operating condition ranges, or other parameters) listed in products specifications of any and all UTC products described or contained herein. UTC products are not designed for use in life support appliances, devices or systems where malfunction of these products can be reasonably expected to result in personal injury. Reproduction in whole or in part is prohibited without the prior written consent of the copyright owner. The information presented in this document does not form part of any quotation or contract, is believed to be accurate and reliable and may be changed without notice.