



U74LVC1G3157

CMOS IC

SINGLE-POLE, DOUBLE-THROW ANALOG SWITCH

DESCRIPTION

The UTC **U74LVC1G3157** is a low voltage single-pole, double-throw (SPDT) analog switch intending for use in chopping, modem, signal gating, and signal multiplexing for analog-to-digital and digital-to-analog conversion systems.

FEATURES

- * Useful in Both Analog and Digital Applications
- * Rail-to-Rail Signal Handling
- * Low ON Resistance: < 10Ω on Typical @ 3.3V V_{CC}
- * Broad V_{CC} Operating Range: 1.65V to 5.5V
- * Over-Voltage Tolerance of Control Input to 7.0V

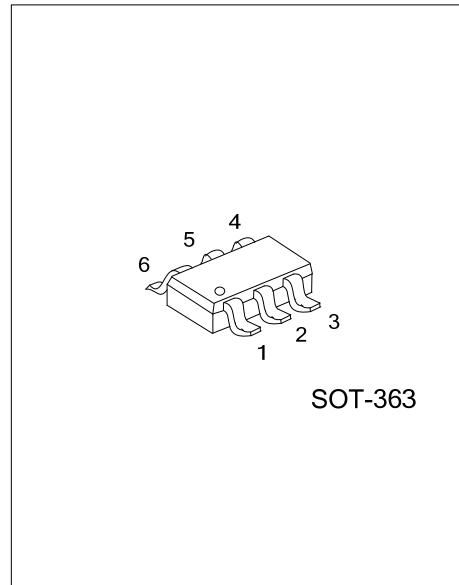

ORDERING INFORMATION

Ordering Number		Package	Packing
Lead Free	Halogen Free		
U74LVC1G3157L-AL6-R	U74LVC1G3157G-AL6-R	SOT-363	Tape Reel

<p>U74LVC1G3157L-AL6-R</p> <p>(1) Packing Type (2) Package Type (3) Lead Free</p>	<p>(1) R: Tape Reel (2) AL6: SOT-363 (3) G: Halogen Free, L: Lead Free</p>
-------------------------------------------------------------------------------------------	------------------------------------------------------------------------------------

MARKING

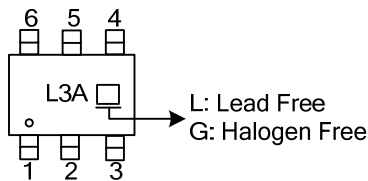

■ PIN CONFIGURATION

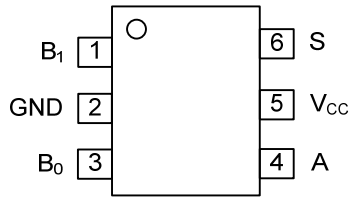

■ FUNCTION TABLE

INPUT(S)	OUTPUT(Y)
L	B0 Connected to A
H	B1 Connected to A

H=High Level
L=Low Level

■ LOGIC DIAGRAM

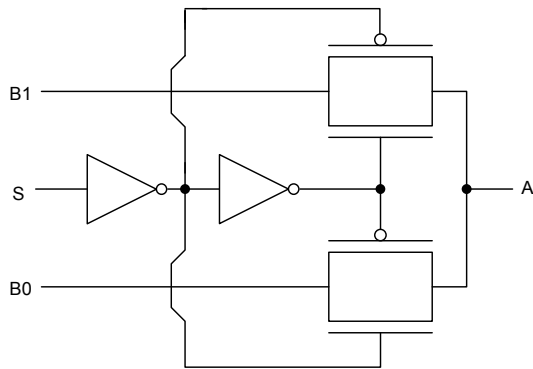

Logic Symbol

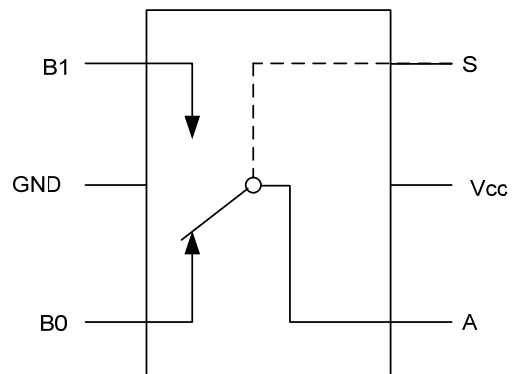

Analog Symbol

■ ABSOLUTE MAXIMUM RATING

PARAMETER	SYMBOL	RATINGS	UNIT
Supply Voltage	V_{CC}	-0.5 ~ +7.0	V
Switch Voltage	V_S	-0.5 ~ $V_{CC}+0.5$	V
Input Voltage	V_{IN}	-0.5 ~ +7.0	V
V_{CC} or GND Current	I_{CC}	±100	mA
Continuous Output Current	I_{OUT}	128	mA
Input Clamp Current ($V_{IN}<0V$)	I_{IK}	-50	mA
Operating Temperature	T_{OPR}	-40 ~ + 85	°C
Storage Temperature	T_{STG}	-65 ~ + 150	°C

Note: Absolute maximum ratings are those values beyond which the device could be permanently damaged.

Absolute maximum ratings are stress ratings only and functional device operation is not implied.

■ THERMAL DATA

PARAMETER	SYMBOL	RATINGS	UNIT
Junction to Ambient	θ_{JA}	270	°C/W

■ RECOMMENDED OPERATING CONDITIONS

PARAMETER	SYMBOL	TEST CONDITIONS	MIN	TYP	MAX	UNIT
Supply Voltage	V_{CC}		1.65		5.5	V
Control Input Voltage	V_{IN}	(Note)	0		V_{CC}	V
Switch Input Voltage	V_{IN}	(Note)	0		V_{CC}	V
Output Voltage	V_{OUT}	(Note)	0		V_{CC}	V
High-level Input Voltage	V_{IH}	$V_{CC}=1.65V$ to $1.95V$	$0.75 \times V_{CC}$			V
		$V_{CC}=2.3V$ to $5.5V$	$0.7 \times V_{CC}$			V
Low-level Input Voltage	V_{IL}	$V_{CC}=1.65V$ to $1.95V$			$0.25 \times V_{CC}$	V
		$V_{CC}=2.3V$ to $5.5V$			$0.3 \times V_{CC}$	V
Input Rise or Fall Times	$\frac{\Delta t}{\Delta V}$	Control Input $V_{CC}=2.3V \sim 3.6V$			10	ns/V
		Control Input $V_{CC}=4.5V \sim 5.5V$			5	ns/V

Note: Control input must be held HIGH or LOW; it must not float

■ ELECTRICAL CHARACTERISTICS ($T_A=25^\circ C$, unless otherwise specified)

PARAMETER	SYMBOL	TEST CONDITIONS	MIN	TYP	MAX	UNIT
Switch On Resistance	R_{ON}	$V_{CC}=4.5V, V_{IN}=0V, I_{OUT}=30mA$		3.0	7.0	Ω
		$V_{CC}=4.5V, V_{IN}=2.4V, I_{OUT}=-30mA$		5.0	12.0	Ω
		$V_{CC}=4.5V, V_{IN}=4.5V, I_{OUT}=-30mA$		7.0	15.0	Ω
		$V_{CC}=3V, V_{IN}=0V, I_{OUT}=24mA$		4.0	9.0	Ω
		$V_{CC}=3V, V_{IN}=3V, I_{OUT}=-24mA$		10.0	20.0	Ω
		$V_{CC}=2.3V, V_{IN}=0V, I_{OUT}=8mA$		5.0	12.0	Ω
		$V_{CC}=2.3V, V_{IN}=2.3V, I_{OUT}=-8mA$		13.0	30.0	Ω
		$V_{CC}=1.65V, V_{IN}=0V, I_{OUT}=4mA$		6.5	20.0	Ω
		$V_{CC}=1.65V, V_{IN}=1.65V, I_{OUT}=-4mA$		17.0	50.0	Ω
On Resistance Match Between Channel	ΔR_{ON}	$V_{CC}=4.5V, V_{BN}=3.15V, I_A=-30mA$		0.15		Ω
		$V_{CC}=3V, V_{BN}=2.1V, I_A=-24mA$		0.2		Ω
		$V_{CC}=2.3V, V_{BN}=1.6V, I_A=-8mA$		0.5		Ω
		$V_{CC}=1.65V, V_{BN}=1.15V, I_A=-4mA$		0.5		Ω
Input Leakage Current	$I_{I(LEAK)}$	$V_{CC}=0$ to $5.5V, 0 \leq V_{IN} \leq 5.5V$			±0.1	μA
Off State Leakage Current	I_{OFF}	$V_{CC}=1.65$ to $5.5V, 0 \leq A, B \leq V_{CC}$			±0.1	μA
Quiescent Supply Current	I_Q	$V_{CC}=5.5V, V_{IN}=V_{CC}$ or GND, $I_{OUT}=0$			1	μA
Analog Signal Range		$V_{CC}=V_{CC}, V_{IN}=V_{CC}$ or GND	0		V_{CC}	V

■ SWITCHING CHARACTERISTICS (see TEST CIRCUIT AND WAVEFORMS)

PARAMETER	SYMBOL	TEST CONDITIONS	MIN	TYP	MAX	UNIT
Propagation Delay Bus to Bus(Note)	t_{PLH} t_{PHL}	$C_L=50\text{ pF}$, $R_L=500\Omega$	$V_{CC}=1.65 \sim 1.95\text{V}$		3.5	ns
			$V_{CC}=2.3 \sim 2.7\text{V}$		1.2	ns
			$V_{CC}=3.0 \sim 3.6\text{V}$		0.8	ns
			$V_{CC}=4.5 \sim 5.5\text{V}$		0.3	ns
Output Enable Time Turn-On Time (A to B _N)	t_{PZL} t_{PZH}	$C_L=50\text{ pF}$, $R_L=500\Omega$	$V_{CC}=1.65 \sim 1.95\text{V}$	7.0	23.0	ns
			$V_{CC}=2.3 \sim 2.7\text{V}$	3.5	13.0	ns
			$V_{CC}=3.0 \sim 3.6\text{V}$	2.5	6.9	ns
			$V_{CC}=4.5 \sim 5.5\text{V}$	1.7	5.2	ns
Output Enable Time Turn-Off Time (A to B _N)	t_{PHZ} t_{PLZ}	$C_L=50\text{ pF}$, $R_L=500\Omega$	$V_{CC}=1.65 \sim 1.95\text{V}$	3.0	12.5	ns
			$V_{CC}=2.3 \sim 2.7\text{V}$	2.0	7.0	ns
			$V_{CC}=3.0 \sim 3.6\text{V}$	1.2	5.0	ns
			$V_{CC}=4.5 \sim 5.5\text{V}$	0.8	3.5	ns

Note: Guaranteed by design.

■ DYNAMIC CHARACTERISTICS ($T_A=25^\circ\text{C}$, unless otherwise specified)

PARAMETER	SYMBOL	TEST CONDITIONS	MIN	TYP	MAX	UNIT
Bandwidth	BW	$R_L=50\Omega$, Switch ON	$V_{CC}=1.8\text{V}$		220	MHz
			$V_{CC}=2.3\text{V}$		220	MHz
			$V_{CC}=3.0\text{V}$,		220	MHz
			$V_{CC}=4.5\text{V}$		220	MHz
OFF Isolation	O_{ISO}	$R_L=50\Omega$, $f=10\text{MHz}$, Switch OFF	$V_{CC}=1.8\text{V}$,		-60	dB
			$V_{CC}=2.3\text{V}$		-65	dB
			$V_{CC}=3.0\text{V}$		-65	dB
			$V_{CC}=4.5\text{V}$		-65	dB
Crosstalk	X_{TALK}	$R_L=50\Omega$, $f=10\text{MHz}$, Switch ON	$V_{CC}=1.8\text{V}$		-66	dB
			$V_{CC}=2.3\text{V}$		-66	dB
			$V_{CC}=3.0\text{V}$		-66	dB
			$V_{CC}=4.5\text{V}$		-66	dB
Total Harmonic Distortion	THD	$R_L=600\Omega$, $C_L=50\text{pF}$, $f=600\text{Hz} \sim 20\text{KHz}$	$V_{CC}=1.8\text{V}$		0.015	%
			$V_{CC}=2.3\text{V}$		0.025	%
			$V_{CC}=3.0\text{V}$		0.015	%
			$V_{CC}=4.5\text{V}$		0.01	%

■ OPERATING CHARACTERISTICS ($T_A=25^\circ\text{C}$)

PARAMETER	SYMBOL	TEST CONDITIONS	MIN	TYP	MAX	UNIT
Control Pin Input Capacitance	C_{IN}	$V_{CC}=0\text{V}$		2.3		pF
B Port Off Capacitance	C_{IO-B}	$V_{CC}=5.0\text{V}$		6.5		pF
A Port Capacitance When Switch Is Enabled	C_{IOA-ON}	$V_{CC}=5.0\text{V}$		18.5		pF

■ TEST CIRCUIT AND WAVEFORMS

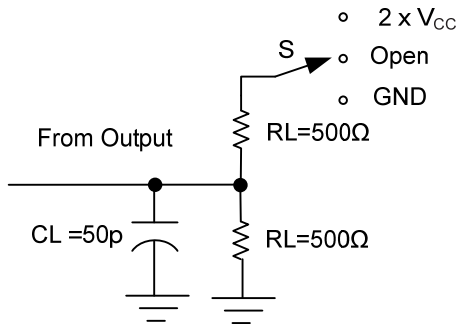

TEST CIRCUIT

TEST	S
t_{PLH}/t_{PHL}	Open
t_{PHZ}/t_{PZH}	GND
t_{PLZ}/t_{PZL}	$2 \times V_{CC}$

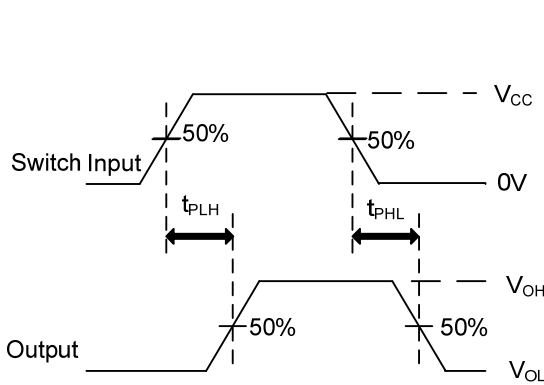

VOLTAGE WAVEFORMS
PROPAGATION DELAY TIMES

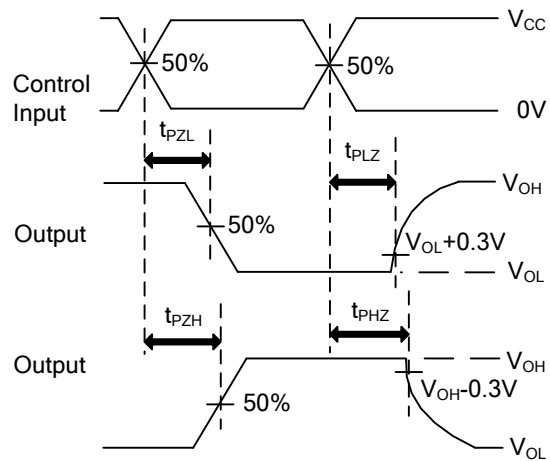

VOLTAGE WAVEFORMS
ENABLE AND DISABLE TIMES

Note: C_L includes probe and jig capacitance.
 $PRR \leq 1\text{MHz}$, $Z_0 = 50\Omega$, $t_R \leq 2.5\text{ns}$, $t_F \leq 2.5\text{ns}$.

UTC assumes no responsibility for equipment failures that result from using products at values that exceed, even momentarily, rated values (such as maximum ratings, operating condition ranges, or other parameters) listed in products specifications of any and all UTC products described or contained herein. UTC products are not designed for use in life support appliances, devices or systems where malfunction of these products can be reasonably expected to result in personal injury. Reproduction in whole or in part is prohibited without the prior written consent of the copyright owner. The information presented in this document does not form part of any quotation or contract, is believed to be accurate and reliable and may be changed without notice.