



## PA4871

CMOS IC

### 1.1W AUDIO POWER AMPLIFIER WITH SHUTDOWN MODE

#### DESCRIPTION

As a mono bridged power amplifier which is operating on a single 5V supply, the UTC **PA4871** is capable of delivering 1.1W of output power per channel into 8Ω loads with less than 0.5% THD+N.

The UTC **PA4871** is optimally suited for low-power portable applications because of the it do not require output coupling capacitors, bootstrap capacitors or snubber networks.

By using external gain-setting resistors, the closed loop response of the unity-gain stable **PA4871** can be configured.

#### FEATURES

- \* Output power at 0.5% THD+N  
Supply voltage:5V  
Delivering 1.1W into a 8Ω load
- \* With shutdown mode
- \* Stable unity-gain.

#### ORDERING INFORMATION

Ordering Number	Package	Packing
PA4871G-S08-R	SOP-8	Tape Reel
PA4871G-S08-T	SOP-8	Tube
PA4871G-SM1-R	MSOP-8	Tape Reel
PA4871G-SM1-T	MSOP-8	Tube
PA4871G-K08-3030-R	DFN-8(3×3)	Tape Reel

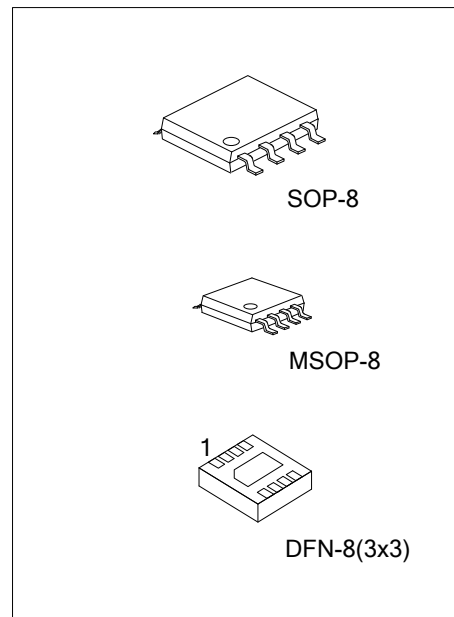

<p>PA4871G-K08-3030-R</p> <p>(1) Packing Type (2) Package Type (3) Green Package</p>	<p>(1) R: Tape Reel, T: Tube (2) K08-3030: DFN-8, S08: SOP-8, SM1: MSOP-8 (3) G: Halogen Free and Lead Free</p>
--	---

## MARKING

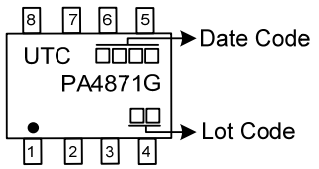
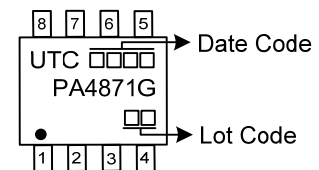
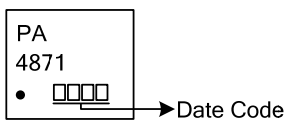
Package	MARKING
SOP-8	
MSOP-8	
DFN-8(3x3)	

## PIN CONFIGURATION

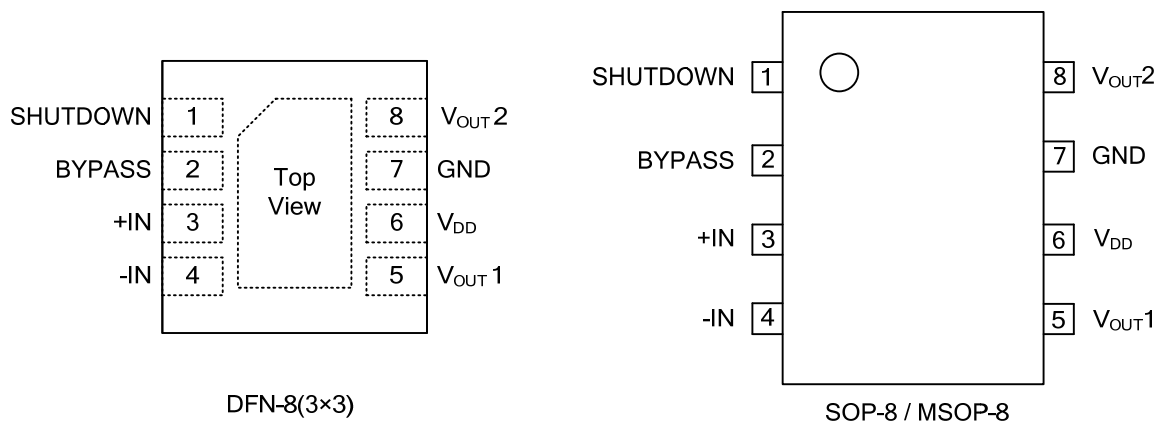

## PIN DESCRIPTION

PIN NO	PIN NAME	DESCRIPTION
1	SHUTDOWN	Shutdown control input pin.
2	BYPASS	Connected to a bypass capacitor.
3	+IN	+ pin of input signal.
4	-IN	- pin of input signal.
5	V <sub>OUT1</sub>	Output pin1
6	V <sub>DD</sub>	Supply voltage
7	GND	GND
8	V <sub>OUT2</sub>	Output pin2

## ■ BLOCK DIAGRAM

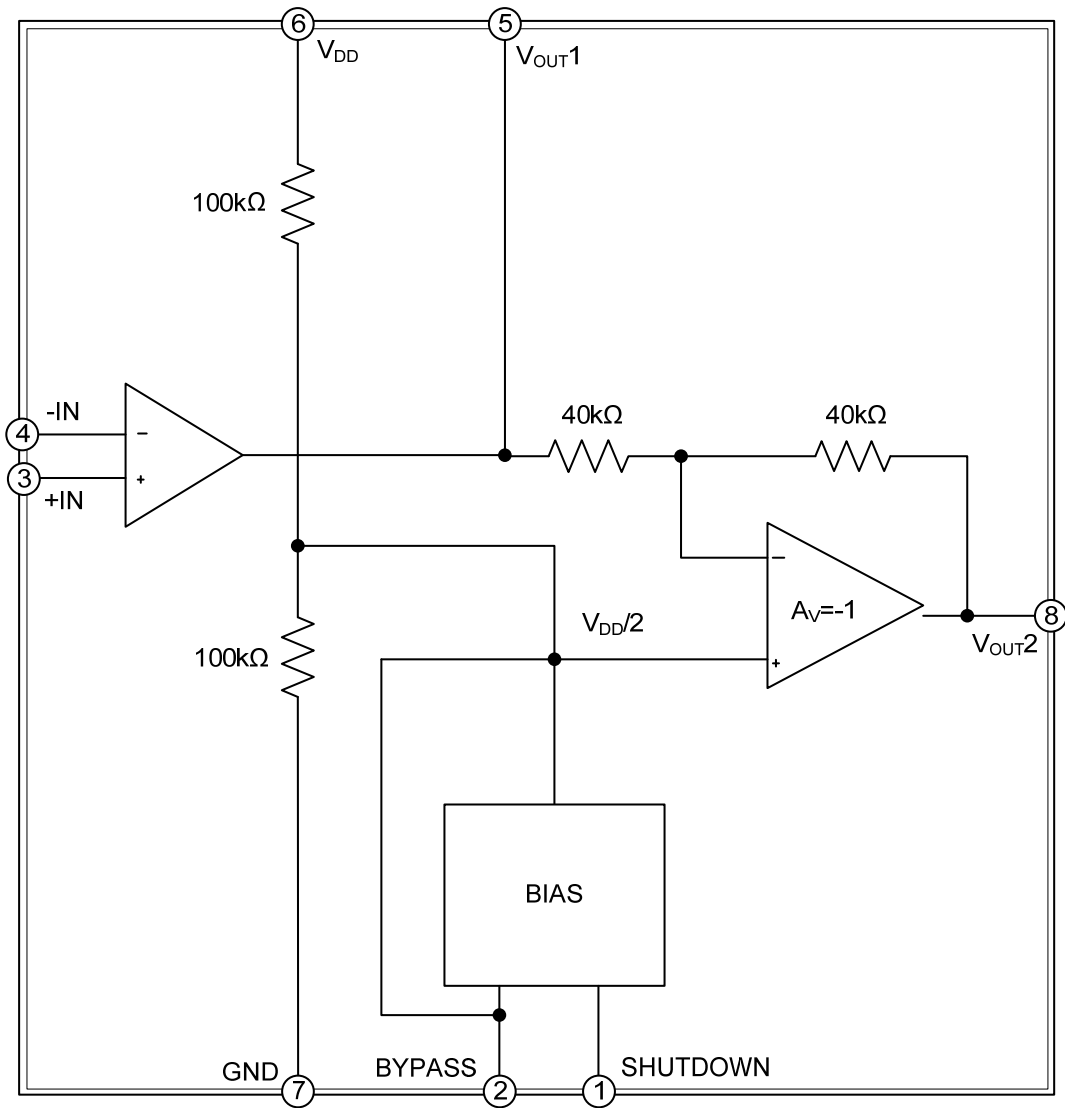

### ■ ABSOLUTE MAXIMUM RATING

PARAMETER	SYMBOL	RATINGS	UNIT
Supply Voltage	$V_{DD}$	6	V
Input Voltage	$V_{IN}$	$-0.3 \sim V_{DD} + 0.3$	V
Power Dissipation	$P_D$	Internally Limited	W
Junction Temperature	$T_J$	150	°C
Operating Temperature	$T_{OPR}$	$-40 \sim +85$	°C
Storage Temperature	$T_{STG}$	$-65 \sim +150$	°C

Note: Absolute maximum ratings are those values beyond which the device could be permanently damaged.

Absolute maximum ratings are stress ratings only and functional device operation is not implied.

### ■ THERMAL DATA

PARAMETER	SYMBOL	RATINGS	UNIT
Junction to Ambient	SOP-8/MSOP-8	140	°C/W
	DFN-8(3×3)	59	°C/W
Junction to Case	SOP-8/MSOP-8	35	°C/W
	DFN-8(3×3)	4.3 (Note)	°C/W

Note: Surface mounted on 1 in<sup>2</sup> copper pad of FR4 board

### ■ ELECTRICAL CHARACTERISTICS ( $T_A=25^\circ\text{C}$ , $V_{DD}=5\text{V}$ , $R_L=8\Omega$ , unless otherwise specified)

PARAMETER	SYMBOL	TEST CONDITIONS	MIN	TYP	MAX	UNIT
<b>DC ELECTRICAL CHARACTERISTICS</b>						
Supply Voltage	$V_{DD}$		2.0	5	5.5	V
DC Differential Output Voltage	$V_{OUT(DIFF)}$	$V_{IN}=0\text{V}$		5	50	mV
Supply Current	Mute Mode	$V_{IN}=0\text{V}, I_{OUT}=0\text{A}$		6.5	10.0	mA
	Shutdown Mode	$V_{PIN1}=V_{DD}$		0.6	2	μA
Output Power	$P_{OUT}$	THD=0.5%, $f_{IN}=1\text{kHz}$	1.0	1.10		W
		THD=10%, $f_{IN}=1\text{kHz}$		1.5		W
Total Harmonic Distortion+Noise	THD+N	$P_{OUT}=1\text{W}_{RMS}$ , $20\text{Hz} < f_{IN} < 20\text{kHz}$ , $G=2\text{V/V}$		0.25		%
Power Supply Ripple Rejection	PSRR	$V_{DD}=4.9\text{V to } 5.1\text{V}$		65		dB

## ■ TYPICAL APPLICATION CIRCUIT

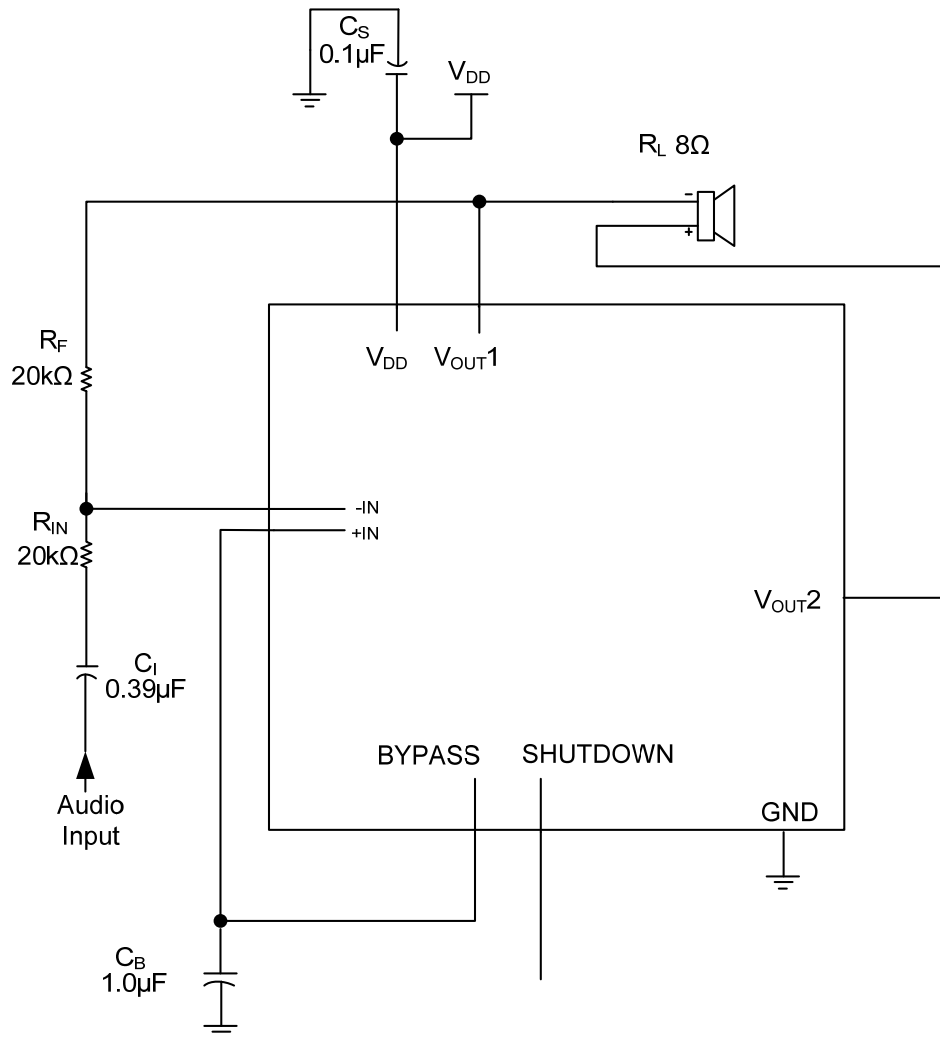

■ TYPICAL CHARACTERISTICS

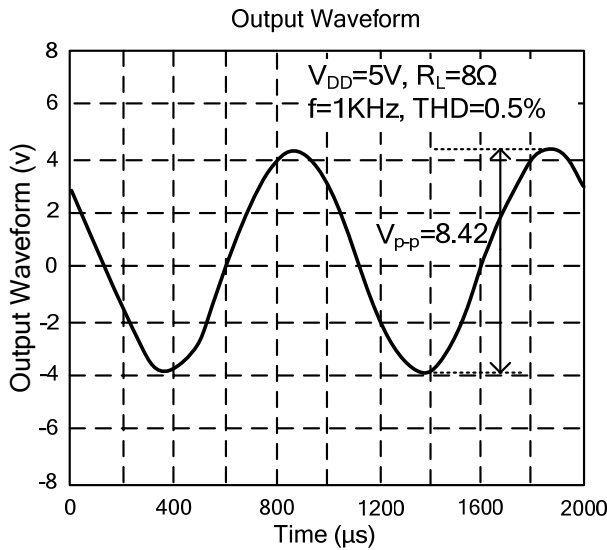
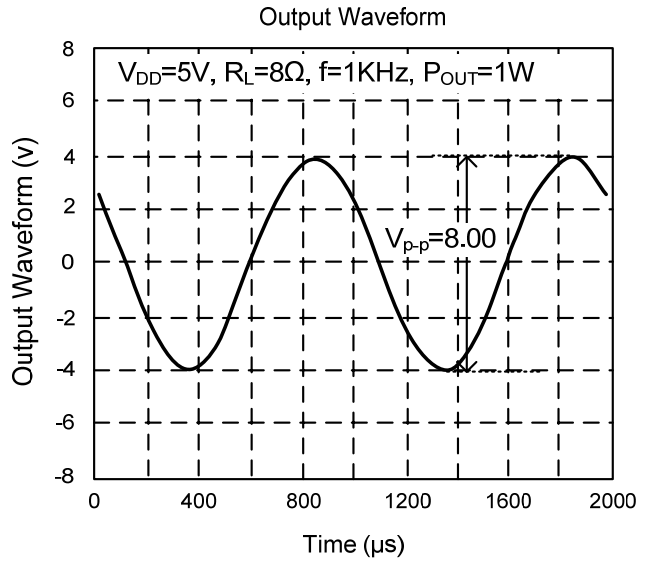
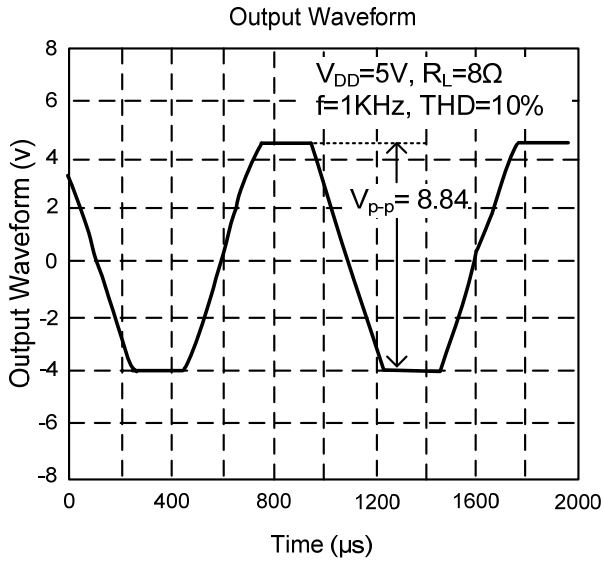

UTC assumes no responsibility for equipment failures that result from using products at values that exceed, even momentarily, rated values (such as maximum ratings, operating condition ranges, or other parameters) listed in products specifications of any and all UTC products described or contained herein. UTC products are not designed for use in life support appliances, devices or systems where malfunction of these products can be reasonably expected to result in personal injury. Reproduction in whole or in part is prohibited without the prior written consent of the copyright owner. The information presented in this document does not form part of any quotation or contract, is believed to be accurate and reliable and may be changed without notice.