



LR3XXYYB

CMOS IC

150mA 2CH LDO REGULATOR

DESCRIPTION

The UTC **LR3XXYYB** are CMOS voltage regulator ICs that have high output voltage accuracy, low dropout, low supply current, and high ripple rejection. Every voltage regulator IC of UTC **LR3XXYYB** series consists of an error amplifier, a voltage reference unit, a current limit circuit, resistors for setting output voltage, and a chip enable circuit.

Due to built-in transistor with low ON resistance and a chip enable function these ICs perform with low dropout voltage prolongs the battery life of each system. The load transient response and line transient response of the UTC **LR3XXYYB** Series are excellent, so these ICs are suitable for hand-held communication equipment power supply.

FEATURES

- * Low supply current: Typ. 60 μ A
- * Standby mode: Typ. 0.1 μ A
- * Low dropout voltage
- * High ripple rejection
- * Low temperature-drift coefficient of output voltage
- * Excellent line regulation
- * High output voltage accuracy
- * Output voltage stepwise setting with a step of 0.1V in the range of 1.5V ~ 3.3V is possible
- * Built-in fold-back protection circuit Typ. 40mA (current at short mode)
- * Ceramic capacitor is recommended. (1.0 μ F or more)

ORDERING INFORMATION

Ordering Number	Package	Packing
LR3XXYYBG-AG6-R	SOT-26	Tape Reel

Note: XXYY: Output Voltage, refer to Marking Information.

LR3XXYYBG-AG6-R		
(1) Packing Type	(1) R: Tape Reel	
(2) Package Type	(2) AG6: SOT-26	
(3) Green Package	(3) G: Halogen Free and Lead Free	
(4) Voltage Code at V _{OUTY}	(4) XX: refer to Marking Information	
(5) Voltage Code at V _{OUTX}	(5) YY: refer to Marking Information	

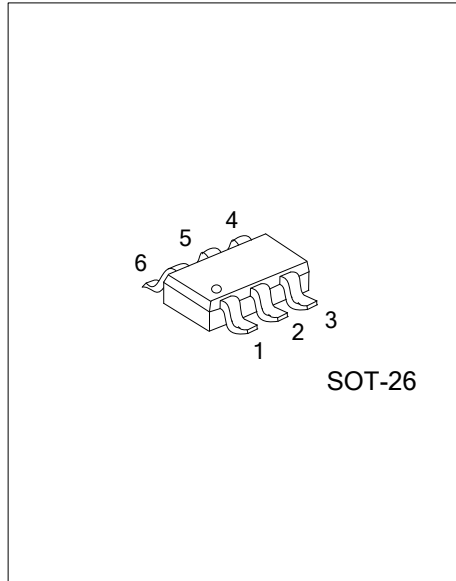

MARKING INFORMATIONS

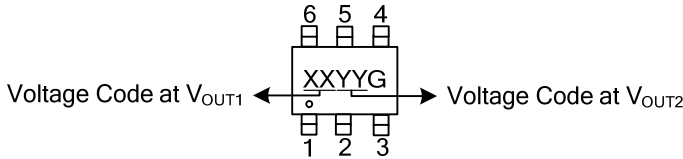
PACKAGE	VOLTAGE CODE		MARKING
	XX	YY	
SOT-26	12:1.2V	18:1.8V	
	12:1.2V	28:2.8V	
	15:1.5V	30:3.0V	
	15:1.5V	28:2.8V	
	15:1.5V	33:3.3V	
	18:1.8V	12:1.2V	
	18:1.8V	25:2.5V	
	18:1.8V	28:2.8V	
	18:1.8V	30:3.0V	
	18:1.8V	33:3.3V	
	28:2.8V	12:1.2V	
	28:2.8V	15:1.5V	
	28:2.8V	18:1.8V	
	28:2.8V	33:3.3V	
	33:3.3V	15:1.5V	
	33:3.3V	18:1.8V	
33:3.3V	28:2.8V		
33:3.3V	33:3.3V		

PIN CONFIGURATIONS

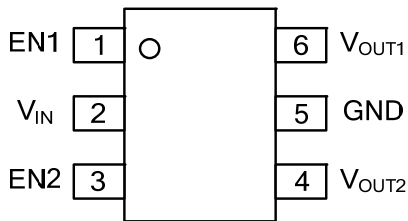

PIN DESCRIPTION

PIN NO.	PIN NAME	DESCRIPTION
1	EN1	Channel 1's output enable control Pin
2	V _{IN}	Voltage Input pin
3	EN2	Channel 2's output enable control Pin
4	V _{OUT2}	Channel 2's voltage output
5	GND	Ground
6	V _{OUT1}	Channel 1's voltage output

■ BLOCK DIAGRAM

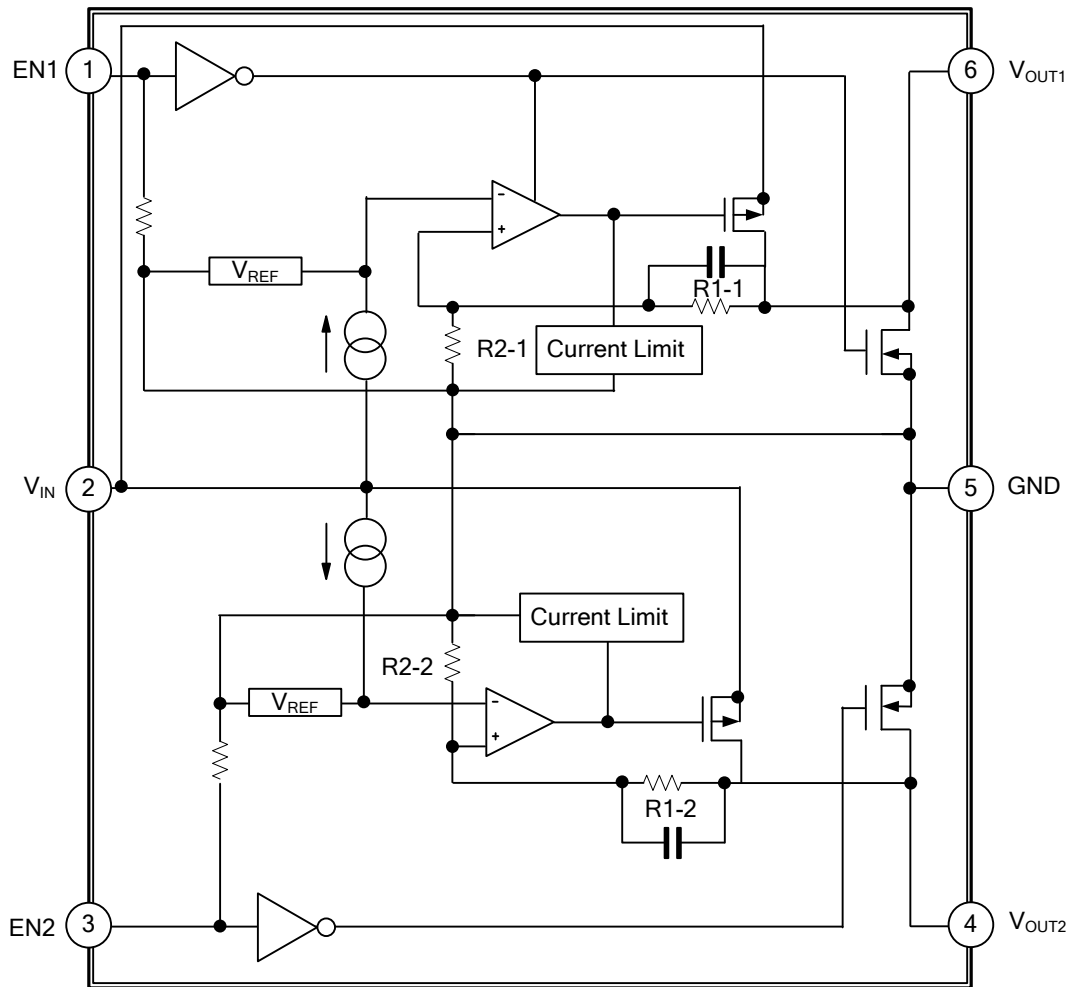

■ ABSOLUTE MAXIMUM RATINGS

PARAMETER	SYMBOL	RATINGS	UNIT
Input Voltage	V_{IN}	6.5	V
Input Voltage (EN)	V_{EN}	6.5	V
Output Voltage	V_{OUT}	-0.3 ~ $V_{IN} + 0.3$	V
Output Current	I_{OUT1+} I_{OUT2}	700	mA
Power Dissipation	P_D	420	mW
Operating Temperature	T_{OPR}	-40 ~ +85	°C
Storage Temperature	T_{STG}	-55 ~ +125	°C

Note: Absolute maximum ratings are those values beyond which the device could be permanently damaged. Absolute maximum ratings are stress ratings only and functional device operation is not implied.

■ THERMAL DATA

PARAMETER	SYMBOL	RATING	UNIT
Junction to Ambient	θ_{JA}	250	°C/W

■ ELECTRICAL CHARACTERISTICS

PARAMETER	SYMBOL	TEST CONDITIONS	MIN	TYP	MAX	UNIT
Output Voltage	V_{OUT}	$V_{IN} = \text{Set } V_{OUT} + 1V, 1mA \leq I_{OUT} \leq 30mA$	$V_{OUT} \times 0.98$		$V_{OUT} \times 1.02$	V
Output Current	I_{OUT}	$V_{IN} - V_{OUT} = 1.0V$	150			mA
Load Regulation	ΔV_{LOAD}	$V_{IN} = \text{Set } V_{OUT} + 1V, 1mA \leq I_{OUT} \leq 150mA$		15	40	mV
Line Regulation	ΔV_{LINE}	Set $V_{OUT} + 0.5V \leq V_{IN} \leq 6.0V, I_{OUT} = 30mA$		0.02	0.10	%/V
Dropout Voltage	V_D	Refer to the Electrical Characteristics by Output Voltage				
Supply Current	I_{SS}	$V_{IN} = \text{Set } V_{OUT} + 1V$ (Both LDOs)		90	120	μA
Supply Current (Standby)	I_{STN-BY}	$V_{IN} = \text{Set } V_{OUT} + 1V, V_{CE} = GND$		0.1	1.0	μA
Power Supply Ripple Rejection	PSRR	Ripple 0.5Vp-p, $V_{IN} = \text{Set } V_{OUT} + 1V$ $I_{OUT} = 30mA$ (In case that $V_{OUT} \leq 1.7V$, $V_{IN} = \text{Set } V_{OUT} + 1.2V$)		75 ^(Note1) 65 ^(Note2)		dB
Input Voltage	V_{IN}		2.0		6.0	V
Output Voltage Temperature Coefficient	$\frac{\Delta V_{OUT}}{\Delta T_{OPR}}$	$I_{OUT} = 30mA, -40^\circ C \leq T_{OPR} \leq 85^\circ C$		± 100		ppm / °C
Short Current Limit	$I_{SC(LIMIT)}$	$V_{OUT} = 0V$		40		mA
Pull-Down Resistance for EN Pin	R_{PD}		0.7	2.0	8.0	M Ω
EN Input Voltage "H"	V_{CEH}		1.5			V
EN Input Voltage "L"	V_{CEL}				0.3	V
Output Noise	eN	BW=10Hz ~ 100kHz		30		μV_{rms}
Low Output Nch Tr. ON Resistance (of B version)	R_{LOW}	$V_{CE} = 0V$		60		Ω

Notes: 1. f=1kHz, 70dB as to $V_{OUT} \geq 2.5V$ Output type
2. f=10kHz, 60dB as to $V_{OUT} \geq 2.5V$ Output type

■ ELECTRICAL CHARACTERISTICS BY OUTPUT VOLTAGE

Output Voltage V_{OUT} (V)	Dropout Voltage, V_D (V)		
	CONDITION	TYP	MAX
$V_{OUT} = 1.2$	$I_{OUT} = 150mA$	0.40	0.75
$V_{OUT} = 1.5$		0.38	0.70
$V_{OUT} = 1.6$		0.35	0.65
$V_{OUT} = 1.7$		0.33	0.60
$1.8 \leq V_{OUT} \leq 2.0$		0.32	0.55
$2.1 \leq V_{OUT} \leq 2.7$		0.28	0.50
$2.8 \leq V_{OUT} \leq 3.3$		0.22	0.35

■ TEST CIRCUITS

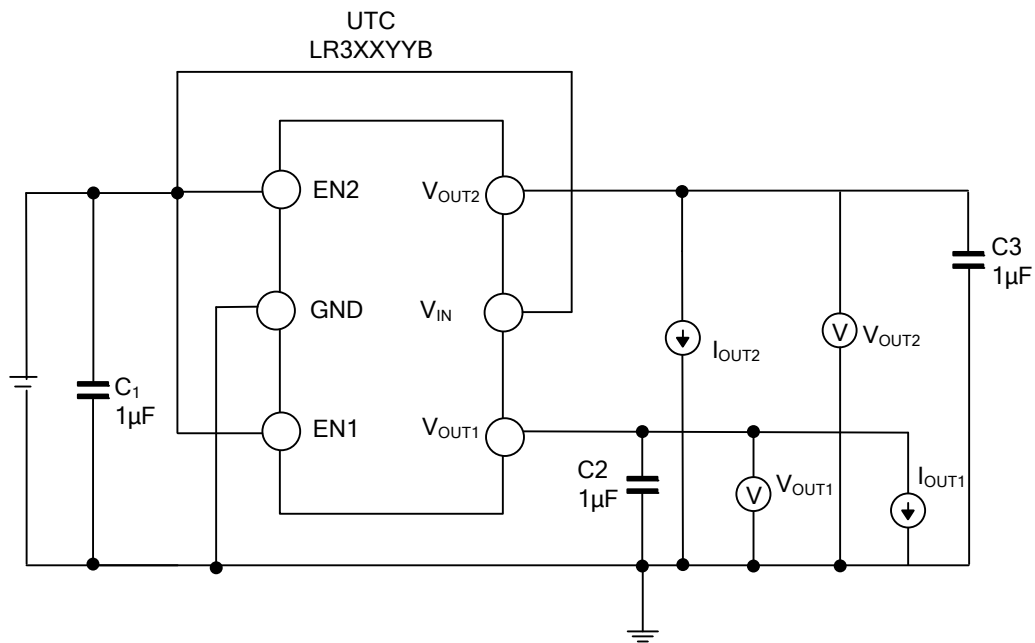

Fig.1 Standard Test Circuit

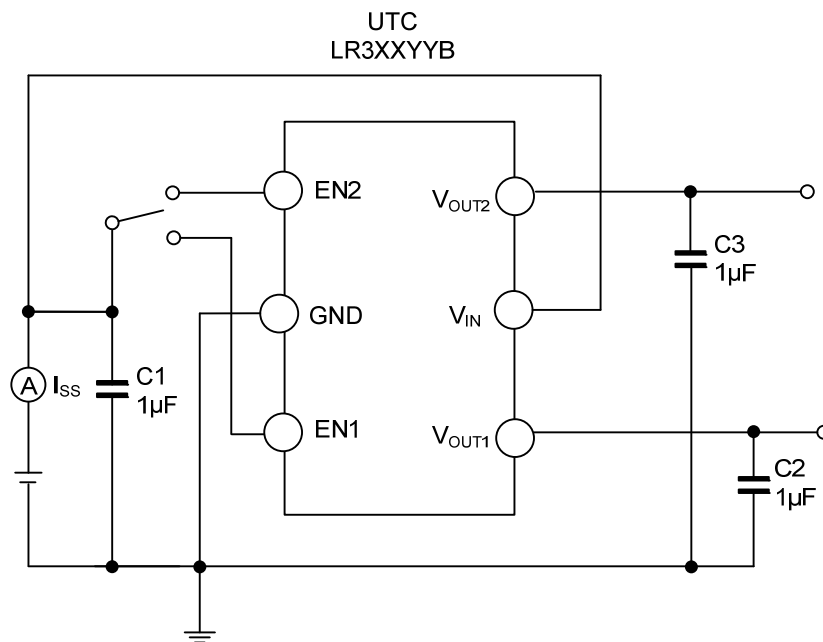

Fig.2 Supply Current Test Circuit

■ TEST CIRCUITS(Cont.)

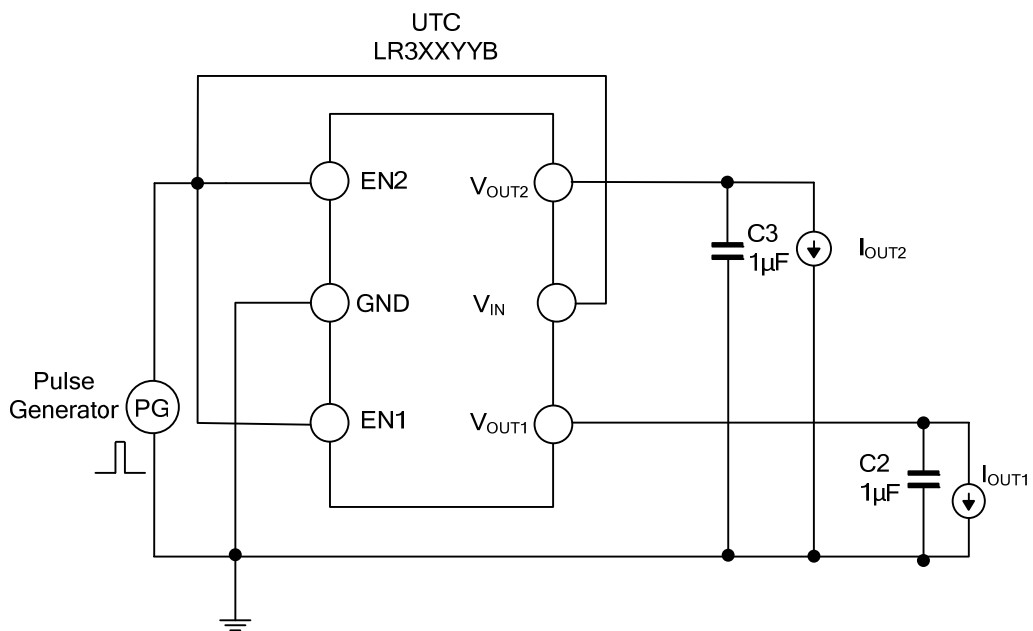

Fig.3 Ripple Rejection, Line Transient Response Test Circuit

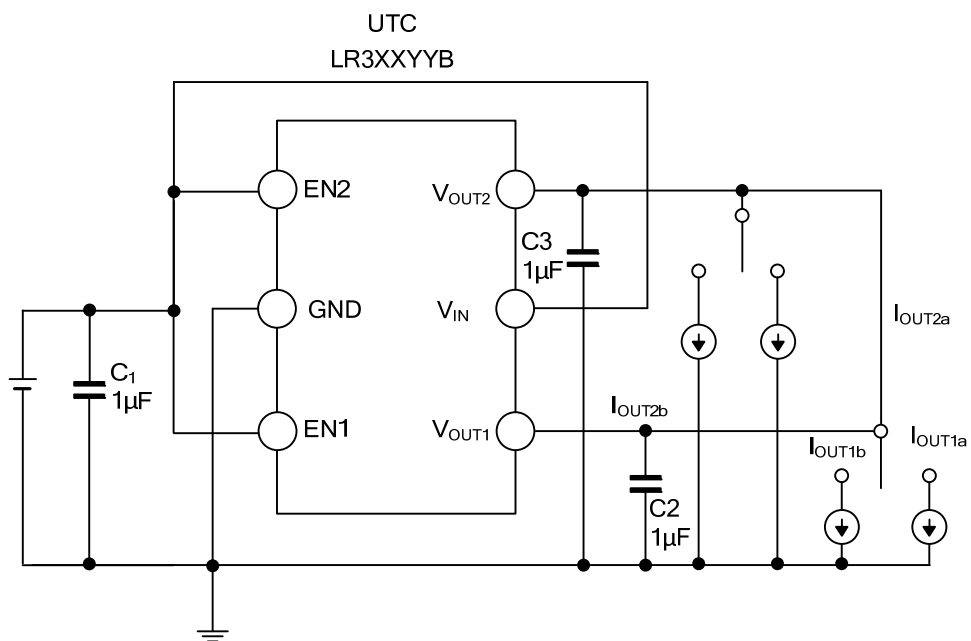
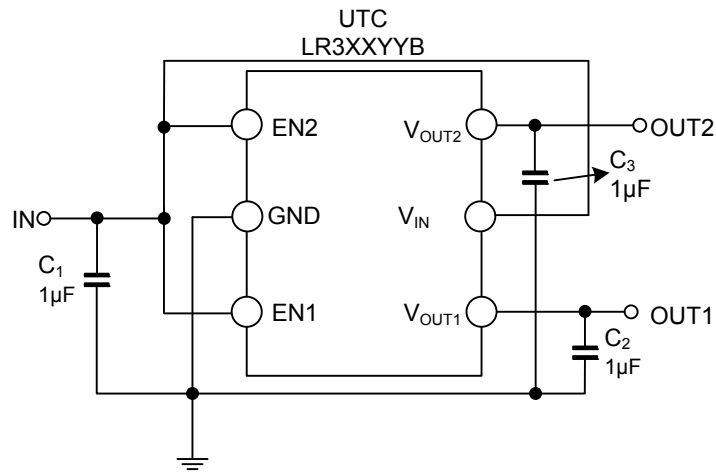
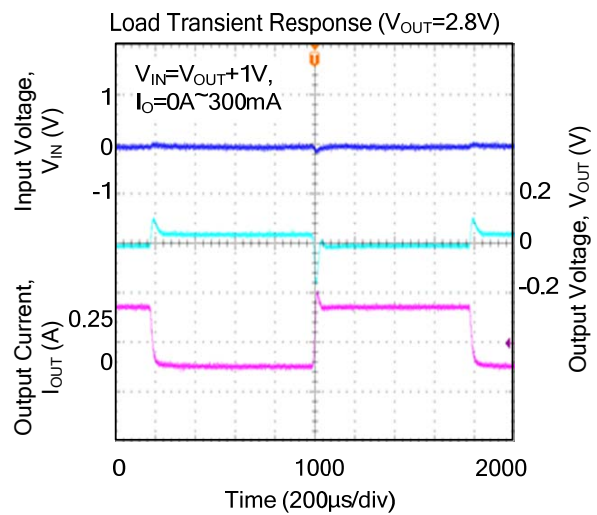
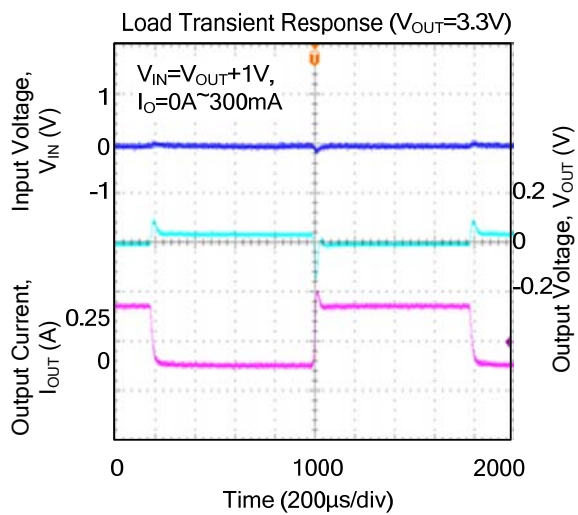
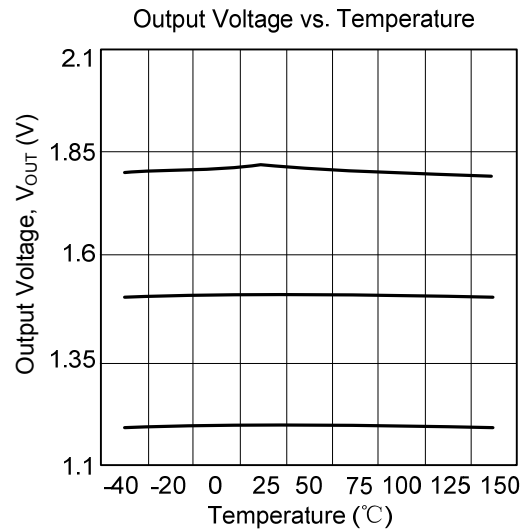
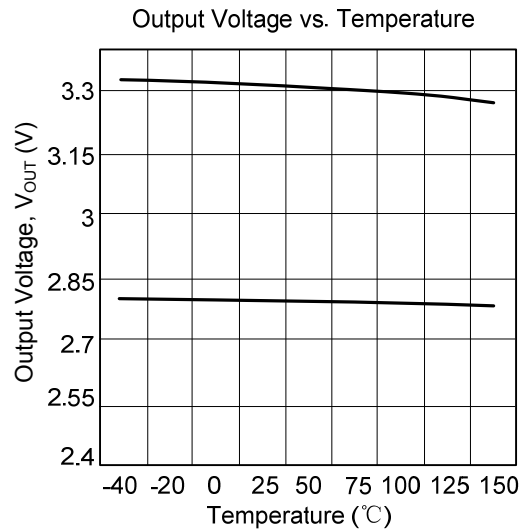

Fig.4 Load Transient Response Test Circuit

■ TYPICAL APPLICATION CIRCUIT



TYPICAL CHARACTERISTICS



UTC assumes no responsibility for equipment failures that result from using products at values that exceed, even momentarily, rated values (such as maximum ratings, operating condition ranges, or other parameters) listed in products specifications of any and all UTC products described or contained herein. UTC products are not designed for use in life support appliances, devices or systems where malfunction of these products can be reasonably expected to result in personal injury. Reproduction in whole or in part is prohibited without the prior written consent of the copyright owner. The information presented in this document does not form part of any quotation or contract, is believed to be accurate and reliable and may be changed without notice.