



ULE4275

Preliminary

LINEAR INTEGRATED CIRCUIT

5-V LOW-DROPOUT VOLTAGE REGULATOR

DESCRIPTION

The UTC **ULE4275** is a monolithic integrated low-dropout voltage regulator. The device regulates an input voltage up to 45V to $V_{OUT} = 5V$ (typical). The device can drive loads up to 450mA. It also provides overcurrent protection and overtemperature protection for control of the state of the output voltage. The device generates a reset signal for an output voltage, $V_{OUT,rt}$ of 4.65V (typical). By the use of an external delay capacitor, one can program the reset delay time.

The input capacitor, C_{IN} , compensates for line fluctuation. Using a resistor of approximately 1Ω in series with C_{IN} dampens the oscillation of input inductance and input capacitance. The output capacitor, C_{OUT} , stabilizes the regulation circuit. The specification for stability is at $C_{OUT} \geq 22\mu F$ and $ESR \leq 5\Omega$, within the operating temperature range. Stability for electrolytic capacitors specifically is at $C_{OUT} \geq 68\mu F$ within the operating temperature range.

The control amplifier compares a reference voltage to a voltage that is proportional to the output voltage and drives the base of the series transistor through a buffer. Saturation control as a function of the load current prevents any oversaturation of the power element. The device also incorporates a number of internal circuits for protection against: overload, overtemperature, and reverse polarity.

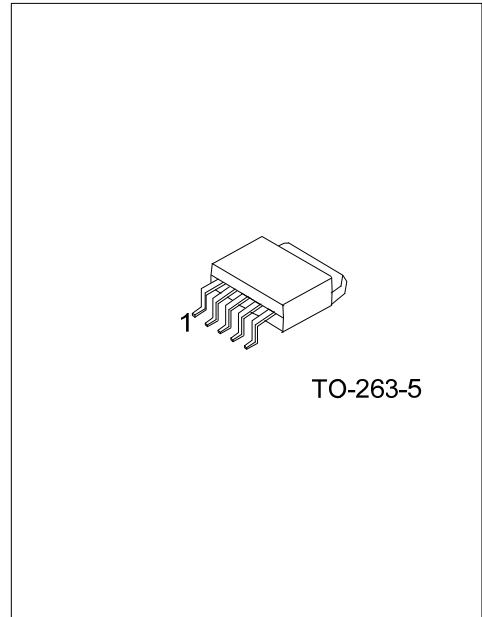

FEATURES

- * Qualified for Automotive Applications
- * Output Voltage $5V \pm 2\%$
- * Very Low Current Consumption
- * Power-On and Undervoltage Reset
- * Reset Low-Level Output Voltage $< 1V$
- * Very Low Dropout Voltage
- * Internal Short-Circuit Current Limiting
- * Reverse-Polarity Proof

ORDERING INFORMATION

Ordering Number		Package	Packing
Lead Free	Halogen Free		
ULE4275L-TQ5-T	ULE4275G-TQ5-T	TO-263-5	Tube
ULE4275L-TQ5-R	ULE4275G-TQ5-R	TO-263-5	Tape Reel

<p>ULE4275L-TQ5-T</p> <p>(1) Packing Type (2) Package Type (3) Green Package</p>	<p>(1) T: Tube, R: Tape Reel (2) TQ5: TO-263-5 (3) L: Lead Free, G: Halogen Free and Lead Free</p>
--	--

MARKING

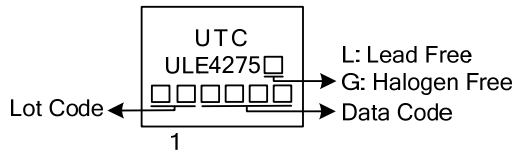

PIN CONFIGURATION

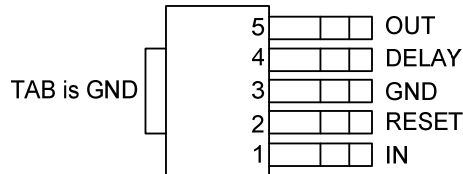

PIN DESCRIPTION

PIN NO.	PIN NAME	DESCRIPTION
1	IN	Input. Connect to ground as close to device as possible, through a ceramic capacitor.
2	RESET	Reset output. Open-collector output
3	GND	Ground. Internally connected to heatsink
4	DELAY	Reset delay. Connect to ground with a capacitor to set delay time.
5	OUT	Output. Connect to ground with $\geq 22\mu\text{F}$ capacitor, $\text{ESR} < 5\Omega$ at 10kHz.

BLOCK DIAGRAM

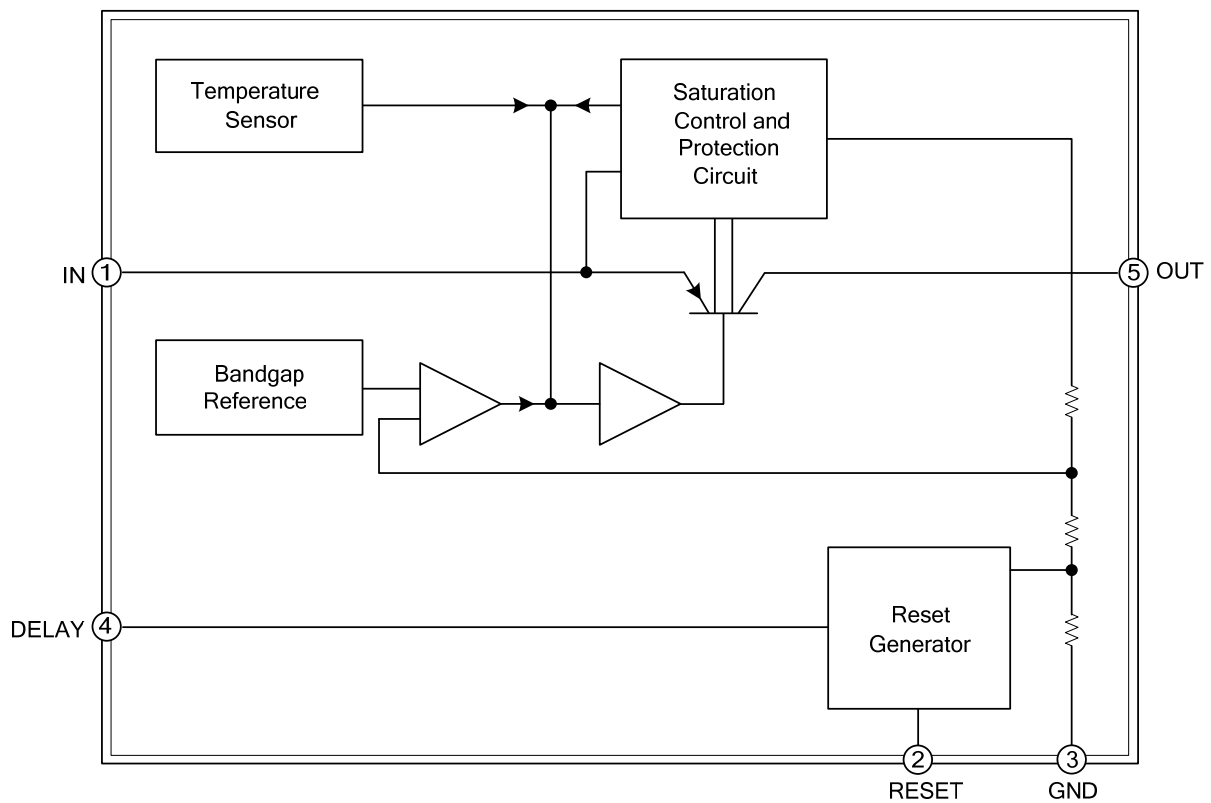

■ ABSOLUTE MAXIMUM RATING (over operating free-air temperature range (unless otherwise noted))

PARAMETER		SYMBOL	RATINGS	UNIT
Input Voltage Range (Note 1)	IN	V_I	-42~45	V
	DELAY		-0.3~7	V
Output Voltage Range	OUT	V_O	-1~16	V
	RESET		-0.3~25	V
Input Current	DELAY	I_I	±2	mA
Output Current		I_O	±5	mA
Operating Junction Temperature		T_J	-40~150	°C
Storage Temperature		T_{STG}	-65~150	°C
Electrostatic Discharge	Human body model (HBM)	$V_{(ESD)}$	6000	V
	Machine model (MM)		400	V

Notes: 1. Absolute maximum ratings are those values beyond which the device could be permanently damaged.

Absolute maximum ratings are stress ratings only and functional device operation is not implied.

2. All voltage values are with respect to the network ground terminal.

■ RECOMMENDED OPERATING CONDITIONS

(over operating free-air temperature range (unless otherwise noted))

PARAMETER	SYMBOL	MIN	TYP	MAX	UNIT
Input Voltage	V_I	5.5		42	V
Junction Temperature	T_J	-40		150	°C

■ THERMAL RESISTANCES CHARACTERISTICS

PARAMETER	SYMBOL	RATINGS	UNIT
Junction-to-Ambient Thermal Resistance	θ_{JA}	32.8	°C/W
Junction-to-Case	θ_{JC}	38	°C/W

■ ELECTRICAL CHARACTERISTICS

(over recommended operating free-air temperature range, $V_I=13.5V$, $T_J=-40^{\circ}C\sim 150^{\circ}C$ (unless otherwise noted) (see Test Circuit))

PARAMETER	SYMBOL	TEST CONDITIONS	MIN	TYP	MAX	UNIT
Output Voltage	V_O	$I_O=5mA\sim 400mA$, $V_I=6V\sim 28V$	4.9	5	5.1	V
		$I_O=5mA\sim 200mA$, $V_I=6V\sim 40V$	4.9	5	5.1	V
Output Current Limit	I_O		350	700	950	mA
Current Consumption, $I_q=I_I-I_O$	I_q	$I_O=1mA$	$T_J=25^{\circ}C$	150	200	μA
			$T_J\leq 85^{\circ}C$	150	220	μA
		$I_O=250mA$		7.5	18	mA
		$I_O=400mA$		12	22	mA
Dropout Voltage (Note)	V_{DO}	$I_O=300mA$, $V_{DO}=V_I-V_O$		250	500	mV
Load Regulation		$I_O=5mA\sim 400mA$		15	30	mV
Line Regulation		$\Delta V_I=8V\sim 32V$, $I_O=5mA$	-15	5	15	mV
Power-Supply Ripple Rejection	PSRR	$f_r=100Hz$, $V_r=0.5V_{pp}$		60		dB
Temperature Output-Voltage Drift	$\frac{\Delta V_O}{\Delta T}$			0.5		mV/K
RESET Switching Threshold	$V_{O,rt}$		4.5	4.65	4.8	V
RESET Output Low Voltage	V_{ROL}	$R_{ext}\geq 5k\Omega$, $V_O>1V$		0.2	0.4	V
RESET Output Leakage Current	I_{ROH}	$V_{ROH}=5V$		0	10	μA
RESET Charging Current	$I_{D,c}$	$V_D=1V$	3	5.5	9	μA
RESET Upper Timing Threshold	V_{DU}		1.5	1.8	2.2	V
RESET Lower Timing Threshold	V_{DRL}		0.2	0.4	0.7	V

Note: Measured when the output voltage V_O has dropped 100 mV from the nominal value obtained at $V_I=13.5V$.

■ SWITCHING CHARACTERISTICS

(over operating free-air temperature range (unless otherwise noted) (see Figure 1))

PARAMETER	SYMBOL	TEST CONDITIONS	MIN	TYP	MAX	UNIT
RESET Delay Time	t_{rd}	$C_D=47nF$	10	16	22	ms
RESET Reaction Time	t_{rr}	$C_D=47nF$		0.5	2	μs

■ TIMING DIAGRAM

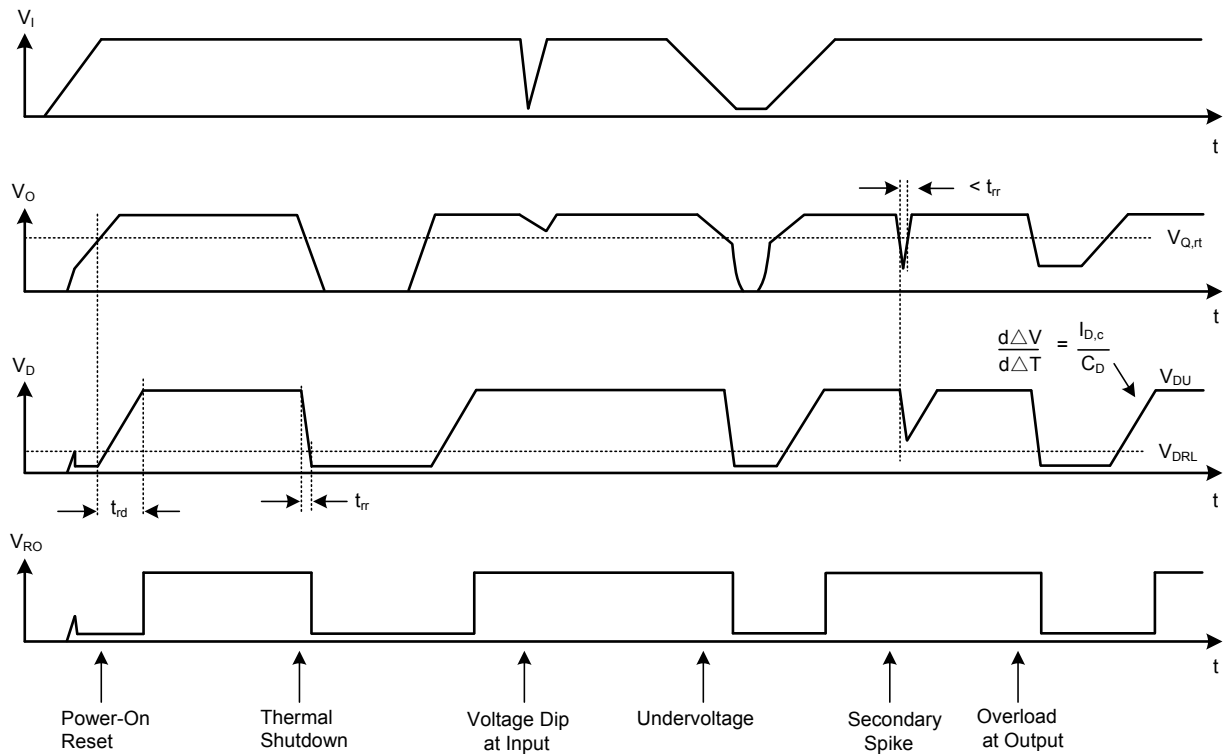
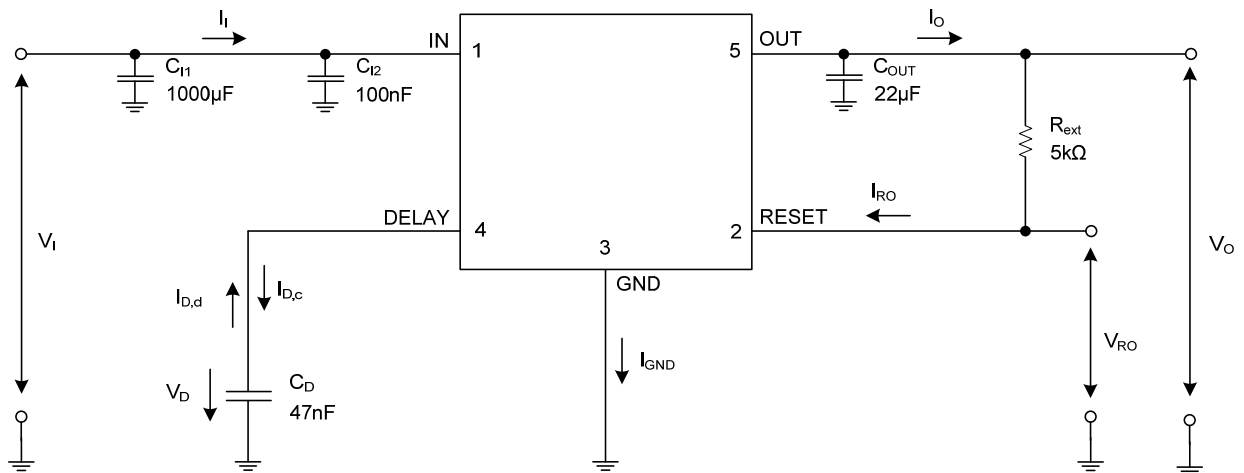
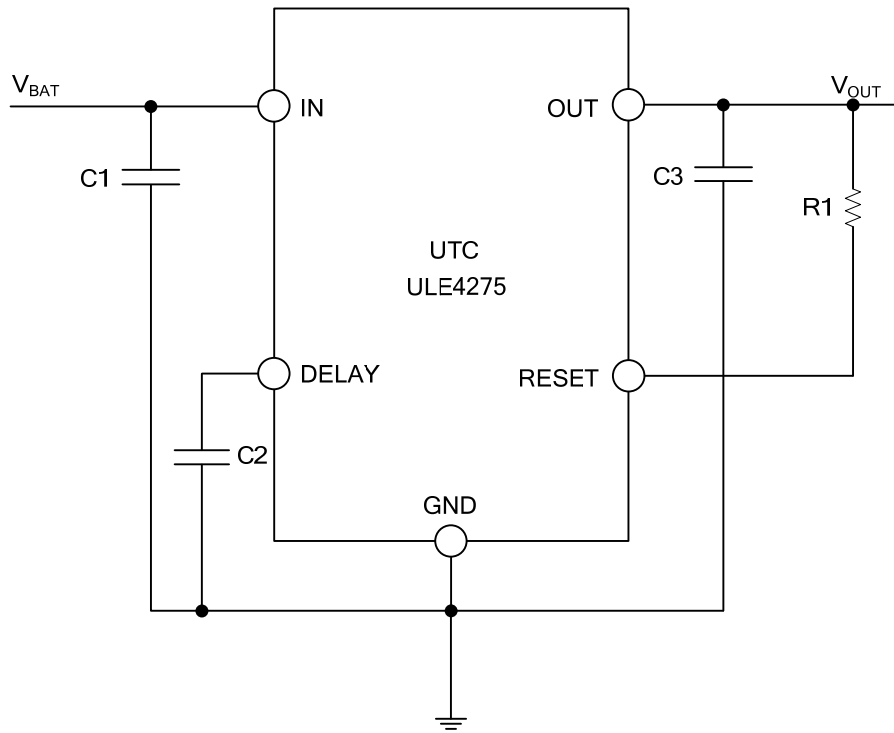

Figure 1. Reset Timing Diagram

■ TEST CIRCUIT



■ TYPICAL APPLICATION CIRCUIT



UTC assumes no responsibility for equipment failures that result from using products at values that exceed, even momentarily, rated values (such as maximum ratings, operating condition ranges, or other parameters) listed in products specifications of any and all UTC products described or contained herein. UTC products are not designed for use in life support appliances, devices or systems where malfunction of these products can be reasonably expected to result in personal injury. Reproduction in whole or in part is prohibited without the prior written consent of the copyright owner. The information presented in this document does not form part of any quotation or contract, is believed to be accurate and reliable and may be changed without notice.