



UCV676/A

LINEAR INTEGRATED CIRCUIT

400mA LOW-DROP VOLTAGE REGULATOR

DESCRIPTION

The UTC **UCV676/A** is a low dropout voltage regulator with a 400mA output current used in harsh automotive environments. It can be used in wide input voltage and operating temperature ranges.

It has a high peak input voltage tolerance and reverse input voltage protection. Built-in heat protection circuit, current limiting circuit and inhibit control circuit. The UTC **UCV676/A** family is available in TO-263-5 and TO-252-4 surface mount packages. The output is stable over a wide output capacitance and ESR range.

FEATURES

- * 2.5V and 1.8V $\pm 4\%$ Output Voltage
- * 3.3V, 5.0V, and Adjustable Voltage Version (from 2.5V~20V) $\pm 4\%$ or $\pm 2\%$ Output Voltage
- * 400mA Output Current
- * 500mV (max) Dropout Voltage (5.0V Output)
- * Inhibit control input
- * Very Low Current Consumption
- * Fault Protection
 - +45V Peak Transient Voltage
 - Overcurrent
 - Overheat

ORDERING INFORMATION

Ordering Number		Package	Packing
Lead Free	Halogen Free		
UCV676L-xx-TQ5-R	UCV676G-xx-TQ5-R	TO-263-5	Tape Reel
UCV676L-xx-TQ5-T	UCV676G-xx-TQ5-T	TO-263-5	Tube
UCV676L-xx-TN4-R	UCV676G-xx-TN4-R	TO-252-4	Tape Reel
UCV676L-xx-TN4-T	UCV676G-xx-TN4-T	TO-252-4	Tube
UCV676AL-xx-TQ5-R	UCV676AG-xx-TQ5-R	TO-263-5	Tape Reel
UCV676AL-xx-TQ5-T	UCV676AG-xx-TQ5-T	TO-263-5	Tube
UCV676AL-xx-TN4-R	UCV676AG-xx-TN4-R	TO-252-4	Tape Reel
UCV676AL-xx-TN4-T	UCV676AG-xx-TN4-T	TO-252-4	Tube

UCV676AL-xx-TN4-R 	(1) Packing Type (2) Package Type (3) Voltage Code (4) Lead Plating (5) Output Voltage	(1) T: Tube, R: Tape Reel (2) TN4: TO-252-4, TQ5: TO-263-5 (3) refer to MARKING INFORMATION (4) L: Lead Free, G: Halogen Free (5) Blank: 4%, A: 2%
-----------------------	--	--

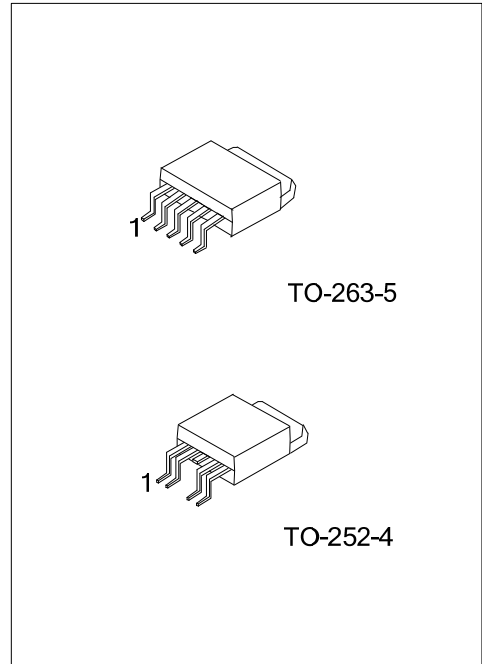

MARKING INFORMATION

PACKAGE	VOLTAGE CODE	MARKING
TO-252-4	18 : 1.8V 25 : 2.5V	
TO-263-5	33 : 3.3V 50 : 5.0V AD: ADJ	

PIN DESCRIPTION

PIN NO.	PIN NAME	DESCRIPTION
1	V _{IN}	Input; Power supply
2	INH	Inhibit; Set low-to inhibit
3	GND	Ground
4	NC/VA	Not connected for fixed voltage version / Voltage Adjust Input for adjustable voltage version; use an external voltage divider to set the output voltage
5	V _{OUT}	Output: Bypass with a capacitor to GND

■ BLOCK DIAGRAM

Fixed Voltage Version

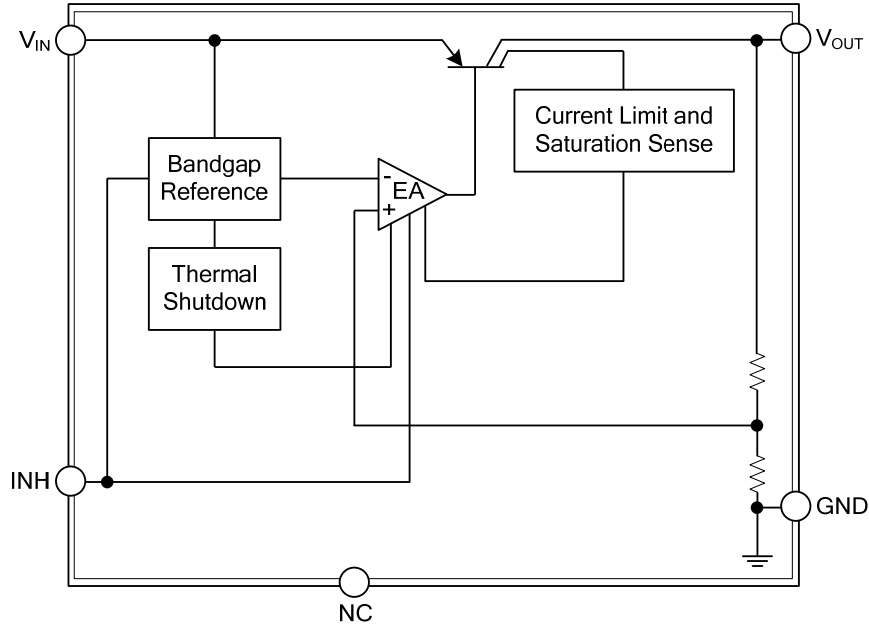

Adjustable Voltage Version

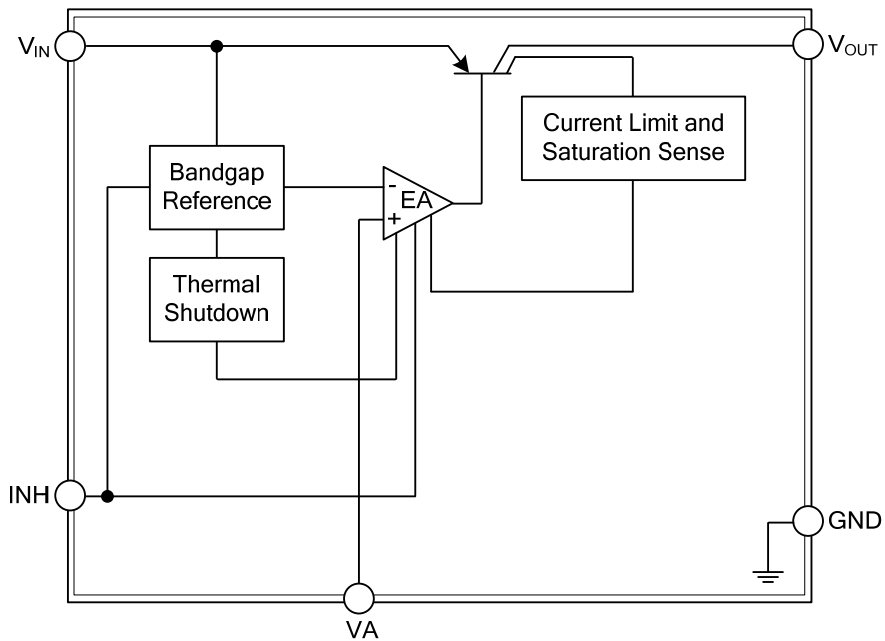

■ ABSOLUTE MAXIMUM RATING (Note 1)

PARAMETER	SYMBOL	RATINGS	UNIT
Input Voltage	V_{IN}	45	V
Input Peak Transient Voltage	V_{IN}	45	V
Inhibit INH Voltage	V_{INH}	45	V
Voltage Adjust Input VA	V_{VA}	10	V
Output Voltage	V_{OUT}	40	V
Ground Current	I_q	100	mA
Input Voltage Operating Range (Note 2)	V_I	$V_{OUT}+0.5V$ or $4.5V\sim 40$	V
Junction Temperature	T_J	-40~150	°C
Storage Temperature	T_{STG}	-50~150	°C

Notes: 1. Absolute maximum ratings are those values beyond which the device could be permanently damaged. Absolute maximum ratings are stress ratings only and functional device operation is not implied.
 2. During the voltage range which exceeds the maximum tested voltage of V_{IN} , operation is assured, but not specified. Wider limits may apply. Thermal dissipation must be observed closely.

■ ELECTRICAL CHARACTERISTICS ($V_{IN}=13.5V$, $T_J=25^\circ C$, unless otherwise noted.)

For UCV676-1.8

PARAMETER	SYMBOL	TEST CONDITIONS	UCV676			UNIT
			MIN	TYP	MAX	
OUTPUT						
Output Voltage	V_{OUT}	$5.0mA < I_{OUT} < 400mA$, $4.5V < V_{IN} < 28V$	1.728	1.8	1.872	V
		$5.0mA < I_{OUT} < 200mA$, $4.5V < V_{IN} < 40V$	1.728	1.8	1.872	V
Output Current Limitation	I_{OUT}	$V_{OUT}=90\% V_{OUT}(TYP)$	400	700	1100	mA
Quiescent Current (Sleep Mode)	I_q	$I_q=I_I-I_{OUT}$, $V_{INH}=0V$			10	μA
Quiescent Current	I_q	$I_q=I_I - I_{OUT}$	$I_{OUT}=1.0mA$	130	220	μA
			$I_{OUT}=250mA$	10	15	mA
			$I_{OUT}=400mA$	25	35	mA
Dropout Voltage	V_{DR}	$V_{IN}=4.5V$, $I_{OUT}=250mA$, $V_{DR}=V_{IN}-V_{OUT}$			2.772	V
Load Regulation	ΔV_{OUT}	$I_{OUT}=5.0mA\sim 400mA$		10	35	mV
Line Regulation	ΔV_{OUT}	$\Delta V_{IN}=12V\sim 32V$, $I_{OUT}=5.0mA$		2.5	25	mV
Power Supply Ripple Rejection	PSRR	$f_r=100Hz$, $V_r=0.5V_{RMS}$		60		dB
Temperature coefficient of V_{OUT}	$\Delta V_{OUT}/\Delta T$			0.5		mV/K
INHIBIT						
Inhibit Voltage, Output High	V_{INH}	$V_{OUT} \geq V_{OUT(MIN)}$		2.8	3.5	V
Inhibit Voltage, Output Low (Off)	V_{INH}	$V_{OUT} \leq 0.1V$	0.5	1.7		V
Input Current	I_{INH}	$V_{INH}=5.0V$	5.0	10	20	μA
THERMAL SHUTDOWN						
Thermal Shutdown Temperature (Note 2)	T_{SD}	$I_{OUT}=5.0mA$	150		210	°C

■ ELECTRICAL CHARACTERISTICS(Cont.)

For UCV676-2.5

PARAMETER	SYMBOL	TEST CONDITIONS	UCV676			UNIT	
			MIN	TYP	MAX		
OUTPUT							
Output Voltage	V_{OUT}	5.0mA< I_{OUT} <400mA, 4.5V< V_{IN} <28V	2.4	2.5	2.6	V	
		5.0mA< I_{OUT} <200mA, 4.5V< V_{IN} <40V	2.4	2.5	2.6	V	
Output Current Limitation	I_{OUT}	$V_{OUT}=90\% V_{OUT(TYP)}$	400	700	1100	mA	
Quiescent Current (Sleep Mode)	I_q	$I_q=I_I-I_{OUT}$, $V_{INH}=0V$			10	μA	
Quiescent Current	I_q	$I_q=I_I-I_{OUT}$	$I_{OUT}=1.0mA$		130	220	μA
			$I_{OUT}=250mA$		10	15	mA
			$I_{OUT}=400mA$		25	35	mA
Dropout Voltage	V_{DR}	$V_{IN}=4.5V$, $I_{OUT}=250mA$, $V_{DR}=V_{IN}-V_{OUT}$			2.1	V	
Load Regulation	ΔV_{OUT}	$I_{OUT}=5.0mA\sim 400mA$		10	35	mV	
Line Regulation	ΔV_{OUT}	$\Delta V_{IN}=12V\sim 32V$, $I_{OUT}=5.0mA$		2.5	25	mV	
Power Supply Ripple Rejection	PSRR	$f_r=100Hz$, $V_r=0.5V_{RMS}$		60		dB	
Temperature coefficient of V_{OUT}	$\Delta V_{OUT}/\Delta T$			0.5		mV/K	
INHIBIT							
Inhibit Voltage, Output High	V_{INH}	$V_{OUT}\geq V_{OUT(MIN)}$		2.8	3.5	V	
Inhibit Voltage, Output Low (Off)	V_{INH}	$V_{OUT}\leq 0.1V$	0.5	1.7		V	
Input Current	I_{INH}	$V_{INH}=5.0V$	5.0	10	20	μA	
THERMAL SHUTDOWN							
Thermal Shutdown Temperature (Note 2)	T_{SD}	$I_{OUT}=5.0mA$	150		210	$^{\circ}C$	

■ ELECTRICAL CHARACTERISTICS(Cont.)

For UCV676/A-3.3

PARAMETER	SYMBOL	TEST CONDITIONS	UCV676			UCV676A			UNIT	
			MIN	TYP	MAX	MIN	TYP	MAX		
OUTPUT										
Output Voltage	V_{OUT}	5.0mA< I_{OUT} <400mA, 4.5V< V_{IN} <28V	3.168	3.3	3.432	3.234	3.3	3.366	V	
		5.0mA< I_{OUT} <200mA, 4.5V< V_{IN} <40V	3.168	3.3	3.432	3.234	3.3	3.366	V	
Output Current Limitation	I_{OUT}	$V_{OUT}=90\% V_{OUT(TYP)}$	400	700	1100	400	700	1100	mA	
Quiescent Current (Sleep Mode)	I_q	$I_q=I_I-I_{OUT}, V_{INH}=0V$			10			10	μA	
Quiescent Current	I_q	$I_q=I_I - I_{OUT}$	$I_{OUT}=1.0mA$		130	220		130	200	μA
			$I_{OUT}=250mA$		10	15		10	15	mA
			$I_{OUT}=400mA$		25	35		25	35	mA
Dropout Voltage	V_{DR}	$V_{IN}=4.5V, I_{OUT}=250mA,$ $V_{DR}=V_{IN}-V_{OUT}$			1332		250	500	mV	
Load Regulation	ΔV_{OUT}	$I_{OUT}= 5.0mA\sim 400mA$		10	35		3.0	20	mV	
Line Regulation	ΔV_{OUT}	$\Delta V_{IN}=12V\sim 32V, I_{OUT}=5.0mA$		2.5	25		4.0	25	mV	
Power Supply Ripple Rejection	PSRR	$f_r=100Hz, V_r= 0.5V_{RMS}$		60			70		dB	
Temperature coefficient of V_{OUT}	$\Delta V_{OUT}/\Delta T$			0.5			0.5		mV/K	
INHIBIT										
Inhibit Voltage, Output High	V_{INH}	$V_{OUT}\geq V_{OUT(MIN)}$		2.8	3.5		2.3	2.8	V	
Inhibit Voltage, Output Low (Off)	V_{INH}	$V_{OUT}\leq 0.1V$	0.5	1.7		1.8	2.2		V	
Input Current	I_{INH}	$V_{INH}=5.0V$	5.0	10	20	5.0	10	20	μA	
THERMAL SHUTDOWN										
Thermal Shutdown Temperature (Note 2)	T_{SD}	$I_{OUT}=5.0mA$	150		210	150		210	$^{\circ}C$	

■ ELECTRICAL CHARACTERISTICS(Cont.)

For UCV676/A-5.0

PARAMETER	SYMBOL	TEST CONDITIONS	UCV676			UCV676A			UNIT	
			MIN	TYP	MAX	MIN	TYP	MAX		
OUTPUT										
Output Voltage	V_{OUT}	5.0mA< I_{OUT} <400mA, 6.0V< V_{IN} <28V	4.8	5.0	5.2	4.9	5.0	5.1	V	
		5.0mA< I_{OUT} <200mA, 6.0V< V_{IN} <40V	4.8	5.0	5.2	4.9	5.0	5.1	V	
Output Current Limitation	I_{OUT}	$V_{OUT}=90\% V_{OUT(TYP)}$	400	700	1100	400	700	1100	mA	
Quiescent Current (Sleep Mode)	I_q	$I_q=I_I-I_{OUT}, V_{INH}=0V$			10			10	μA	
Quiescent Current	I_q	$I_q=I_I - I_{OUT}$	$I_{OUT}=1.0mA$		130	220		130	200	μA
			$I_{OUT}=250mA$		10	15		10	15	mA
			$I_{OUT}=400mA$		25	35		25	35	mA
Dropout Voltage (Note 1)	V_{DR}	$V_{IN}=5.0V, I_{OUT}=250mA,$ $V_{DR}=V_{IN}-V_{OUT}$		250	500		250	500	mV	
Load Regulation	ΔV_{OUT}	$I_{OUT}= 5.0mA\sim 400mA$		10	35		3.0	20	mV	
Line Regulation	ΔV_{OUT}	$\Delta V_{IN}=12V\sim 32V, I_{OUT}=5.0mA$		2.5	25		2.5	25	mV	
Power Supply Ripple Rejection	PSRR	$f_r=100Hz, V_r= 0.5V_{RMS}$		60			70		dB	
Temperature coefficient of V_{OUT}	$\Delta V_{OUT}/\Delta T$			0.5			0.5		mV/K	
INHIBIT										
Inhibit Voltage, Output High	V_{INH}	$V_{OUT}\geq V_{OUT(MIN)}$		2.8	3.5		2.3	2.8	V	
Inhibit Voltage, Output Low (Off)	V_{INH}	$V_{OUT}\leq 0.1V$	0.5	1.7		1.8	2.2		V	
Input Current	I_{INH}	$V_{INH}=5.0V$	5.0	10	20	5.0	10	20	μA	
THERMAL SHUTDOWN										
Thermal Shutdown Temperature (Note 2)	T_{SD}	$I_{OUT}=5.0mA$	150		210	150		210	$^{\circ}C$	

■ ELECTRICAL CHARACTERISTICS(Cont.)

For UCV676/A-ADJ

PARAMETER	SYMBOL	TEST CONDITIONS	UCV676			UCV676A			UNIT	
			MIN	TYP	MAX	MIN	TYP	MAX		
OUTPUT										
Output Voltage, Adjustable Version	$A_{V_{OUT}}$	$5.0\text{mA} < I_{OUT} < 400\text{mA}$, $V_{OUT} + 1 < V_{IN} < 40\text{V}$, $V_{IN} > 4.5\text{V}$	-4%		+4%	-2%		+2%	V	
Output Current Limitation	I_{OUT}	$V_{OUT} = 90\% V_{OUT(TYP)}$ ($V_{OUT(TYP)} = 2.5\text{V}$)	400	700	1100	400	700	1100	mA	
Quiescent Current (Sleep Mode)	I_q	$I_q = I_I - I_{OUT}$, $V_{INH} = 0\text{V}$			10			10	μA	
Quiescent Current	I_q	$I_q = I_I - I_{OUT}$		$I_{OUT} = 1.0\text{mA}$	130	220		130	200	μA
				$I_{OUT} = 250\text{mA}$	10	15		10	15	mA
				$I_{OUT} = 400\text{mA}$	25	35		25	35	mA
Dropout Voltage	V_{DR}	$V_{IN} > 4.5\text{V}$, $I_{OUT} = 250\text{mA}$, $V_{DR} = V_{IN} - V_{OUT}$		250	500		250	500	mV	
Load Regulation	ΔV_{OUT}	$I_{OUT} = 5.0\text{mA} \sim 400\text{mA}$		10	35		3.0	20	mV	
Line Regulation	ΔV_{OUT}	$\Delta V_{IN} = 12\text{V} \sim 32\text{V}$, $I_{OUT} = 5.0\text{mA}$		2.5	25		4.0	25	mV	
Power Supply Ripple Rejection	PSRR	$f_r = 100\text{Hz}$, $V_r = 0.5V_{RMS}$		60			70		dB	
Temperature coefficient of V_{OUT}	$\Delta V_{OUT}/\Delta T$			0.5			0.5		mV/K	
INHIBIT										
Inhibit Voltage, Output High	V_{INH}	$V_{OUT} \geq V_{OUT(MIN)}$		2.8	3.5		2.3	2.8	V	
Inhibit Voltage, Output Low (Off)	V_{INH}	$V_{OUT} \leq 0.1\text{V}$	0.5	1.7		1.8	2.2		V	
Input Current	I_{INH}	$V_{INH} = 5.0\text{V}$	5.0	10	20	5.0	10	20	μA	
THERMAL SHUTDOWN										
Thermal Shutdown Temperature (Note 2)	T_{SD}	$I_{OUT} = 5.0\text{mA}$	150		210	150		210	$^{\circ}\text{C}$	

Notes: 1. Measured when the output voltage V_{OUT} has dropped 100mV from the nominal valued obtained at $V = 13.5\text{V}$.

2. Guaranteed by design, not tested in production.

TYPICAL APPLICATION CIRCUIT

Fixed Voltage Version

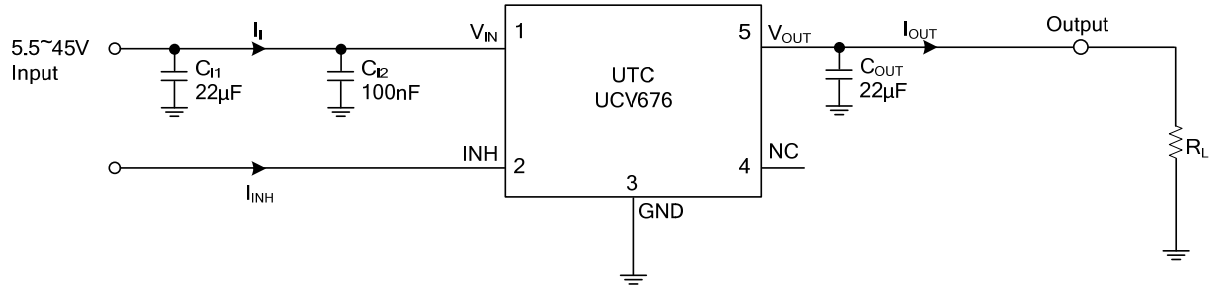

Adjustable Voltage Version

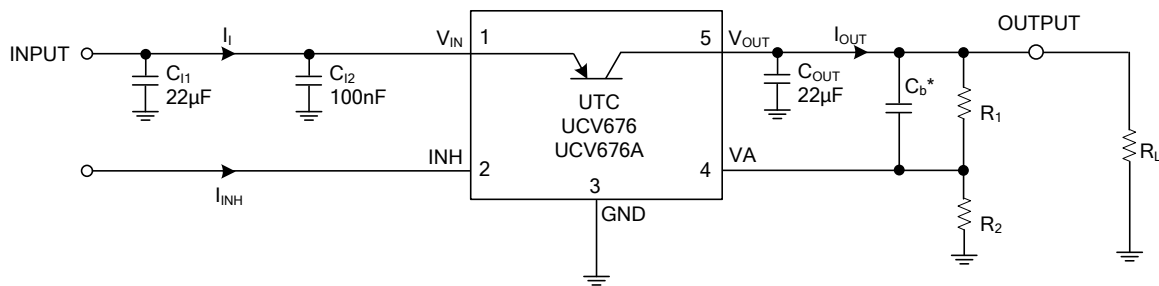

$$V_{OUT} = [(R1 + R2) \times V_{REF}] / R2$$

* Required if usage of low ESR output capacitor CQ is demand.

TYPICAL CHARACTERISTICS

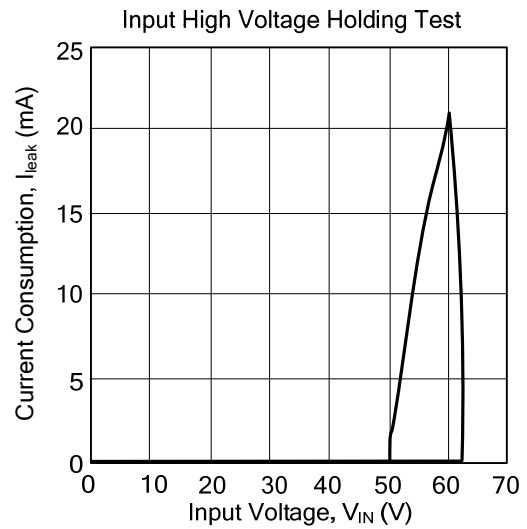
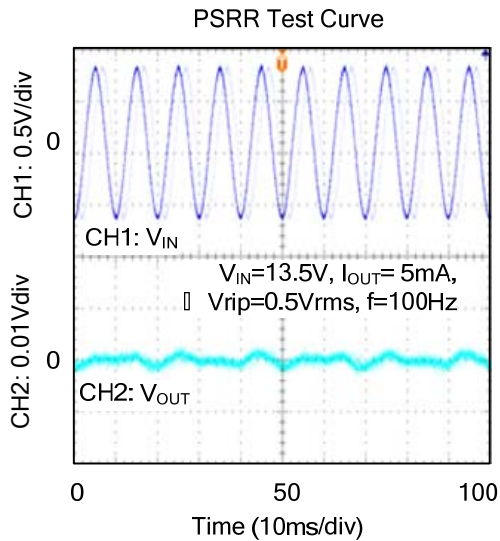

UTC assumes no responsibility for equipment failures that result from using products at values that exceed, even momentarily, rated values (such as maximum ratings, operating condition ranges, or other parameters) listed in products specifications of any and all UTC products described or contained herein. UTC products are not designed for use in life support appliances, devices or systems where malfunction of these products can be reasonably expected to result in personal injury. Reproduction in whole or in part is prohibited without the prior written consent of the copyright owner. The information presented in this document does not form part of any quotation or contract, is believed to be accurate and reliable and may be changed without notice.