



## LM5954

Preliminary

LINEAR INTEGRATED CIRCUIT

### HIGH INPUT VOLTAGE, LOW QUIESCENT CURRENT, 300mA LDO REGULATOR

#### DESCRIPTION

The **UTC LM5954** is a low ground current linear regulator which operates with input voltage from 6.5V ~ 25V and delivers output current up to 300mA. Typical dropout voltage is only 450mV at 300mA loading.

The **UTC LM5954** has many protection functions including over temperature and current limit which prevent the device from thermal over-load and current over-load.

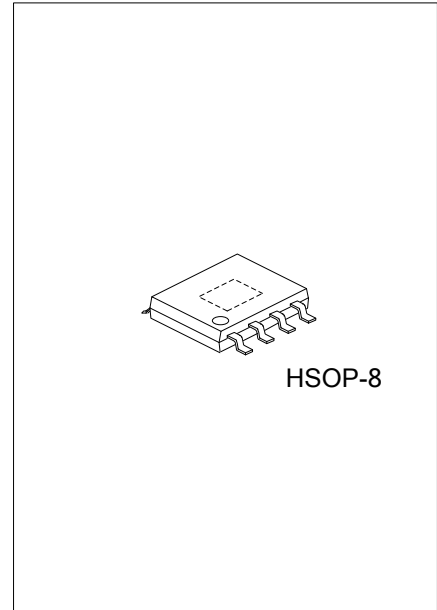

#### FEATURES

- \* Wide Operating Voltage : 6.5V~25V
- \* Ultra Low Ground Current :120μA
- \* High Output Accuracy : ±2% over temperature
- \* Excellent Load/Line Transient
- \* Low Dropout Voltage : 450mv @ 300mA
- \* Built-in Current Limit Protection
- \* Built-in Over Temperature Protection
- \* Zero Shutdown Current

#### ORDERING INFORMATION

Ordering Number		Package	Packing
Lead Free	Halogen Free		
LM5954L-xx-SH2-R	LM5954G-xx-SH2-R	HSOP-8	Tape Reel
LM5954L-xx-SH2-T	LM5954G-xx-SH2-T	HSOP-8	Tube

Note: xx: Output Voltage, refer to Marking Information.

<p>LM5954L-xx-SH2-R</p>	<p>(1) Packing Type (2) Package Type (3) Output Voltage Code (4) Lead Free</p>	<p>(1) R: Tape Reel, T: Tube (2) SH2: HSOP-8 (3) xx: Refer to Marking Information (4) G: Halogen Free, L: Lead Free</p>
-------------------------	--	---

■ MARKING INFORMATION

PACKAGE	VOLTAGE CODE	MARKING
HSOP-8	AD :ADJ	

■ PIN CONFIGURATION

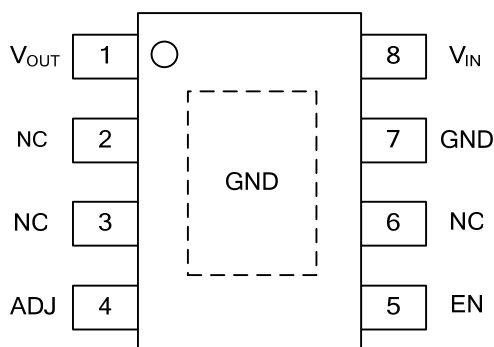

■ PIN DESCRIPTION

PIN NO.	PIN NAME	DESCRIPTION
1	$V_{OUT}$	Output pin
2, 3, 6	NC	No Connection
4	ADJ	ADJ: output feedback pin
5	EN	ON/OFF pin, low=output ON; high=output OFF
7	GND	Ground
8	$V_{IN}$	Input pin

■ BLOCK DIAGRAM

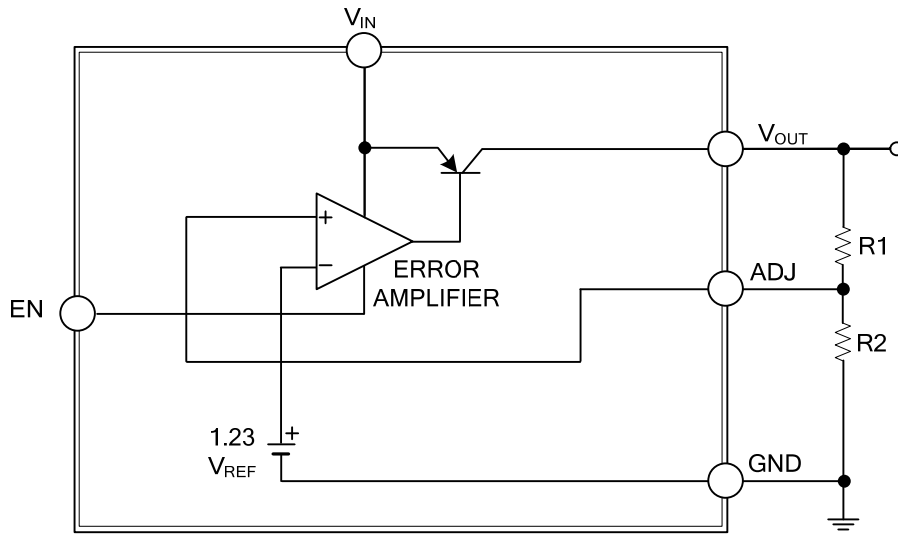

### ■ ABSOLUTE MAXIMUM RATING

PARAMETER	SYMBOL	RATINGS	UNIT
Supply Voltage	$V_{CC}$	-0.3~+27	V
Feedback Voltage	$V_{FB}$	-1.5~+27	V
Shutdown Voltage	$V_{SHDN}$	-0.3~+27	V
Power Dissipation	$P_D$	Internally Limited	W
Junction Temperature	$T_J$	+125	°C
Storage Temperature	$T_{STG}$	-65~+150	°C

Note: Absolute maximum ratings are those values beyond which the device could be permanently damaged. Absolute maximum ratings are stress ratings only and functional device operation is not implied.

### ■ THERMAL DATA

PARAMETER	SYMBOL	RATINGS	UNIT
Junction to Ambient	$\theta_{JA}$	50	°C/W
Junction to Case	$\theta_{JC}$	20	°C/W

### ■ ELECTRICAL CHARACTERISTICS

(Unless otherwise specified, these specifications apply over  $V_{IN}=V_{OUT}+2.5V$ ,  $C_{IN}=1\mu F$ ,  $C_{OUT}=2.2\mu F$ ,  $T_A=-40^\circ C \sim 85^\circ C$ . Typical values refer to  $T_A=25^\circ C$ .)

PARAMETER	SYMBOL	TEST CONDITIONS	MIN	TYP	MAX	UNIT
Input Voltage	$V_{IN}$		6.5		25	V
Output Voltage Accuracy	$V_{OUT}$		-2		2	%
Output Voltage Range			3		20	V
Quiescent Current	$I_Q$	$I_{OUT}=0.1mA$	75	120	140	$\mu A$
		$I_{OUT}=300mA$	8	12	22	mA
Load Current Range	$I_{OUT}$		0		300	mA
Reference Voltage	$V_{REF}$		-2%	1.235	+2%	V
Line Regulation	$\Delta V_{OUT}$	$V_{OUT}+2.5V < V_{IN} < 25V$ , $I_{OUT}=1mA$		0.1	0.2	%
Load Regulation	$\Delta V_{OUT}$	$0.1mA < I_{OUT} < 300mA$		0.2	0.5	%
Dropout Voltage	$V_D$	$I_{OUT}=0.1mA$	50	80	150	mV
		$I_{OUT}=300mA$	380	450	600	
<b>PROTECTION</b>						
Over Temperature Shutdown	OTS			150		°C
Circuit Current Limit	$I_{LIMIT}$	$V_{IN}=V_{OUT}+2.5V$	350	400	500	mA
Short Current	$I_{SHORT}$	$V_{OUT}=0V$		50		mA
<b>SHUTDOWN</b>						
Input High Voltage	$V_{EN}$		2			V
Input Low Voltage					0.7	
EN pin Input Bias Current	$I_{EN}$	$V_{EN}=25V$		450	600	$\mu A$
Shutdown Supply Current	$I_{QSHDN}$	EN=High, $V_{IN}=19V$		0.1	1	mA

## ■ TYPICAL APPLICATION CIRCUIT

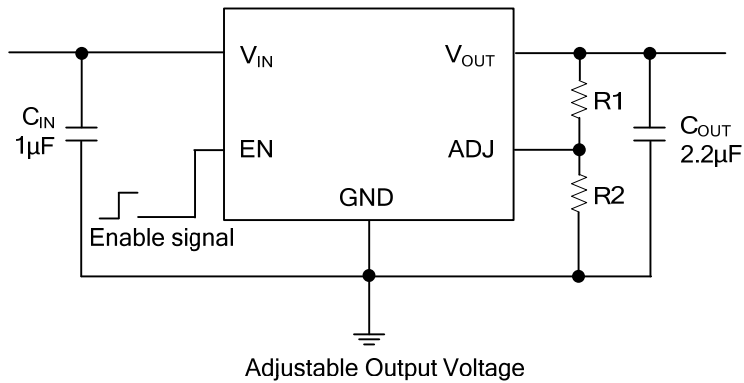

UTC assumes no responsibility for equipment failures that result from using products at values that exceed, even momentarily, rated values (such as maximum ratings, operating condition ranges, or other parameters) listed in products specifications of any and all UTC products described or contained herein. UTC products are not designed for use in life support appliances, devices or systems where malfunction of these products can be reasonably expected to result in personal injury. Reproduction in whole or in part is prohibited without the prior written consent of the copyright owner. The information presented in this document does not form part of any quotation or contract, is believed to be accurate and reliable and may be changed without notice.