

### Description

The BL8003L is an integrated high-speed half bridge power MOSFET driver. Our proprietary DBiCMOS technologies provide stable operation under high dv/dt noise circumstances. The output drivers feature a high pulse current buffer stage designed for minimum driver cross-conduction. The floating channel can be used to drive an N-channel power MOSFET on the high side. The logic input is compatible with standard CMOS or LSTTL, down to 3.3V logic. Cross conduction prevention logic and dead-times are built in to simplify the applications.

### Features

- DBiCMOS technologies, low power dissipation and high output current
- Internal 5V LDO, CMOS and LSTTL logic (5V and 3.3V) compatible
- Cross conduction prevention logic
- Gate drive supply range from 10V to 15V
- Internal set deadtime
- High side output of phase with HIN input
- Low side output of phase with LIN input.

### Ordering Information

BL8003L 1 2 3

Code	Description
<span style="border: 1px solid black; padding: 0 2px;">1</span>	Temperature&Rohs: C: -40~85°C ,Pb Free Rohs Std.
<span style="border: 1px solid black; padding: 0 2px;">2</span>	Package type: D8: SOIC-8
<span style="border: 1px solid black; padding: 0 2px;">3</span>	Packing type: TR: Tape&Reel (Standard)

### Marking Information

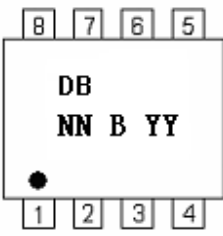
Product Classification		BL8003LCD8TR
Marking		
DM NN B YY	DB: Product Code	
	NN: LOT NO.	
	B: FAB Code	
	YY: Date Code	

### Lead Assignments

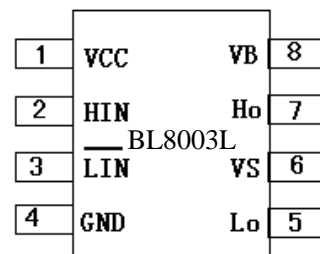

## Pin Descriptions

Symbol	Description
HIN	Logic input for high side gate driver output (H <sub>O</sub> ), in phase
$\overline{\text{LIN}}$	Logic input for low side gate driver output (L <sub>O</sub> ), out of phase
V <sub>B</sub>	High side floating supply
H <sub>O</sub>	High side gate drive output
V <sub>S</sub>	High side floating supply return
V <sub>CC</sub>	Low side and logic fixed supply
L <sub>O</sub>	Low side gate drive output
GND	Low side return

## Functional Block Diagram

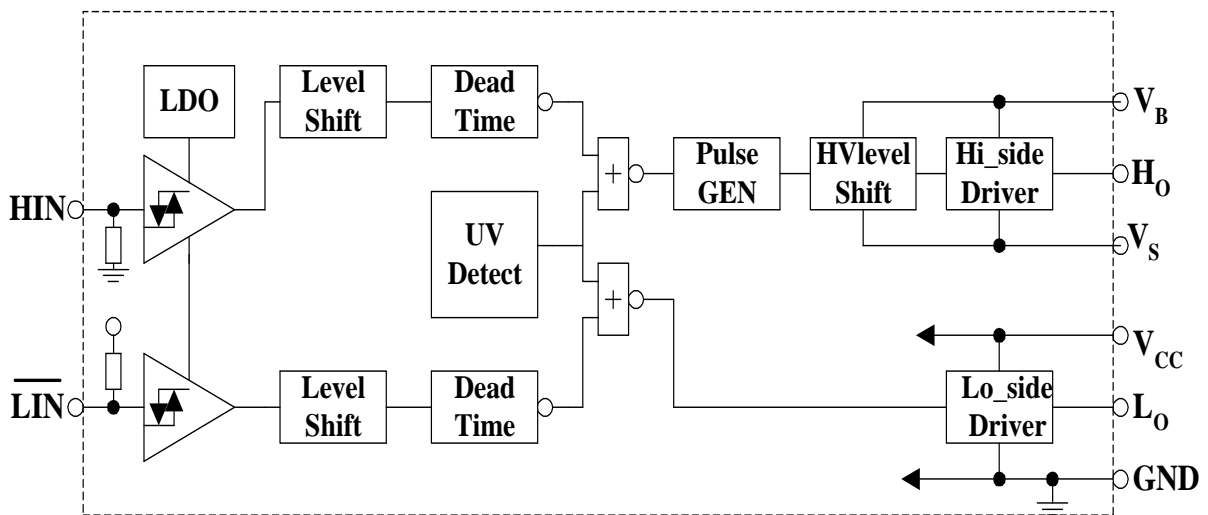

## Typical Connection

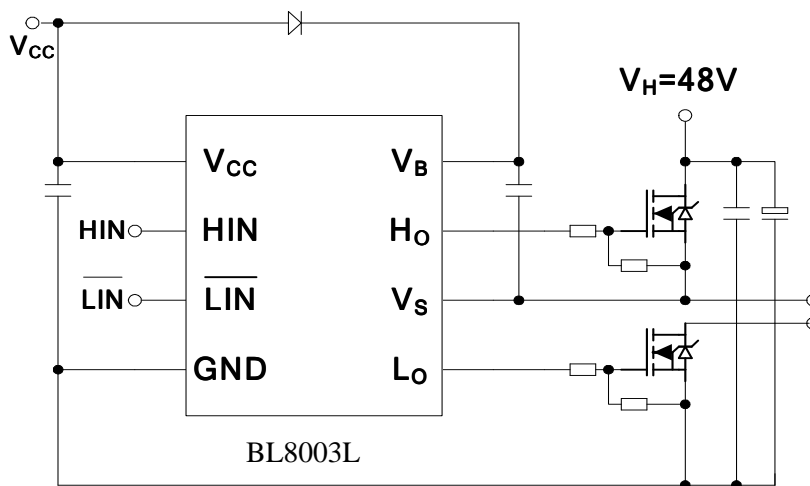

## Absolute Maximum Ratings

Symbol	Definition	Min.	Max.	Unit
V <sub>CC</sub>	Low side and logic fixed supply voltage	-0.3	16	V
V <sub>B</sub>	High side floating absolute voltage	-0.3	100	V
V <sub>S</sub>	High side floating supply offset voltage	V <sub>B</sub> -16	V <sub>B</sub> +0.3	V
P <sub>D</sub>	Package power dissipation @ T <sub>A</sub> ≤+25°C		0.625	W
R <sub>thJA</sub>	Thermal resistance, junction to ambient		200	°C/W

## Recommended Operating Conditions

Symbol	Min.	Typ.	Max.	Units
V <sub>B</sub>	V <sub>S</sub> +10	V <sub>S</sub> +12	V <sub>S</sub> +15	V
V <sub>S</sub>	Note1		80	V
V <sub>HO</sub>	V <sub>S</sub>		V <sub>B</sub>	V
V <sub>CC</sub>	10	12	15	V
V <sub>H</sub>	V <sub>CC</sub>	48	80	V
T <sub>A</sub>	-40		125	°C

Note 1: Logic operational for V<sub>S</sub> of -5 to 80V.

## Electrical Characteristics

V<sub>BIAS</sub> (V<sub>CC</sub>, V<sub>BS</sub>)=12V, unless specified otherwise.

Symbol	Definition	Min	Typ	Max	Unit	Test Conditions
V <sub>IH</sub>	Logic "1" (HIN) & "0" (LIN) input voltage	3			V	V <sub>CC</sub> =10 to 15V
V <sub>IL</sub>	Logic "0" (HIN) & "1" (LIN) input voltage			0.8	V	V <sub>CC</sub> =10 to 15V
V <sub>OH</sub>	High level output voltage, V <sub>BIAS</sub> -V <sub>O</sub>			100	mV	I <sub>O</sub> =0A
V <sub>OL</sub>	Low level output Voltage, V <sub>O</sub>			100	mV	I <sub>O</sub> =0A
I <sub>QCC</sub>	Quiescent V <sub>CC</sub> supply current	50	100	150	uA	V <sub>CC</sub> =15V
V <sub>CC_uv+</sub>	V <sub>CC</sub> supply undervoltage positive going threshold		9.1		V	
V <sub>CC_uv-</sub>	V <sub>CC</sub> supply undervoltage negative going threshold		8.3		V	
I <sub>QBS</sub>	Quiescent V <sub>BS</sub> supply current	0	25	55	uA	
I <sub>LK</sub>	V <sub>S</sub> to GND leakage current	0	10	50	nA	V <sub>S</sub> =48V
I <sub>O+</sub>	Peak source output current	130	210		mA	C <sub>L</sub> =10nF
I <sub>O-</sub>	Peak sink output current	300	430		mA	
DT	Deadtime	500	600	700	nS	

## Input/output True table

<b>Hin</b>	<b><math>\overline{\text{Lin}}</math></b>	<b>Ho</b>	<b>Lo</b>
0	0	0	1
0	1	0	0
1	0	0	0
1	1	1	0

## Input/output Timing Diagram

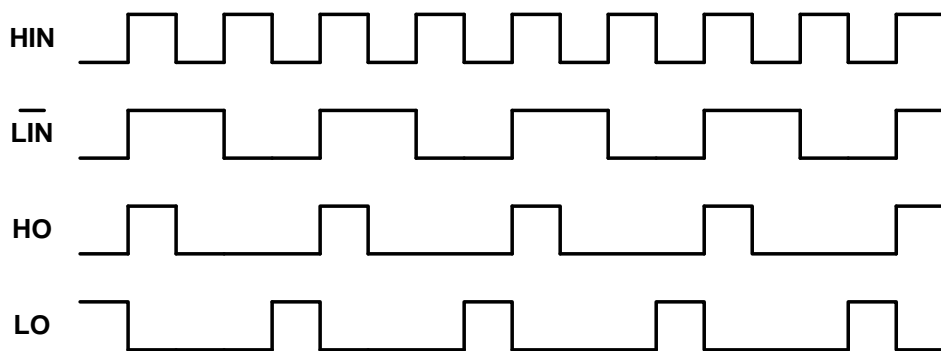

Figure 1: Input/output Timing Diagram

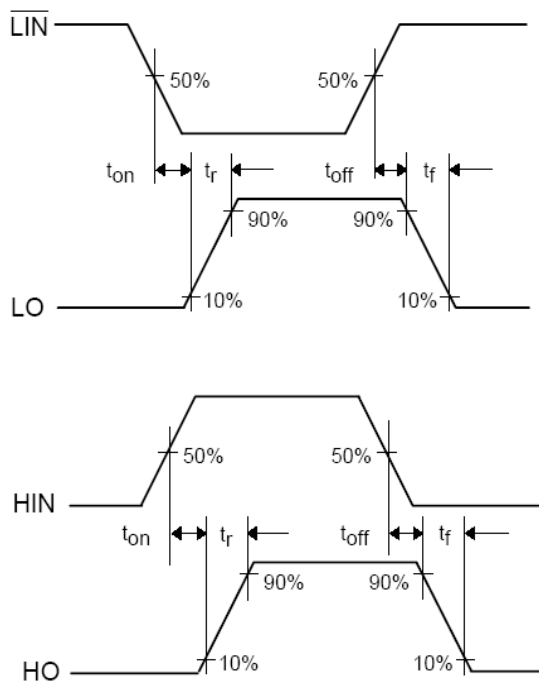

Figure 2: Switch Time Definition

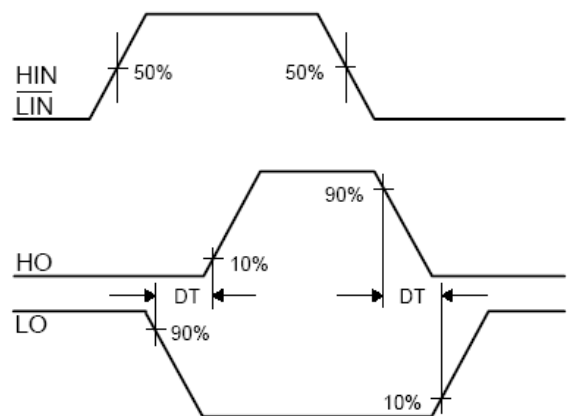
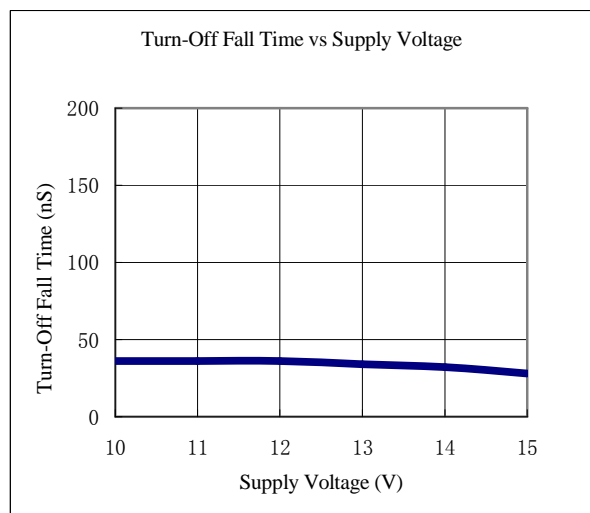
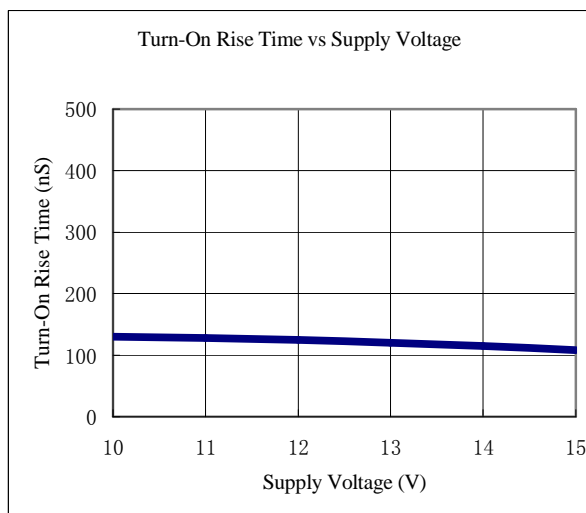
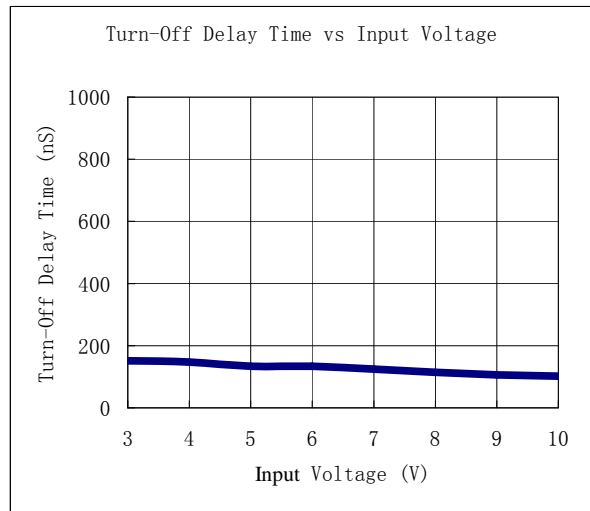
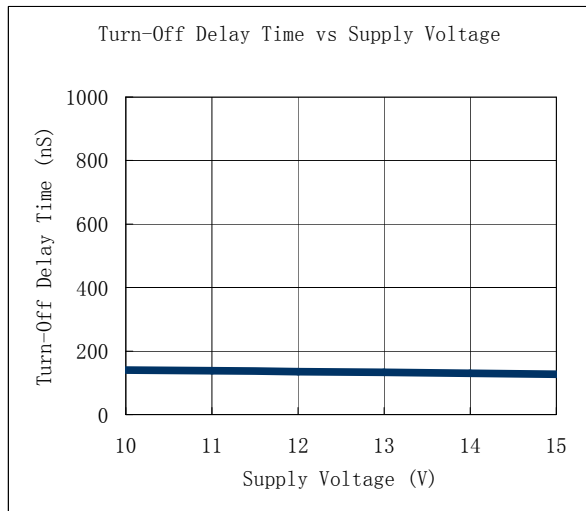
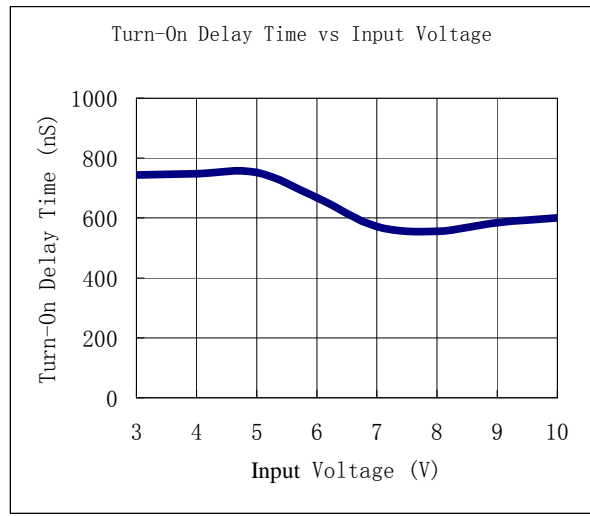
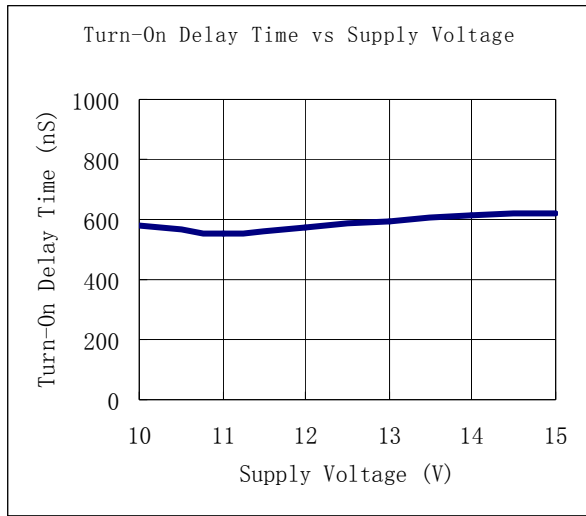
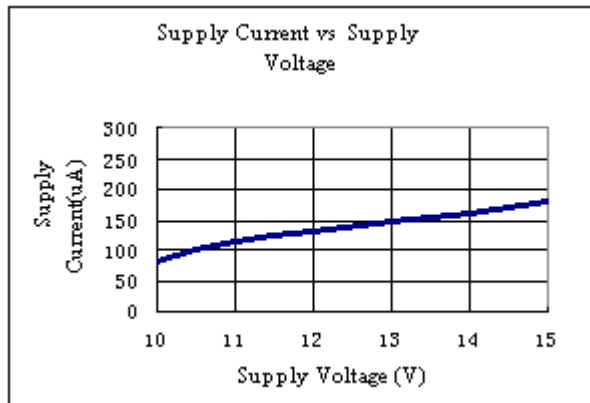
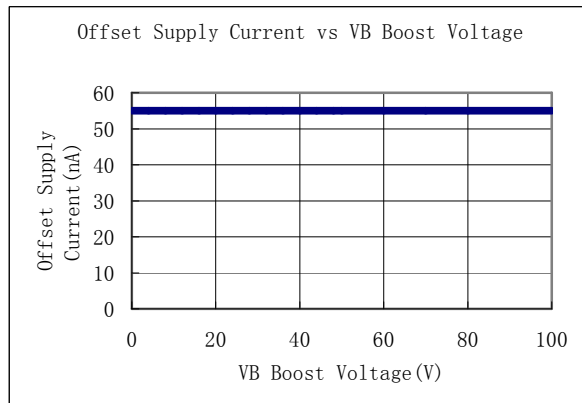
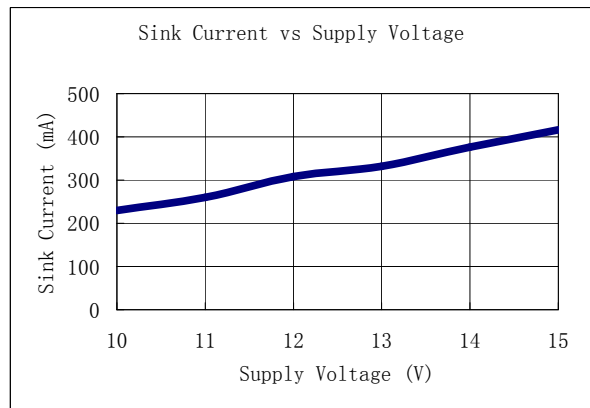
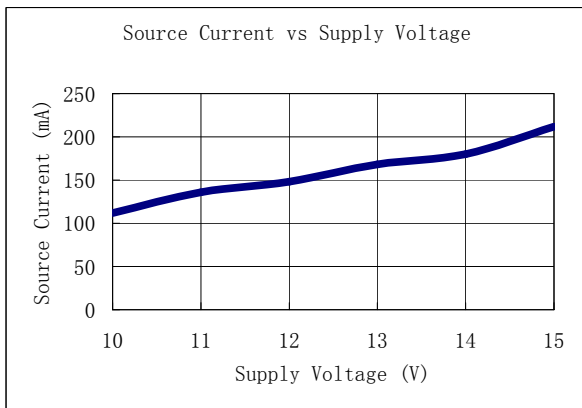
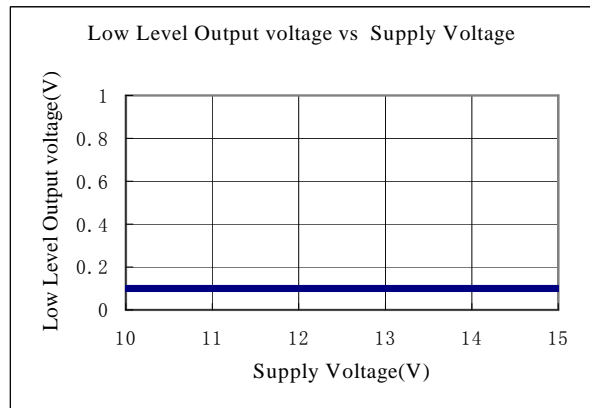
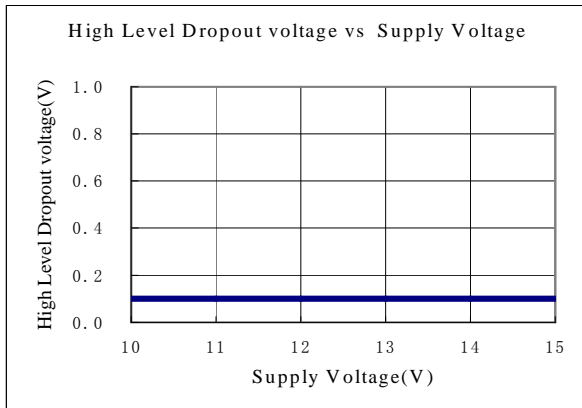
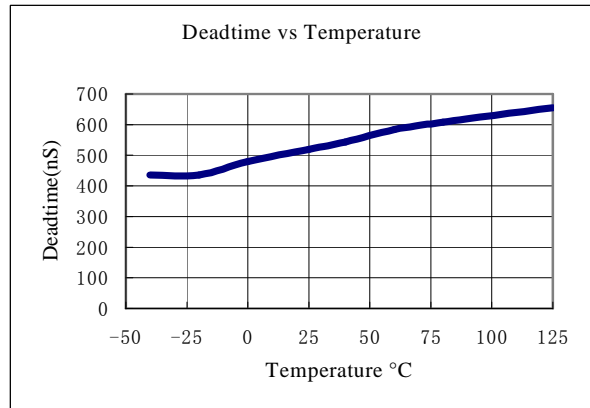
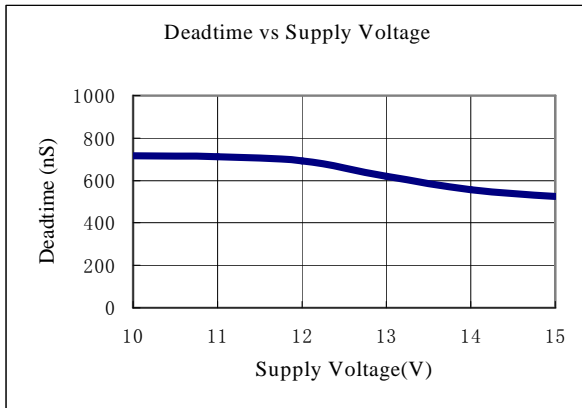

Figure 3: Dead Time Definition

## Typical Characteristics



## Typical Characteristics (Continued)



## Packaging Information

Package	SOIC-8	Devices per reel	2500Pcs	Unit	mm
---------	--------	------------------	---------	------	----

Package specification:

SYMBOL	MILLIMETER		
	MIN	NOM	MAX
A	—	—	1.77
A1	0.08	0.18	0.28
A2	1.20	1.40	1.60
A3	0.55	0.65	0.75
b	0.39	—	0.48
b1	0.38	0.41	0.43
c	0.21	—	0.26
c1	0.19	0.20	0.21
D	4.70	4.90	5.10
E	5.80	6.00	6.20
E1	3.70	3.90	4.10
e	1.27BSC		
L	0.50	0.65	0.80
L1	1.05BSC		
$\theta$	0	—	8°

SECTION B-B