

Description

The BL6316 is a high efficiency, 3W/channel stereo class-D audio power amplifier. A Low noise, filterless architecture eliminates the out filter, it required few external components for operation to save the board space and cost.

Operating from a single 5V supply, the BL6316 is capable of driving 3.2W/CH into 3 Ω at 5V.

The BL6316 features shutdown and mute controls functions. High PSRR and differential architecture provide increased immunity to noise and RF rectification.

The BL6316 is available in SOP-16 PB-Free package.

Features

- ◆ Low EMI Emission
- ◆ Filterless Class-D Architecture
- ◆ Output Power
 - 3.2W/ch ($V_{DD}=5.0V$, $R_L=3\Omega$, THD+N=10%)
 - 1.7W/ch ($V_{DD}=5.0V$, $R_L=8\Omega$, THD+N=10%)
- ◆ Supply Voltage:2.2V to 5.0V
- ◆ Low THD+N and Low Noise
- ◆ High Efficiency up to 85%
- ◆ Short Circuit auto Recovery and Thermal Protection
- ◆ Few External Components to Save the Space and Cost

Applications

- ◆ Portable DVD Players
- ◆ Notebook PC
- ◆ USB Speakers, Portable Speaker
- ◆ LCD TV/LCD Monitor

Typical Application

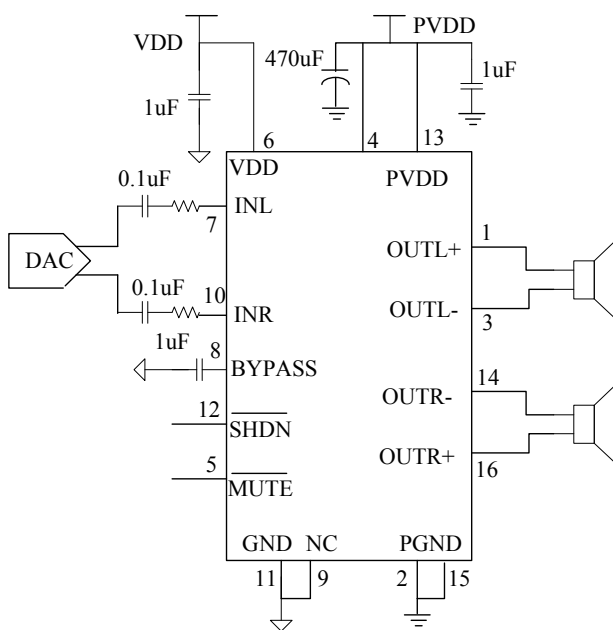

Pin Configuration

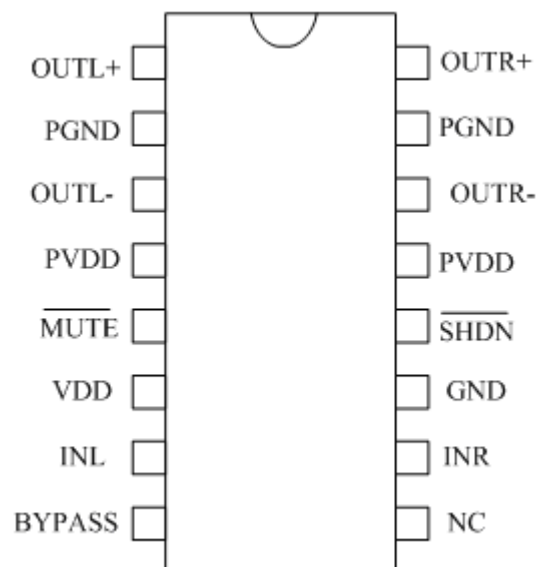

Block Diagram

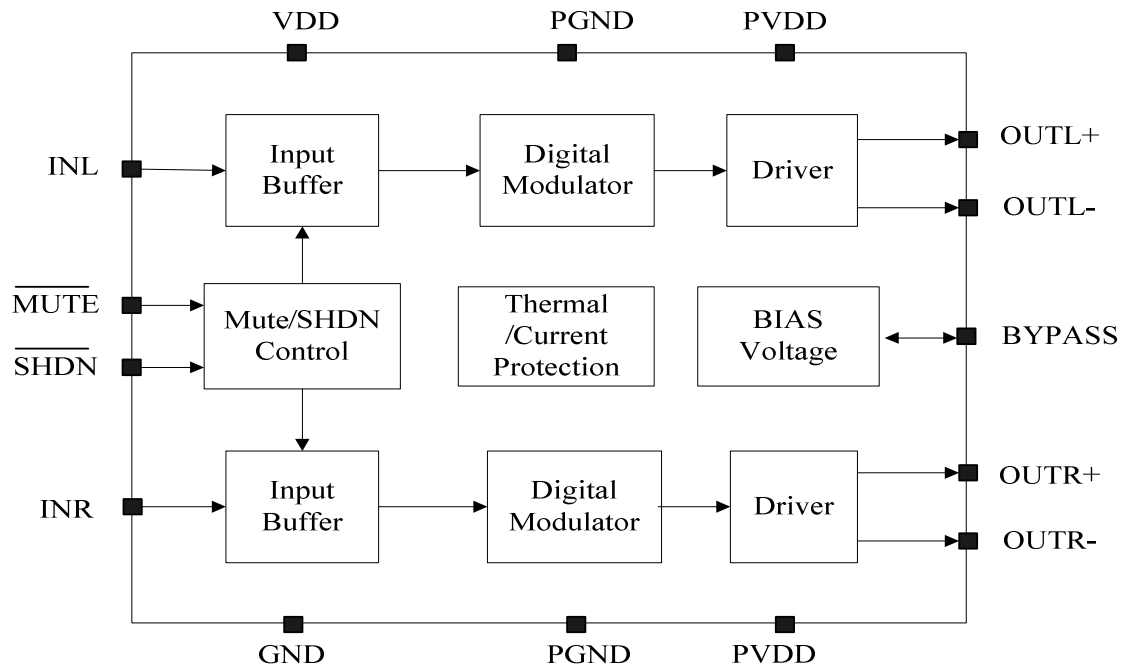

Pin Descriptions

Name	Pin No.	I/O	Pin Description
1	OUTL+	O	Left Channel Positive Audio Output
2,15	PGND		Power Ground
3	OUTL-	O	Left Channel Negative Audio Output
4,13	PVDD		Supply Voltage Terminal for Power Stage
5	$\overline{\text{MUTE}}$	I	Mute Control Input Pin (active low)
6	VDD		Analog Supply Voltage Terminal
7	INL	I	Left Channel Input Pin
8	BYPASS	I	Tap to voltage divider for internal midsupply bias generator used for analog reference
9	NC		No Connection
10	INR	I	Right Channel Input Pin
11	GND		Analog Power Supply Ground
12	$\overline{\text{SHDN}}$	I	Shutdown Control Input Pin (active low)
14	OUTR-	O	Right Channel Negative Audio Output
16	OUTR+	O	Right Channel Positive Audio Output

Ordering Information

Order Number	Package Type	Marking	Packing
BL6316	SOP-16	BL6316 XXXXX	Reel Tape
			Tube

Absolute Maximum Ratings (Over operating free-air temperature, unless otherwise noted)

V _{SS}	Supply voltage	-0.3V to 5.5V
V _I	Input voltage	-0.3V to V _{DD} +0.3V
T _A	Operation free-air temperate range	-40°C to 85°C
T _J	Operation free-air junction temperature	-40°C to 125°C
T _{STG}	Storage temperature range	-65°C to 150°C
T _{SLD}	Soldering temperature	300°C, 5sec

Recommended Operating Conditions

			MIN	MAX	UNIT
V _{SS}	Supply Voltage	AVDD, PVDD	2.2	5.0	V
V _{IH}	Enable Input High Voltage	V _{DD} =5.0V	1.3		V
V _{IL}	Enable Input Low Voltage	V _{DD} =5.0V		0.4	
V _{IH}	Mute Input High Voltage	V _{DD} =5.0V	1.3		V
V _{IL}	Mute Input Low Voltage	V _{DD} =5.0V		0.4	

Thermal Information

Parameter	Symbol	Package	MAX	UNIT
Thermal Resistance (Junction to Ambient)	θ _{JA}	SOP-16	110	°C/W
Thermal Resistance (Junction to Case)	θ _{JC}	SOP-16	23	°C/W

Electrical Characteristics ($V_{DD}=5V$, Gain=21dB, $R=8\Omega$, $T=25^{\circ}C$, unless otherwise noted.)

Symbol	Parameter	Test Conditions		MIN	TYP	MAX	UNIT
V_{IN}	Supply Power			2.2		5.0	V
P_O	Output Power	THD+N=10%,f=1KHZ, $R_L=4\Omega$	$V_{DD}=5.0V$		2.8		W
			$V_{DD}=3.6V$		1.3		
		THD+N=1%,f=1KHZ, $R_L=4\Omega$	$V_{DD}=5.0V$		2.1		W
			$V_{DD}=3.6V$		1		
		THD+N=10%,f=1KHZ, $R_L=8\Omega$	$V_{DD}=5.0V$		1.7		W
			$V_{DD}=3.6V$		0.8		
THD+N=1%,f=1KHZ, $R_L=8\Omega$	$V_{DD}=5.0V$		1.20		W		
	$V_{DD}=3.6V$		0.6				
THD+N	Total Harmonic Distortion Plus Noise	$V_{DD}=5.0V, P_O=0.5W, R_L=8\Omega$	f=1KHz		0.15		%
		$V_{DD}=3.6V, P_O=0.5W, R_L=8\Omega$			0.14		
		$V_{DD}=5.0V, P_O=1W, R_L=4\Omega$	f=1KHz		0.18		%
		$V_{DD}=3.6V, P_O=1W, R_L=4\Omega$			0.16		
G_V	Gain				25		dB
PSRR	Power Supply Ripple Rejection	$V_{DD}=5.0V$, Inputs ac-grounded with $C_{IN}=0.47\mu F$	f=1KHz		-55		dB
C_S	Crosstalk	$V_{DD}=5.0V, P_O=0.5W, R_L=8\Omega, G_V=25dB$	f=1KHz		-85		dB
SNR	Signal-to-Noise Ratio	$V_{DD}=5.0V, V_{rms}=1V, G_V=25dB$	f=1KHz		82		dB
V_n	Output Noise	$V_{DD}=5.0V$, Inputs floating with $C_{IN}=0.47\mu F$	A-weighting		87		μV
			No A-weighting		136		
Dyn	Dynamic range	$V_{DD}=5.0V, THD=1\%$	f=1KHz		90		dB
η	Efficiency	$R_L=8\Omega, THD=10\%$	f=1KHz		85		%
		$R_L=4\Omega, THD=10\%$			80		
I_Q	Quiescent Current	$V_{DD}=5.0V$	No Load		5		mA
		$V_{DD}=3.0V$			3.6		
I_{MUTE}	Muting Current	$V_{DD}=5.0V$	$V_{MUTE}=0.3V$		3.5		mA
I_{SD}	Shutdown Current	$V_{DD}=2.5V$ to $5.5V$	$V_{SD}=0.3V$			1	μA
V_{OS}	Output Offset Voltage	$V_{IN}=0V, V_{DD}=5V$			10		mV
OTP	Over Temperature Protection	No Load, Junction Temperature	$V_{DD}=5.0V$		135		$^{\circ}C$
OTH	Over Temperature Hysteresis				20		

Typical Operating Characteristics

(VDD =5V, Gain=21dB, $R_L = 8\Omega$, T =25°C, unless otherwise noted.)

THD+N vs Output Power

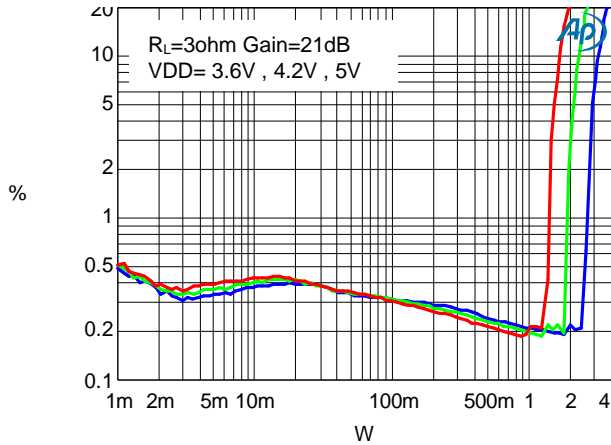

THD+N vs Output Power

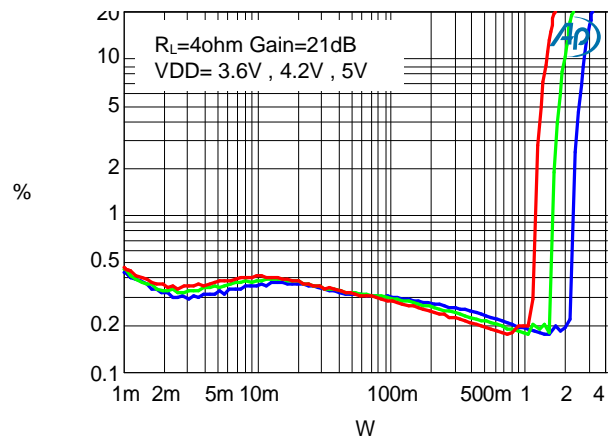

THD+N VS vs Output Power

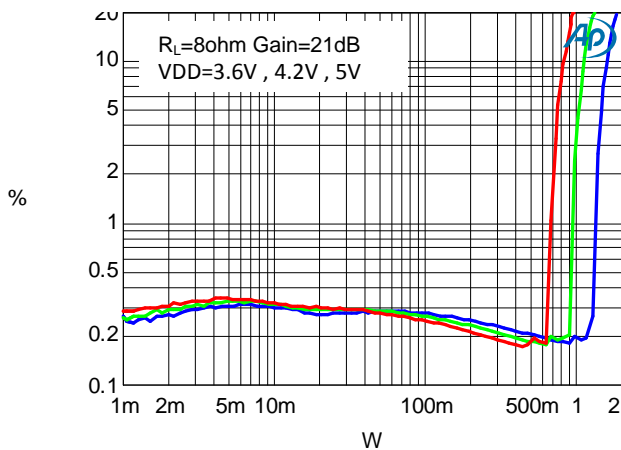

THD+N VS FREQUENCY

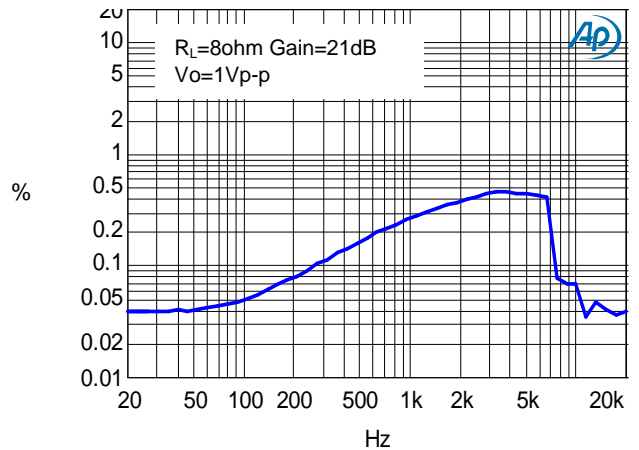

NOISE FLOOR FFT

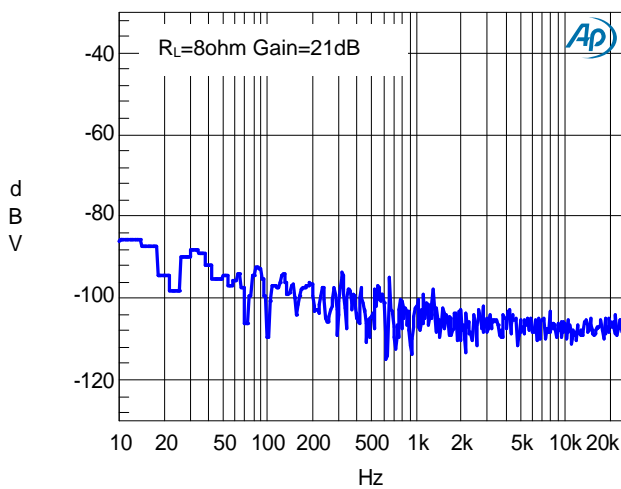

Frequency Response

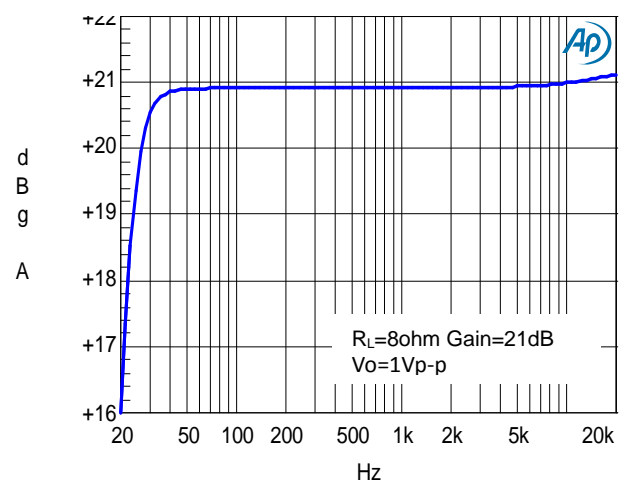

Application Information

Mute Operation

The $\overline{\text{MUTE}}$ pin is an input for controlling the output state of the BL6316. A logic high on this pin enables the outputs, a logic low on this pin disables the outputs. The terminal may be used as a quick disable/enable of the outputs when changing channels between different audio sources. The $\overline{\text{MUTE}}$ pin can be left floating due to the internal pull-up.

Shutdown operation

The BL6316 employs a shutdown mode of operation designed to reduce supply current to the absolute minimum level during periods of nonuse for power conservation. The $\overline{\text{SHDN}}$ input terminal should be held high during normal operation when the amplifier is in use. The $\overline{\text{SHDN}}$ pin can be left floating due to the internal pull-up.

Under Voltage Lock-out (UVLO)

The BL6316 incorporates circuitry designed to detect low supply voltage. When the supply voltage drops to 1.8V or below, the BL6316 outputs are disabled, and the device comes out of this state and starts to normal function when $V_{DD} \geq 2.0V$.

Short -Circuit Protection

The BL6316 has short circuit protection circuitry on the outputs to prevent damage to the device during output-to-output shorts and output-to-GND short occurs. When a short circuit is detected on the outputs, the part immediately disables the drive. This is an unlatched fault. Normal operation is restored when the fault is removed.

Thermal Protection

Thermal protection on the BL6316 prevents

damage to the device when the internal die temperature exceeds 135°C. There is a $\pm 20^\circ\text{C}$ tolerance on this trip point from device to device. Once the die temperature exceeds the thermal set point, the device enters into the shutdown state and the outputs are disabled. This is not a latched fault. The thermal fault is cleared once the temperature of the die is reduced by 30°C. The device begins normal operation at this point with no external system intervention.

Maximum Gain

The BL6316 has two internal amplifier stages. The first stage's gain is externally configurable, while the second stage's is internally fixed. The differential gain for the IC is

$$A = 20 \cdot \log [2 \cdot ((R_f / (R_i + R_e)))]$$

Where R_e is externally resistor, The BL6316 $R_f = 180k\Omega$, $R_i = 20k\Omega$, so the maximum closed-gain is 25dB (no externally resistor).

Decoupling Capacitor (C_s)

The BL6316 is a high-performance Class-D audio amplifier that requires adequate power supply decoupling to ensure the efficiency is high and total harmonic distortion (THD) is low. For higher frequency transients, spikes, or digital hash on the line a good low equivalent series resistance (ESR) ceramic capacitor, typically 1 μF , placed as close as possible to the device PVDD lead works best. Placing this decoupling capacitor close to the BL6316 is important for the efficiency of the Class-D amplifier, because any resistance or inductance in the trace between the device and the capacitor can cause a loss in efficiency. For filtering lower-frequency noise signals, a 4.7 μF or greater capacitor placed near the audio power amplifier would also help, but it is not required in most applications because of the high PSRR of this device.

Input Capacitors (C_i)

The input capacitors and input resistors form a high-pass filter with the corner frequency, f_c , determined in below equation

$$f_c = \frac{1}{2\pi R_i C_i}$$

The value of input capacitor is important to consider as it directly affects the bass (low frequency) performance of the circuit. Speaker in wireless phones cannot usually respond well to low frequencies, so the corner frequency can be set to block low frequencies in this application. Not using input capacitors can increase output offset. Below equation is used to solve for the input coupling capacitance.

$$C_i = \frac{1}{(2\pi R_i f_c)}$$

If the corner frequency is within the audio band, the capacitors should have tolerance of 10% or better, because any mismatch in capacitance causes an impedance mismatch at the corner frequency and below.

Analog Reference Bypass Capacitor (C_{BYP})

The Analog Reference Bypass Capacitor (C_{BYP}) is the most critical capacitor and serves several important functions. During start-up or recovery from shutdown mode, C determines the rate at which the amplifier starts up. The second function is to reduce noise caused by the power supply coupling into the output drive signal. This noise is

from the internal analog reference to the amplifier, which appears as degraded PSRR and THD+N.

A ceramic bypass capacitor (C_{BYP}) with values of $0.47\mu F$ to $1.0\mu F$ is recommended for the best THD and noise performance. Increasing the bypass capacitor reduces clicking and popping noise from power on/off and entering and leaving shutdown.

Filter Free Operation and Ferrite Bead Filters

A ferrite bead filter can often be used if the design is failing radiated emissions without an LC filter and the frequency sensitive circuit is greater than 1MHz. This filter functions well for circuits that just have to pass FCC and CE because FCC and CE only test radiated emissions greater than 30MHz. When choosing a ferrite bead, choose one with high impedance at high frequencies, and very low impedance at low frequencies. In addition, select a ferrite bead with adequate current rating to prevent distortion of the output signal.

Use an LC output filter if there are low frequency (< 1 MHz) EMI sensitive circuits and/or there are long leads from amplifier to speaker.

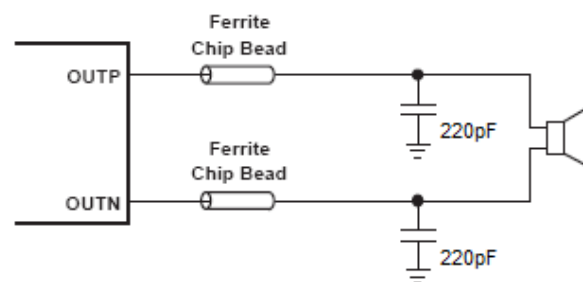

Ferrite Bead Filter to reduce EMI

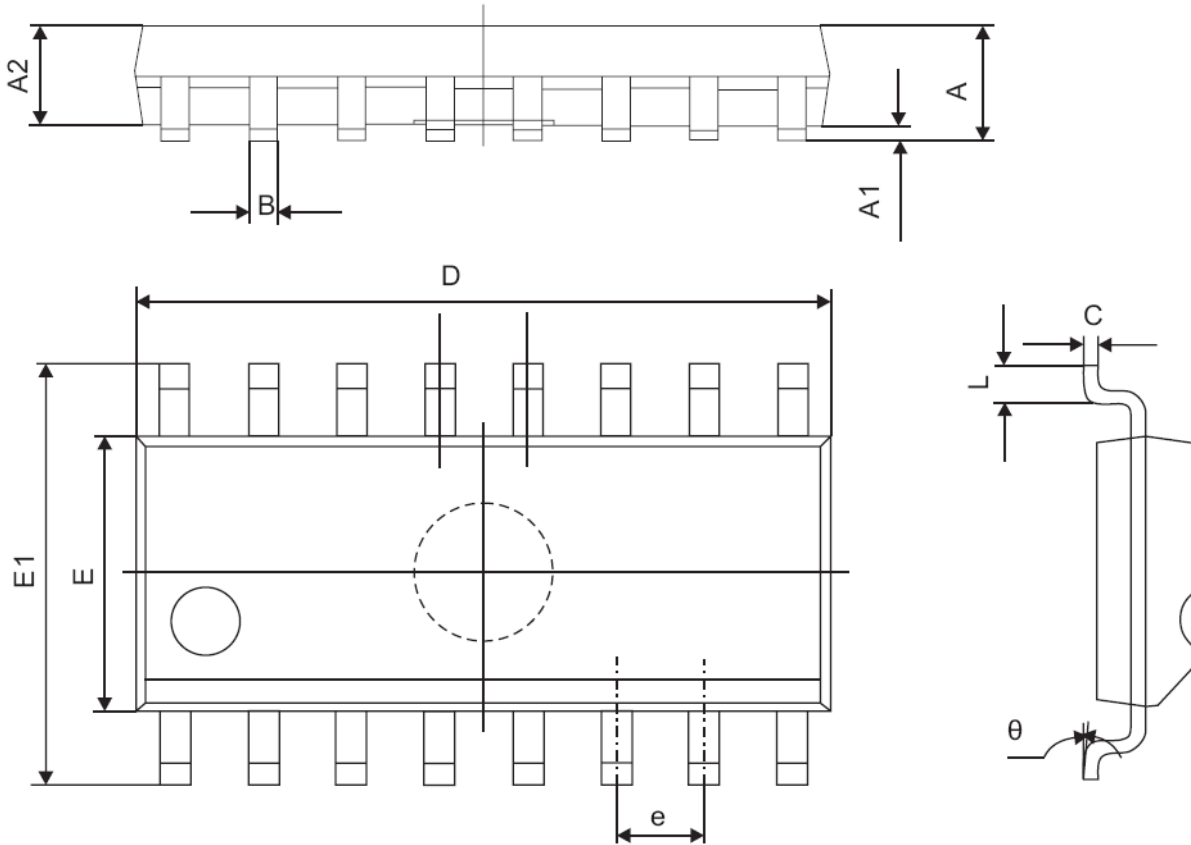
Outline Dimension
SOP-16

Symbol	Dimensions Millimeters	
	Min	Max
A	1.350	1.750
A1	0.100	0.250
A2	1.350	1.550
B	0.330	0.510
C	0.190	0.250
D	9.800	10.000
E	3.800	4.000
E1	5.800	6.300
e	1.270(TYP)	
L	0.400	1.270
θ	0°	8°