

ADJUSTABLE PRECISION ZENER SHUNT REGULATOR BL431

DESCRIPTION

The BL431 is a three-terminal adjustable regulator with a guaranteed thermal stability over applicable temperature ranges. The output voltage may be set to any value between V_{REF} (approximately 2.5V) and 36V with two external resistors. This device has typical dynamic output impedance of 0.2Ω . Active output circuitry provides a very sharp turn-on characteristic,

making these devices excellent replacement for zener diodes in many applications.

Outline Drawing

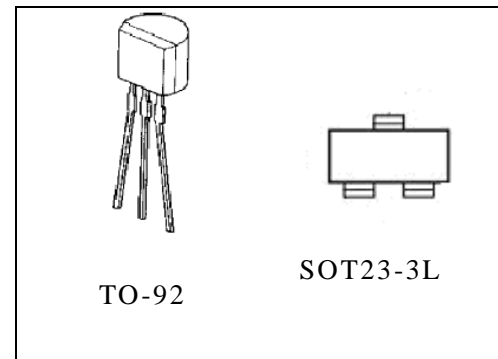

FEATURE

- Programmable output voltage to 36V
- Low dynamic output impedance 0.2Ω typical
- Sink current capability of 1.0mA to 100mA
- Equivalent full-range temperature coefficient of 50ppm/°C typical
- Temperature compensated for operation over full rated operating temperature range
- Low output noise voltage
- Fast turn on response

BLOCK DIAGRAM

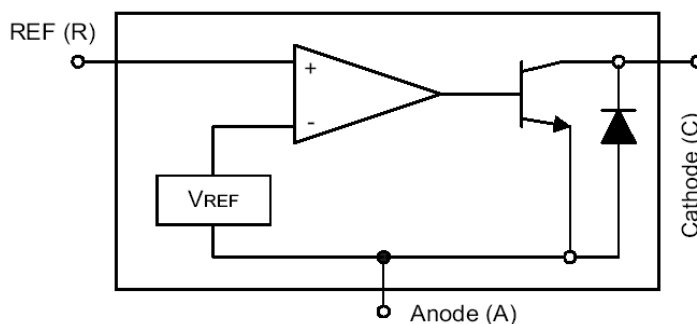

PIN CONNECTION

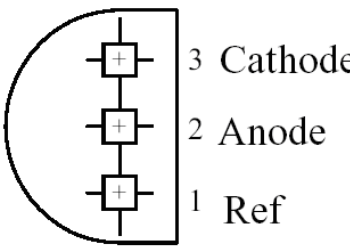
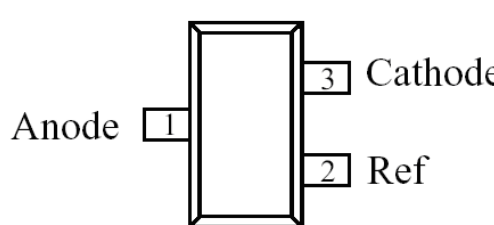
Order Number	Pin Configuration (Top View)
BL431 (T0-92)	
BL431 (SOT23-3L)	

ABSOLUTE MAXIMUM RATINGS

Operating temperature range applies unless otherwise specified.)

Characteristic	Symbol	Value	Unit
Cathode Voltage	Vka	37	V
Cathode Current Range (continuous)	Ika	-10~+150	mA
Reference Input Current Range	IREF	10	mA
Power Dissipation	PD	TO-92	770
		SOT23-3	230
Operating Temperature Range	Topr	0~+70	°C
Store temperature Range	Tstg	-65~+150	°C

ELECTRICAL CHARACTERISTICS (Ta=25°C unless otherwise specified)

Parameter	Conditions	Symbol	Min	Typ	Max	Unit	
Reference Voltage	V _Z =V _{REF} I _i =10mA	0.5%	2.487	2.500	2.513	V	
		1.0%	2.475	2.500	2.525		
Deviation of Reference Input Voltage Over Temperature	V _Z =V _{REF} , I _i =10mA	V _{dev}	-	8.0	17	mV	
Ratio of the Change in Reference Voltage to the Change in Cathode Voltage	I _Z =10mA	V _Z =V _{REF} ~10V	Δ V _{REF} /	-	-1.0	-2.7	mV/V
		V _Z =10~36V	Δ V _Z	-	-0.5	-2.0	
Reference Input Current	R ₁ =10kΩ, R ₂ =∞ I ₁ =10mA	I _{REF}	-	2.0	4.0	μA	
Deviation of Reference Input Current Over Temperature	R ₁ =10kΩ, R ₂ =∞ I ₁ =10mA	∞ I _{REF}	-	0.4	1.2	μA	
Minimum Cathode Current for Regulation	V _Z =V _{REF}	I _Z (min)	-	0.4	1.0	mA	
Off-State Current	V _Z =36V, V _{REF} =0V	I _Z (off)	-	0.05	1.0	μA	
Dynamic Output Impedance	V _Z =V _{REF} , I _Z =1 to 100mA, f<1.0kHz	R _Z	-	-	0.50	Ω	

TEST CIRCUIT

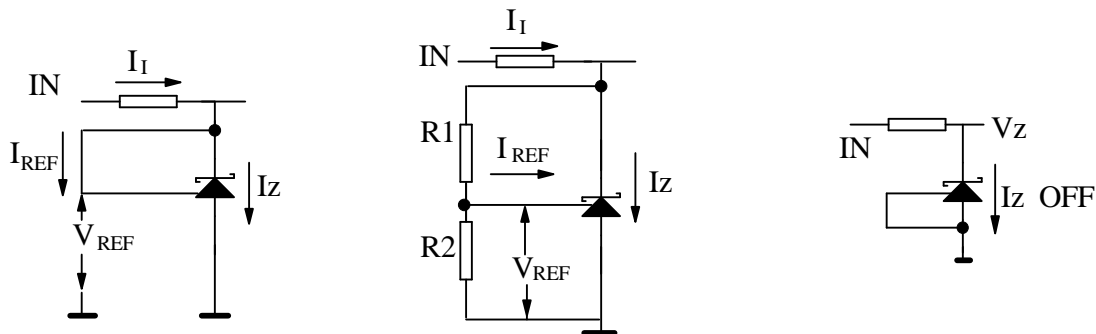

Note: $V_Z = V_{REF}(1 + R_1/R_2) + I_{REF} * R_1$

1. Test circuit for $V_Z = V_{REF}$ 2. Test circuit for $V_Z > V_{REF}$ 3. Test circuit for off-state current

APPLICATION CIRCUIT

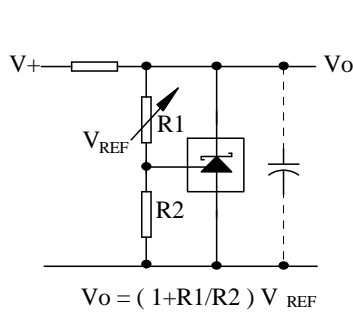

1. Shunt Regulator

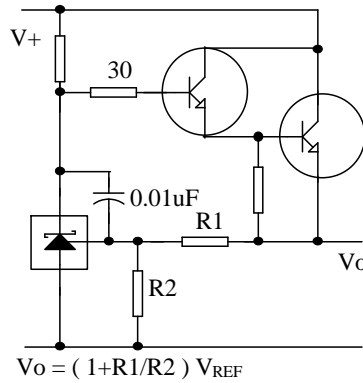

2. Series Regulator

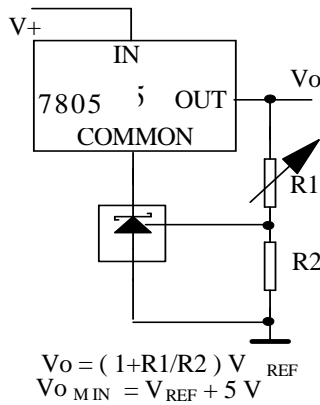

3. Output Control of a Three Terminal Fixed Regulator

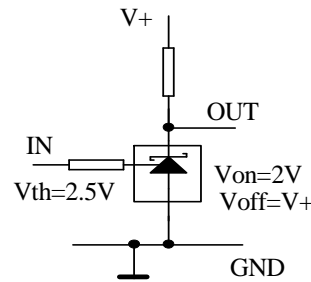

4. Single Supply Comparator with Temperature Compensated Threshold

5. Higher Current Shunt Regulator

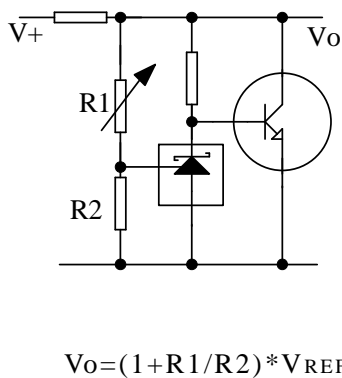

6. Crow Bar

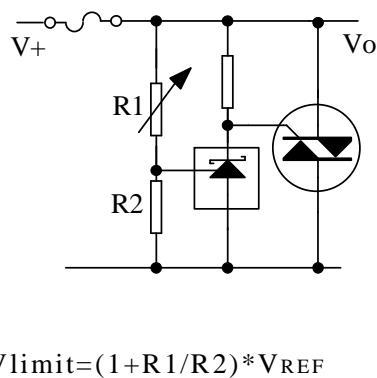

CHARACTERISTIC CURVES

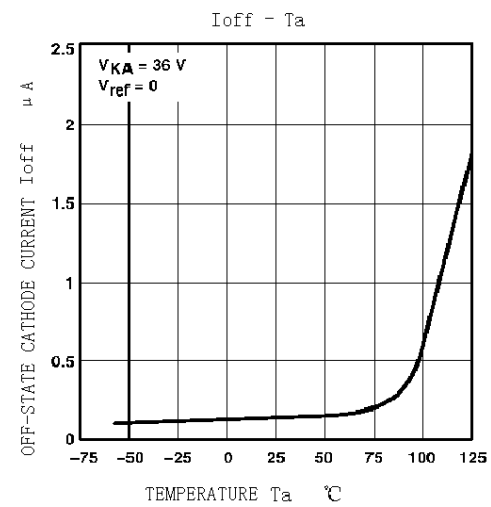
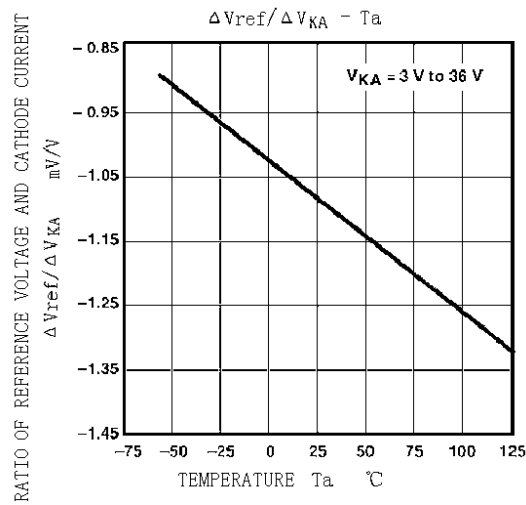
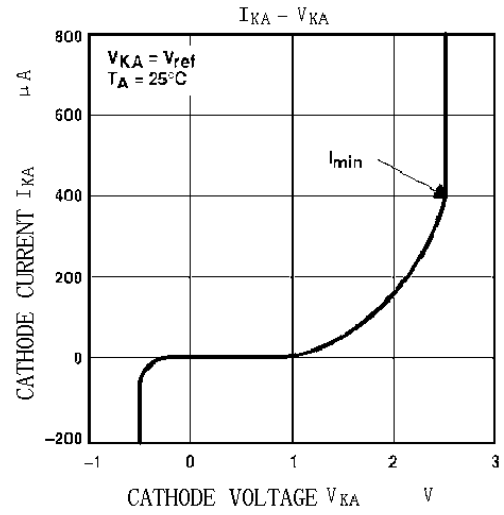
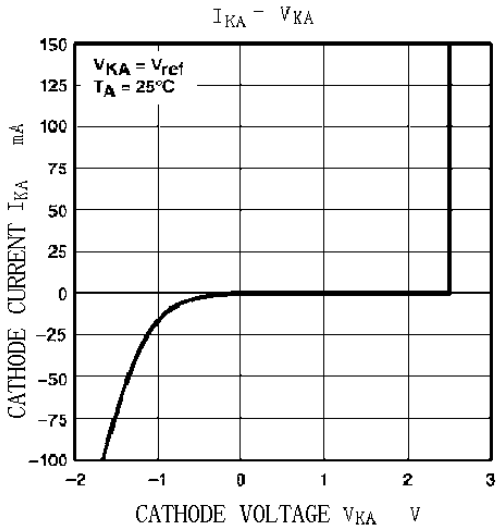
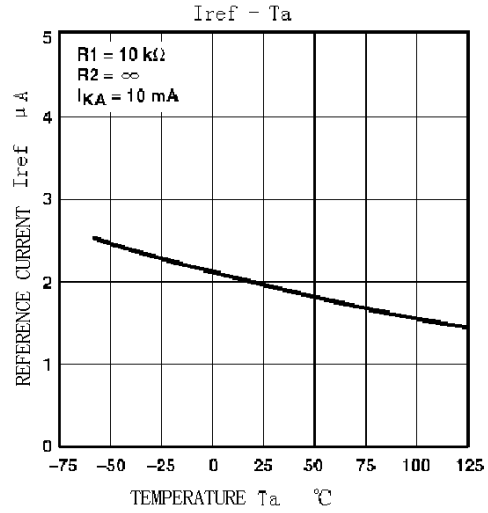
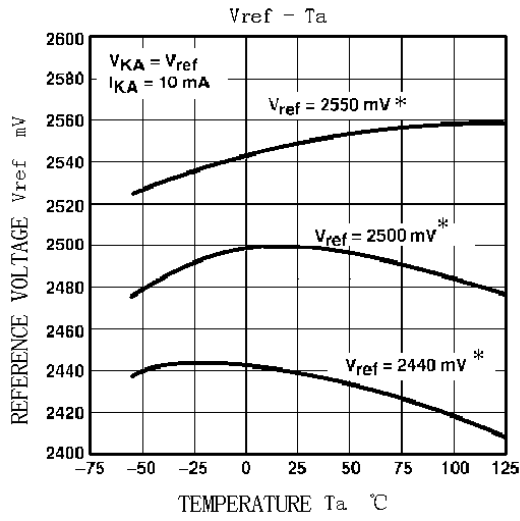

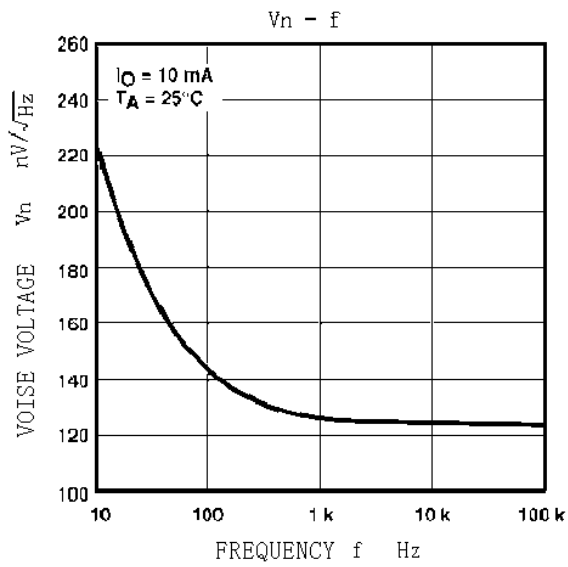

STABILITY BOUNDARY CONDITIONS:

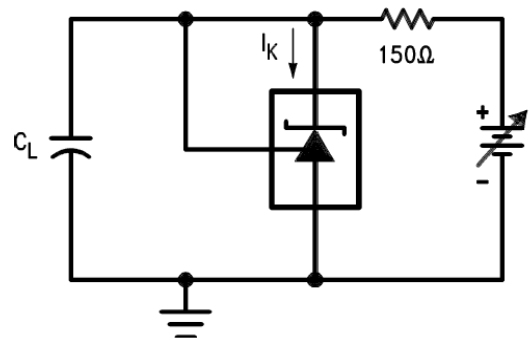
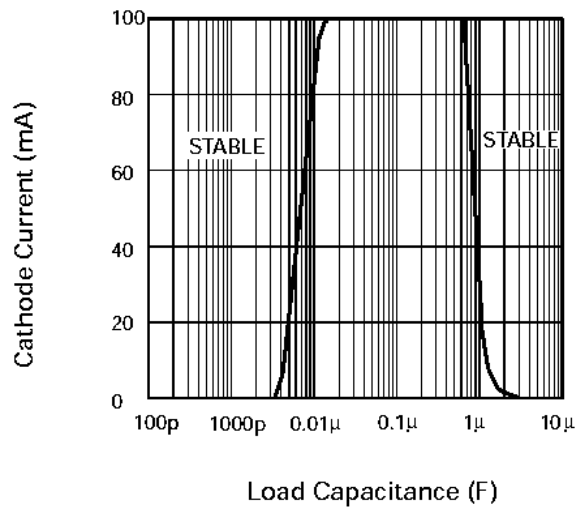

Test Circuit for Stability Boundary:

Appendix:

TO-92 Package Outline Dimension:

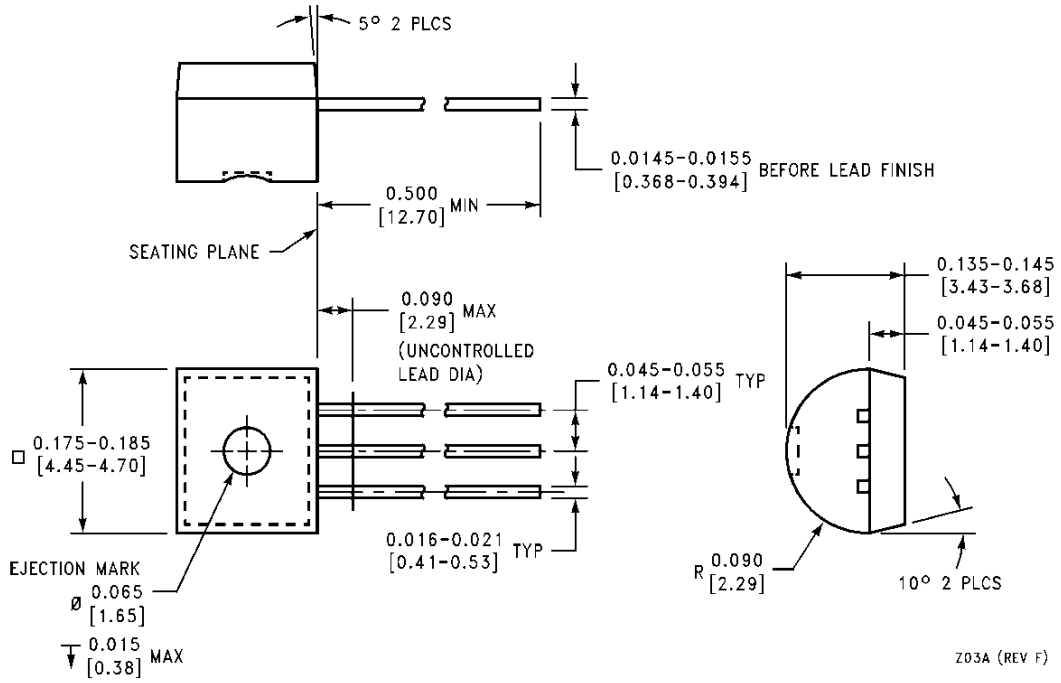

TO-92:

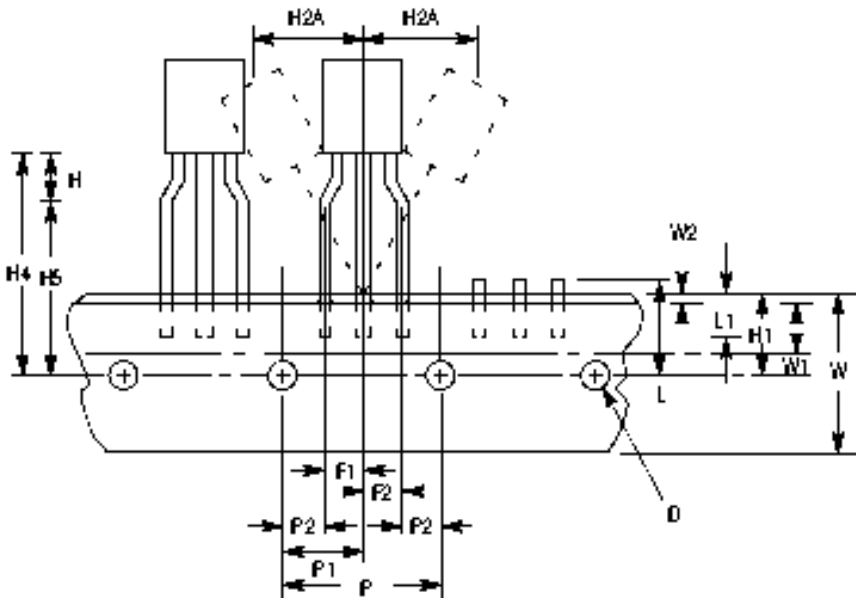

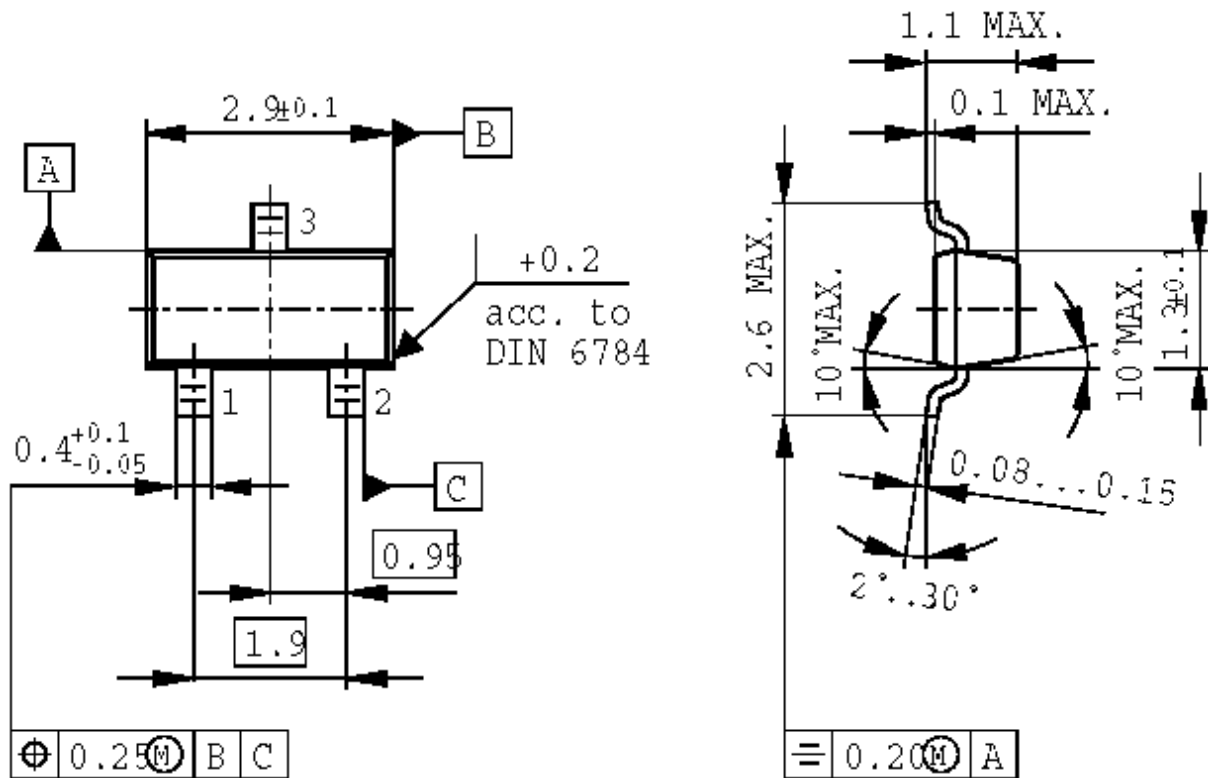
SOT-23-3 Package Outline Dimension:

Taping Diagram:

	(mm)
ΔA	0 ± 1.0
ΔB	$0 + 1.0$
D	4.0 ± 0.2
F1, F2	$2.5 + 0.4$ -0.1
H	21.0max
H1	16 ± 0.5
H2	$9.0 + 0.5$
P	12.7 ± 0.3
P1	6.35 ± 0.5
T	1.5max
W	$18.0 + 1.0$ -0.5
W1	6.0 ± 0.5
W2	1.0max

