

## Small Package, High Performance, Asynchronous Boost For 10 WLED Driver **ME2212**

### General Description:

The **ME2212** is a high frequency, asynchronous boost converter. The internal MOSFET can support up to 10 White LEDs for backlighting and OLED power application, and the internal soft start function can reduce the inrush current. The device operates with 1-MHz fixed switching frequency to allow small external components and to simplify possible EMI problems. Moreover, the IC comes with 46V over voltage protection to allow inexpensive and small-output capacitors with lower voltage ratings. The LED current is initially set with the external sense resistor  $R_s$ .

### Features:

- VIN Operating Range : 2.5V to 5.5V
- Internal Power N-MOSFET Switch
- Wide Range for PWM Dimming (100Hz to 200kHz)
- 1MHz Switching Frequency
- Minimize the External Component Counts
- Internal Soft Start
- Internal Compensation
- Under Voltage Protection
- Over Voltage Protection
- Over Temperature Protection

### Applications:

- Cellular Phones
- Digital still cameras
- PDAs and Smart Phones and MP3 and OLED.
- Probable Instruments

### $R_s$ Resistor Value Selection:

TYP. ( $\Omega$ )	$I_{LED}$ (mA)
10	20

### Typical Application:

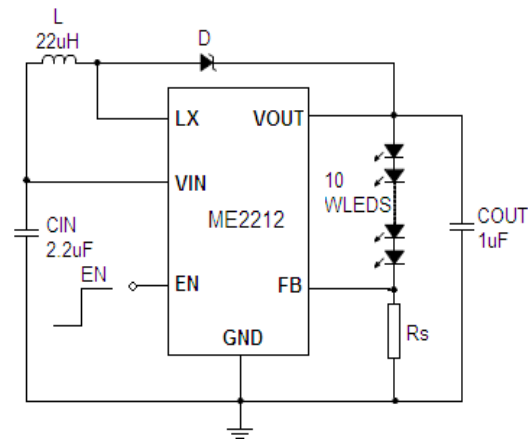

$I_{LED} = 20\text{mA}$ ,  $R_s = 10\Omega$

## Pin Configuration & Marking Information:



SOT23-6

## Pin information:

Pin Number	Name	Function
1	LX	Switch
2	GND	Ground
3	FB	Feedback
4	EN	Chip Enable
5	VOUT	Output
6	VIN	Input

## Absolute Maximum Ratings:

Parameter	Symbol	Ratings	Units
Input Voltage	$V_{IN}$	-0.3V~6V	V
LX Pin Voltage	LX	-0.3V~6V	V
FB Pin Voltage	FB	-0.3V~6V	V
Operating Temperature Range	$T_{OPR}$	-40°C~85°C	°C
Storage Temperature Range	$T_{STG}$	-65°C~125°C	°C
Lead Temperature (Soldering, 10 sec)	$T_L$	260°C	°C
Internal Power Dissipation (SOT23-6)	$P_D$	400	mW

**Function Block Diagram:**

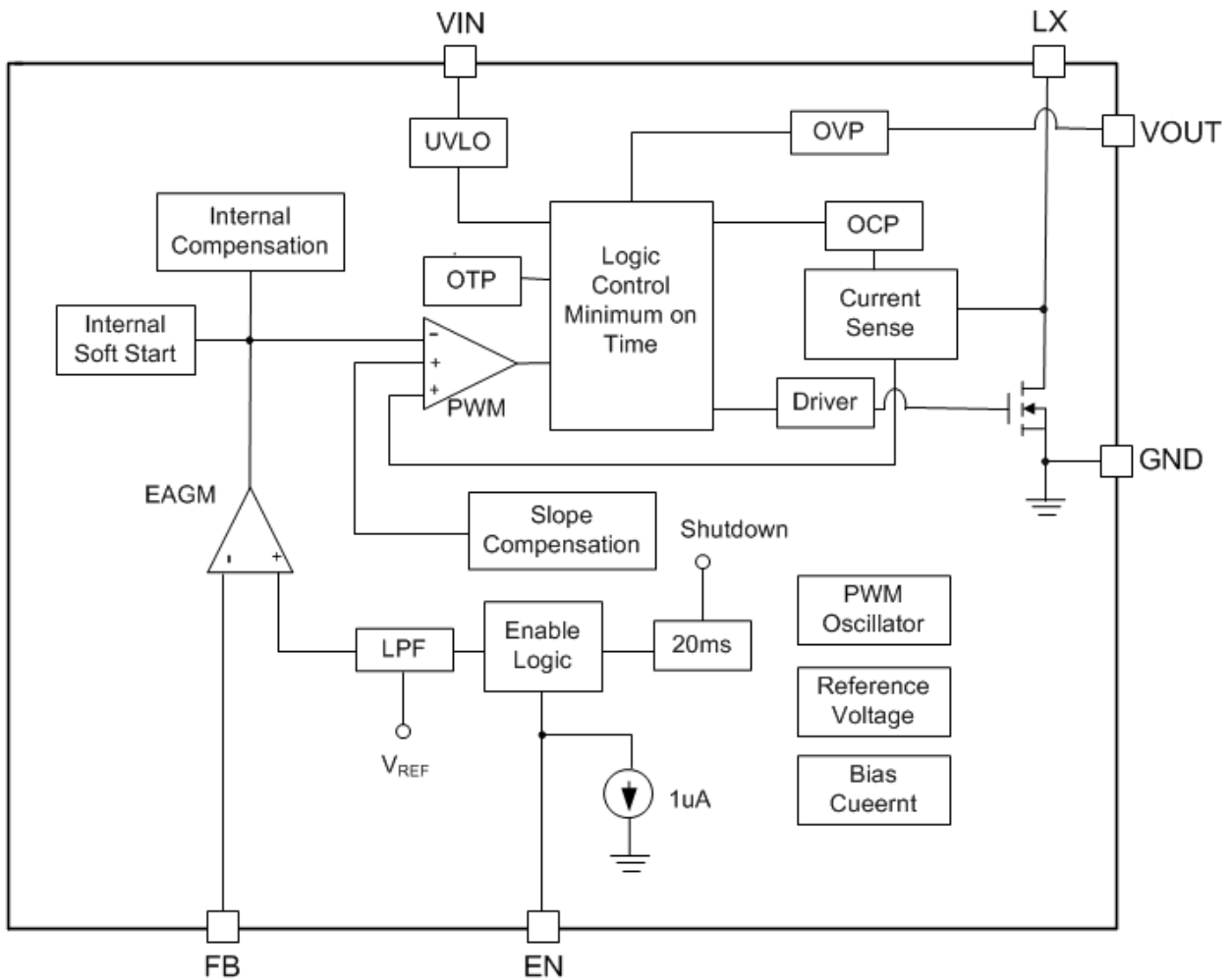

## Electrical Characteristic

T=25°C,  $V_{IN}=V_{EN}=3.7V$ , L=22uH,  $C_{in}=2.2\ \mu F$ ,  $C_{out}=1\ \mu F$ , unless otherwise noted.

Parameter	Symbol	Condition	Min	Typ	Max	Unit
Input Voltage Range	$V_{IN}$		2.5	3.7	5.5	V
Under Voltage Lock Out	$V_{UVLO}$		2	2.2	2.45	V
UVLO Hystersis				0.1		V
Supply Current	ISS	No external Component		0.8	1.5	mA
Shutdown Current	$I_{SHDN}$	No external Component $V_{EN}=0V$	1	3	5	uA
Oscillator Frequency	$F_{OSC}$		0.85	1.1	1.5	MHz
Maximum Duty Cycle			90	92		%
Feedback Voltage	$V_{FB}$		190	200	210	mV
On Resistance	$R_{DS(ON)}$			0.7	1.2	$\Omega$
EN Threshold	Logic-High Voltage	$V_{IH}$	1.6			V
	Logic-Low Voltage	$V_{IL}$			0.9	V
Over-Voltage Threshold	$V_{OCP}$		42	46	50	V
Over-Current Threshold	$I_{OCP}$		1	1.2		A
Efficiency	$\eta$	$I_{LED}=20mA$		85		%
Over Temperature Shutdown	OTS			150		$^{\circ}C$

## Typical Operating Characteristics

### 1. Efficiency vs. Output Current ( 3 White LEDs )

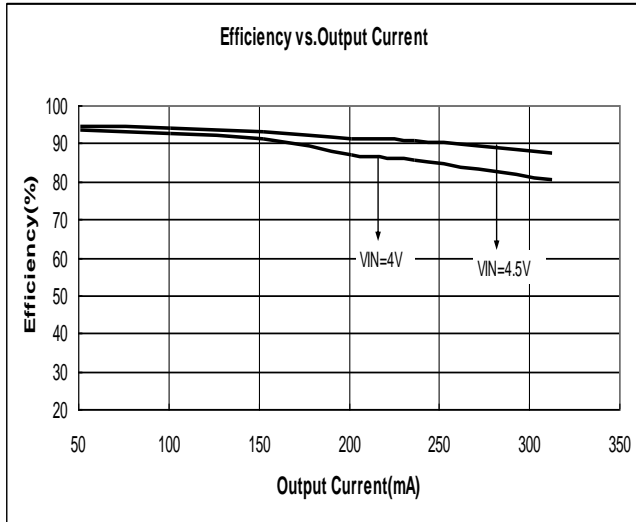

### 2. Efficiency vs. Input Voltage ( 10 White LEDs )

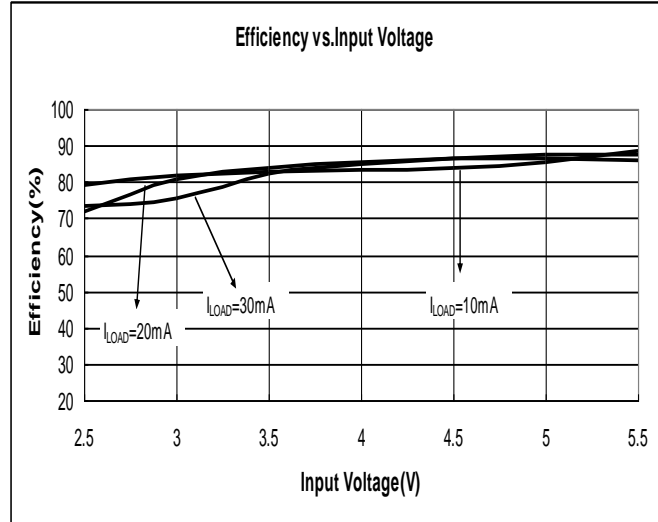

### 3. Frequency vs. Input Voltage ( ILED=20mA )

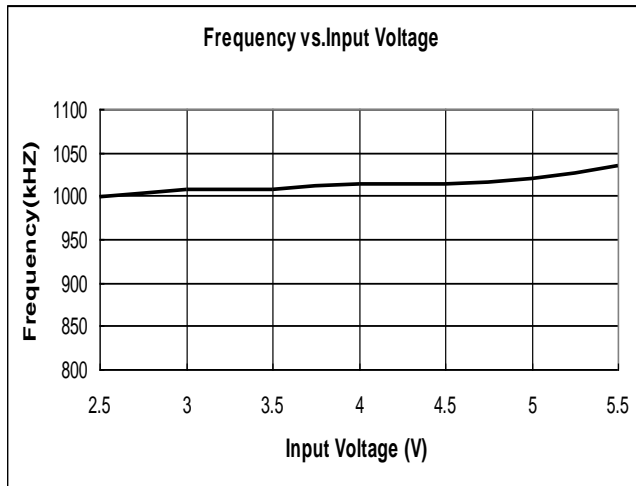

### 4. Frequency vs. Temperature ( VIN=3.7V, ILED=20mA )

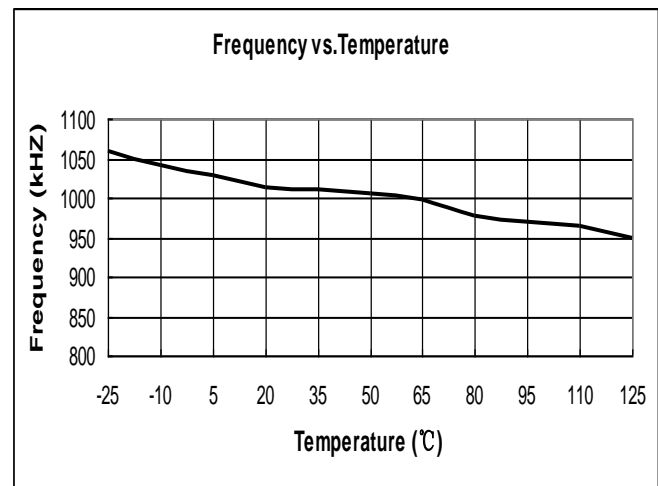

5.  $V_{FB}$  vs. Input Voltage  
(10 White LEDs,  $I_{LED}=20mA$ )

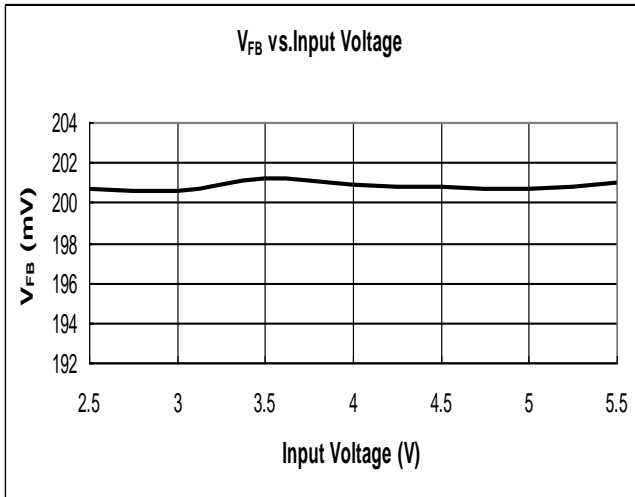

6.  $V_{FB}$  vs. Temperature  
( $I_{LED}=20mA$ )

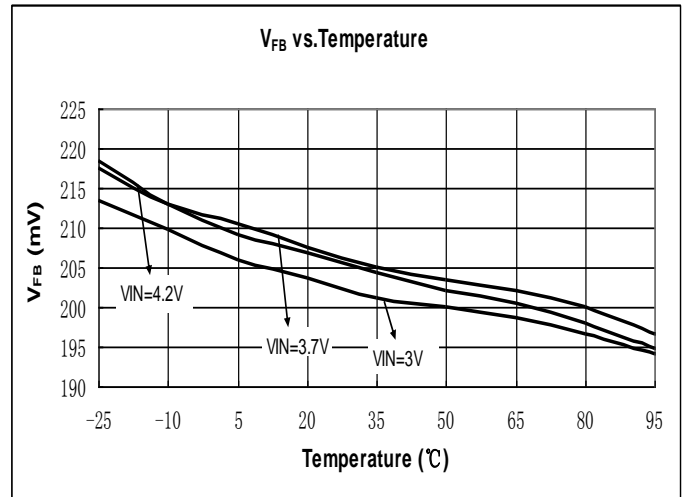

7.  $V_{FB}$  vs. Output Current  
(10 White LEDs )

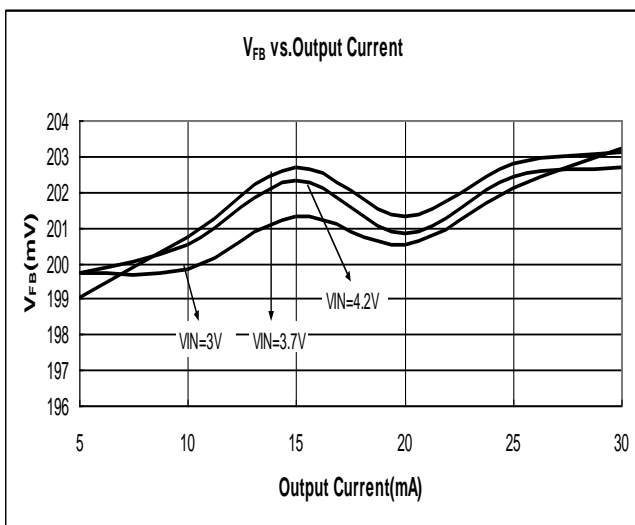

8. Enable Voltage vs. Input Voltage  
(10 White LEDs )

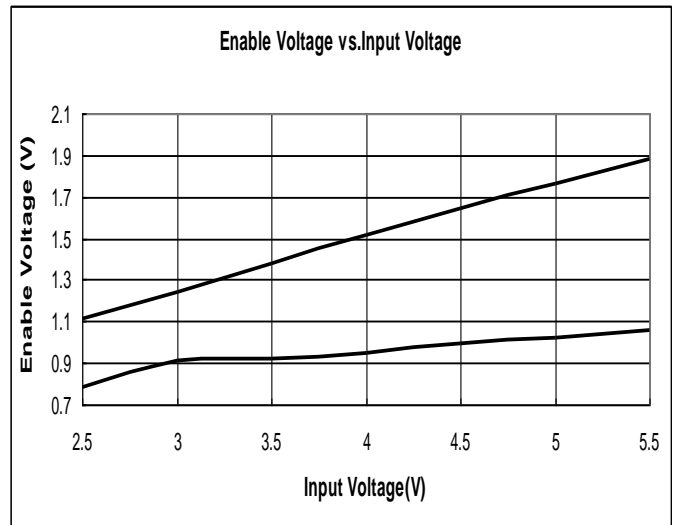

Package Information

• SOT-23-6

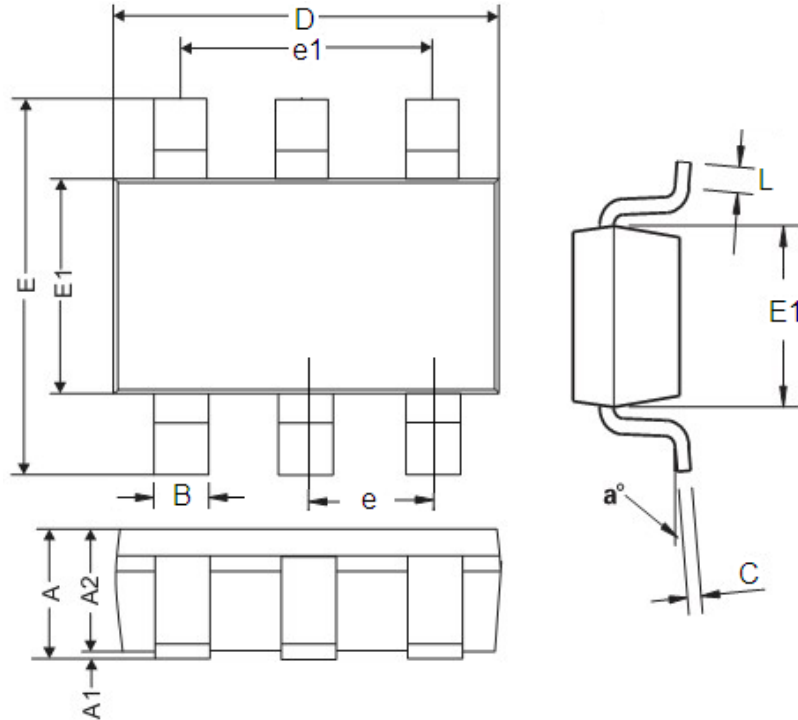

DIM	Millimeters		Inches	
	Min	Max	Min	Max
A	0.9	1.45	0.0354	0.0570
A1	0	0.15	0	0.0059
A2	0.9	1.3	0.0354	0.0511
B	0.2	0.5	0.0078	0.0196
C	0.09	0.26	0.0035	0.0102
D	2.7	3.10	0.1062	0.1220
E	2.2	3.2	0.0866	0.1181
E1	1.30	1.80	0.0511	0.0708
e	0.95REF		0.0374REF	
e1	1.90REF		0.0748REF	
L	0.10	0.60	0.0039	0.0236
a°	0°	30°	0°	30°