

PFM Step-up DC/DC Converter, ME2110 Series

General Description

ME2110 Series is a PFM Step-up DC/DC converter IC with low supply current by CMOS process. High frequency noise that occurs during switching is reduced by using advanced circuit designed, output voltage is programmable in 0.1V steps between 1.8~6.0V. A low ripple, high efficiency step-up DC/DC converter can be constructed of ME2110Xxx with only three external components. Also available is a CE (chip enable) function that reduce power dissipation during shut-down mode. ME2110Xxx is suitable for use with battery-powered instruments with low noise and low supply current.

Features

- Low ripple and low noise
- Operating voltage range: 0.9V~6.0V
- Output voltage range: 1.8V~6.0V(step 0.1V)
- Output voltage accuracy: $\pm 2\%$
- Output Current: If $V_{IN}=1.2V$ and $V_{OUT}=1.9V$, then $I_{OUT}=100mA$
- Low start voltage: $\leq 0.9V$ (at $I_{OUT}=1mA$)
- Maximum oscillator frequency : 360KHz (TYP. ME2110C25)
- High Efficiency: 85% (TYP.)
- Package: SOT89-3, SOT23-5

Selection Guide

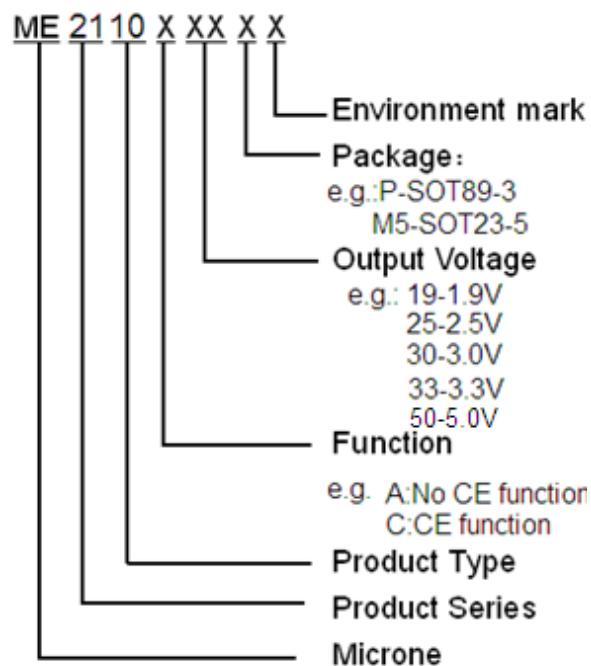

Typical Application

- Power source for battery-powered equipment
- Power source for wireless mouse, wireless keyboard, toys, cameras, camcorders, VCRs, PDAs, and hand-held communication equipment
- Power source for appliances which require higher cell voltage than that of batteries used in the appliances

Pin Configuration

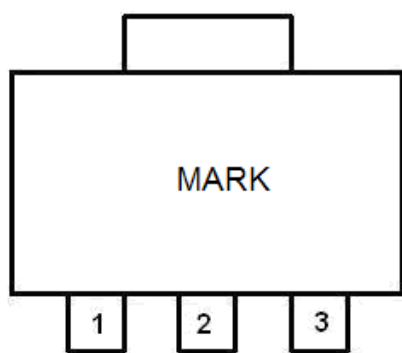

SOT89-3

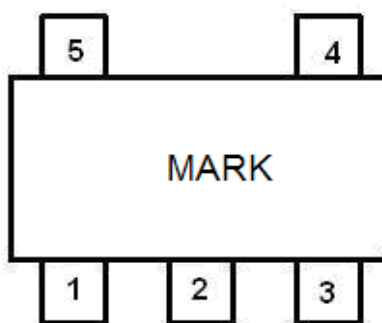

SOT23-5

Pin Assignment

TYPE	POSTFIX	PACKAGE	SWITCHING TRANSISTOR	CE FUNCTION	FEATURE
ME2110Axx	P	SOT89-3	Build in Transistor	No	Lx
ME2110Cxx	M5	SOT23-5	Build in Transistor	Yes	Lx CE

ME2110AXX

PIN Number	Pin Name	Function
1	GND	Ground
2	V _{OUT}	Output voltage monitor, IC internal power supply
3	Lx	Switch

ME2110CXX

PIN Number	Pin Name	Function
SOT23-5		
1	CE	Chip enable
2	V _{OUT}	Output voltage monitor, IC internal power supply
3	NC	NC
4	GND	Ground
5	Lx	Switch

Absolute Maximum Ratings

PARAMETER		SYMBAL	RATING	UNIT
V _{IN} Input Voltage		V _{IN}	6.5	V
Lx Pin voltage		V _{LX}	6.5	V
CE Pin voltage		V _{CE}	-0.3~ V _{OUT} +0.3	V
Lx Pin current	V _{OUT} =1.9V	I _{LX}	800	mA
	V _{OUT} =2.5V,3.0V,3.3V	I _{LX}	1300	mA
	V _{OUT} =5V	I _{LX}	2000	mA
Vdd input voltage		V _{dd}	6.5	V
Continuous Total Power Dissipation	SOT89-3	Pd	500	mW
	SOT23-5	Pd	300	mW
Operating Ambient Temperature		T _{Opr}	-25~+85	°C
Storage Temperature		T _{stg}	-40~+125	°C
Soldering temperature and time		T _{solder}	260°C, 10s	

Block Diagram

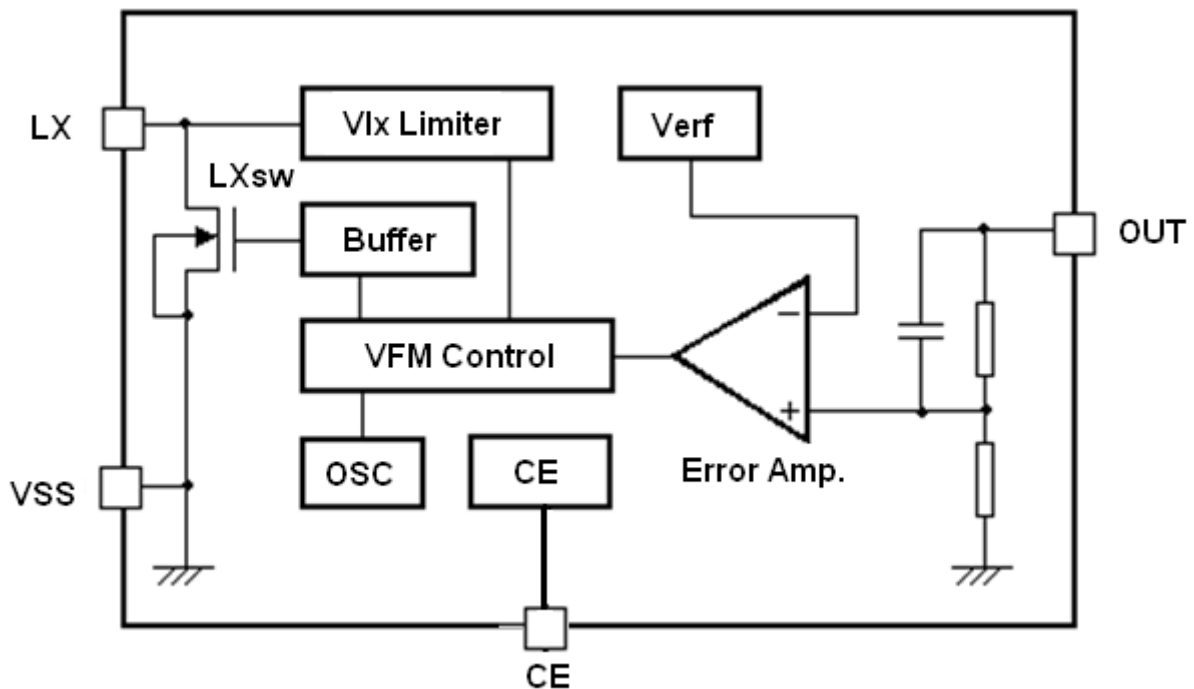

Electrical Characteristics

ME2110A19 $F_{osc}=150KHz$

($V_{IN}=V_{OUT} \times 0.6$, $I_{OUT}=10mA$, $T_{opt}=25^{\circ}C$. Unless otherwise specified)

SYMBOL	PARAMETER	CONDITIONS	MIN	TYP	MAX	UNITS
V_{OUT}	Output Voltage		$V_{OUT} \times 0.98$	V_{OUT}	$V_{OUT} \times 1.02$	V
V_{start}	Oscillation Start-up Voltage	$I_{OUT}=1mA$, $V_{IN}: 0 \rightarrow 2V$	-	0.80	0.90	V
V_{hold}	Oscillation Hold Voltage	$I_{OUT}=1mA$, $V_{IN}: 2 \rightarrow 0V$	-	0.45	-	V
I_{DD1}	Supply Current 1	No external component $V_{OUT}=V_{OUT} \times 0.95$,	-	27	-	μA
I_{DD2}	Supply Current 2	$V_{OUT}=V_{OUT}+0.5V$	-	4.5	-	μA
I_{LX}	Lx Switching Current	$V_{LX}=0.4V$, $V_{OUT}=V_{OUT} \times 0.95$	-	100	-	mA
I_{LXleak}	Lx Leakage Current	$V_{OUT}=V_{LX}=6V$	-	-	0.5	μA
F_{osc}	Oscillation Frequency	$V_{OUT}=\text{set } V_{OUT} \times 0.95$	-	150	-	KHz
Maxdty	Duty Ratio	on(V_{LX} "L")side	-	84	-	%
EFFI	Efficiency		-	85	-	%

ME2110C25 $F_{osc}=360KHz$

($V_{IN}=V_{OUT} \times 0.6$, $V_{CE}=V_{OUT}$, $I_{OUT}=10mA$, $T_{opt}=25^{\circ}C$. Unless otherwise specified)

SYMBOL	PARAMETER	CONDITIONS	MIN	TYP	MAX	UNITS
V_{OUT}	Output Voltage		$V_{OUT} \times 0.98$	V_{OUT}	$V_{OUT} \times 1.02$	V
V_{start}	Oscillation Start-up Voltage	$I_{OUT}=1mA$, $V_{IN}: 0 \rightarrow 2V$	-	0.84	0.90	V
V_{hold}	Oscillation Hold Voltage	$I_{OUT}=1mA$, $V_{IN}: 2 \rightarrow 0V$	-	0.33	-	V
I_{DD1}	Supply Current 1	No external component $V_{OUT}=V_{OUT} \times 0.95$,	-	85	-	μA
I_{DD2}	Supply Current 2	No external component $V_{OUT}=V_{OUT}+0.5V$	-	7	-	μA
I_{DD3}	Supply Current 3	No external component $V_{OUT}=V_{OUT}+0.5V$ $V_{CE}=0V$	-	-	1.0	μA
I_{LX}	Lx Switching Current	No external component $V_{LX}=0.4V$ $V_{OUT}=\text{set } V_{OUT} \times 0.95$	-	100	-	mA
I_{LXleak}	Lx Leakage Current	$V_{OUT}=V_{LX}=6V$	-	-	0.5	μA

F_{osc}	Oscillation Frequency	$V_{OUT} = \text{set } V_{OUT} \times 0.95$	-	360	-	KHz
Maxdty	Duty Ratio	on(V_{LX} “L”)side	-	77	-	%
EFFI	Efficiency		-	85	-	%

ME2110C33 $F_{osc}=360\text{KHz}$

($V_{IN} = V_{OUT} \times 0.6$, $V_{CE} = V_{OUT}$, $I_{OUT} = 10\text{mA}$, $T_{opt} = 25^\circ\text{C}$. Unless otherwise specified)

SYMBOL	PARAMETER	CONDITIONS	MIN	TYP	MAX	UNITS
V_{OUT}	Output Voltage		$V_{OUT} \times 0.98$	V_{OUT}	$V_{OUT} \times 1.02$	V
V_{start}	Oscillation Start-up Voltage	$I_{OUT} = 1\text{mA}$, $V_{IN}: 0 \rightarrow 2\text{V}$	-	0.84	0.90	V
V_{hold}	Oscillation Hold Voltage	$I_{OUT} = 1\text{mA}$, $V_{IN}: 2 \rightarrow 0\text{V}$	-	0.33	-	V
I_{DD1}	Supply Current 1	No external component $V_{OUT} = V_{OUT} \times 0.95$,	-	110	-	μA
I_{DD2}	Supply Current 2	No external component $V_{OUT} = V_{OUT} + 0.5\text{V}$	-	7	-	μA
I_{DD3}	Supply Current 3	No external component $V_{OUT} = V_{OUT} + 0.5\text{V}$ $V_{CE} = 0\text{V}$	-	-	1.0	μA
I_{LX}	Lx Switching Current	No external component $V_{LX} = 0.4\text{V}$ $V_{OUT} = \text{set } V_{OUT} \times 0.95$	-	100	-	mA
I_{LXleak}	Lx Leakage Current	$V_{OUT} = V_{LX} = 6\text{V}$	-	-	0.5	μA
F_{osc}	Oscillation Frequency	$V_{OUT} = \text{set } V_{OUT} \times 0.95$	-	360	-	KHz
Maxdty	Duty Ratio	on(V_{LX} “L”)side	-	77	-	%
EFFI	Efficiency		-	85	-	%

ME2110C50 $F_{osc}=310\text{KHz}$

($V_{IN} = V_{OUT} \times 0.6$, $V_{CE} = V_{OUT}$, $I_{OUT} = 10\text{mA}$, $T_{opt} = 25^\circ\text{C}$. Unless otherwise specified)

SYMBOL	PARAMETER	CONDITIONS	MIN	TYP	MAX	UNITS
V_{OUT}	Output Voltage		$V_{OUT} \times 0.98$	V_{OUT}	$V_{OUT} \times 1.02$	V
V_{start}	Oscillation Start-up Voltage	$I_{OUT} = 1\text{mA}$, $V_{IN}: 0 \rightarrow 2\text{V}$	-	0.85	0.90	V
V_{hold}	Oscillation Hold Voltage	$I_{OUT} = 1\text{mA}$, $V_{IN}: 2 \rightarrow 0\text{V}$	-	0.38	-	V

I_{DD1}	Supply Current 1	No external component $V_{OUT}=V_{OUT} \times 0.95,$	-	165	-	μA
I_{DD2}	Supply Current 2	No external component $V_{OUT}=V_{OUT}+0.5V$	-	8	-	μA
I_{DD3}	Supply Current 3	No external component $V_{OUT}=V_{OUT}+0.5V$ $V_{CE}=0V$	-	-	1.0	μA
I_{LX}	Lx Switching Current	No external component $V_{LX}=0.4V$ $V_{OUT}= \text{set } V_{OUT} \times 0.95$	-	110	-	mA
I_{LXleak}	Lx Leakage Current	$V_{OUT}=V_{LX}=6V$	-	-	0.5	μA
F_{osc}	Oscillation Frequency	$V_{OUT}=\text{set } V_{OUT} \times 0.95$	-	310	-	KHz
Maxdty	Duty Ratio	on(V_{LX} “L”)side	-	74	-	%
EFFI	Efficiency		-	85	-	%

- Note:
- 1、Diode use Schottky diode such as IN5817 or IN5819 (forward voltage drop:0.2V)
 - 2、Inductor: 22 μH ($r < 0.5\Omega$)
 - 3、Capacitor: Tantalum type 100 μF
 - 4、When you measure frequency and duty ratio, only to connect the resistance of 1.2K between L_x and V_{OUT} .

Operation Description

ME2110 step-up DC/DC converter charges energy in the inductor when Lx Transistor is on, and discharges the energy with the addition of the energy from input power source thereto, so that a higher output voltage than the input voltage is obtained. Following is the operation diagram.

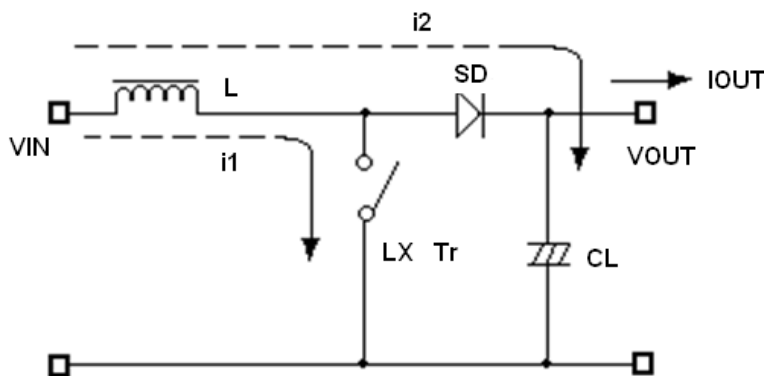

Switching DC/DC Step up Converter operating process

Selection of Peripheral Components and Application Notes

- Power source for battery-powered equipment
- Power source for wireless mouse, wireless keyboard, toys, cameras, camcorders, VCRs, PDAs, and hand-held communication equipment
- Power source for appliances which require higher cell voltage than that of batteries used in the appliances
- Peripheral components should be selected carefully because they are greatly affect the performances of ME2110:
 - ✧ Use capacitor with a capacity of 10 μ F or more (too small capacity will lead to high output ripple), and with good frequency characteristics (it is better to use Tantalum type). Besides, it is recommended the use of a capacitor with an allowable voltage which is at least three times the output set voltage. This is because there may be the case where a spike-shaped high voltage is generated by the inductor when Lx transistor is turned OFF.
 - ✧ Choose such an inductor that has sufficiently small d.c. resistance and large allowable current, and hardly reaches magnetic saturation. When the inductance value of the inductor is small, there may be the case where ILX exceeds the absolute maximum ratings at the maximum load.
 - ✧ Use a diode of a Schottky type with high switching speed.
- PCB Layout:
 - ✧ Set external components as close as possible to the IC and minimize the connection between the components and the IC. In particular, when an external component is connected to V_{OUT} Pin, make minimum connection with the capacitor.
 - ✧ Make V_{ss} pin sufficient grounding, otherwise, the zero level within IC will varied with the switching current. This may result in unstable operation of IC.

Typical Applications

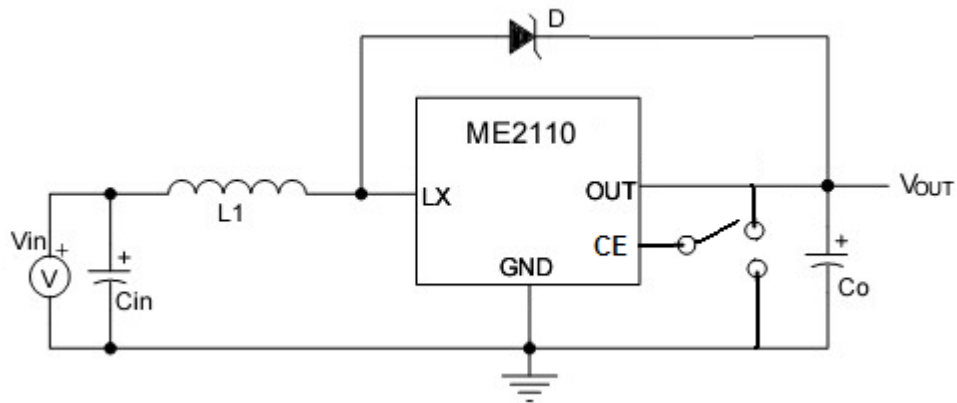

For use build in transistor

Components

- Inductor: 22 μ H(Sumida)
- Diode: IN5817、IN5819
- Capacitor: 100 μ F/16V(Tantalum Capacitor)

Type Characteristics (Ta = 25 °C)

ME2110A19

(1)

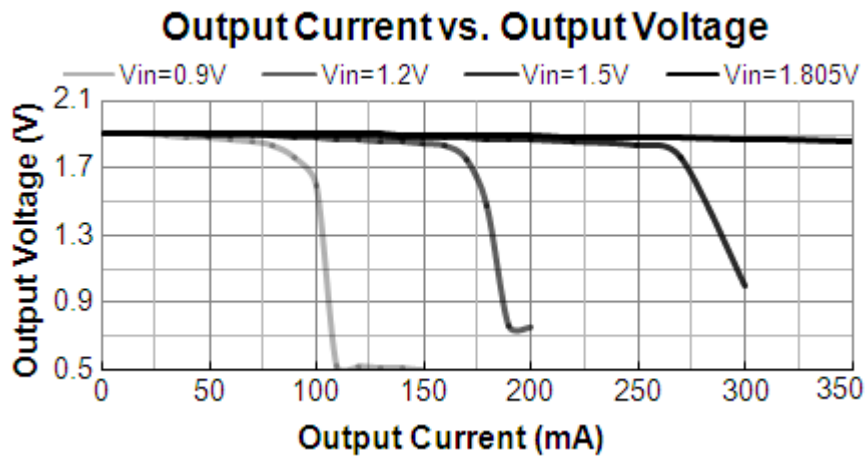

(2)

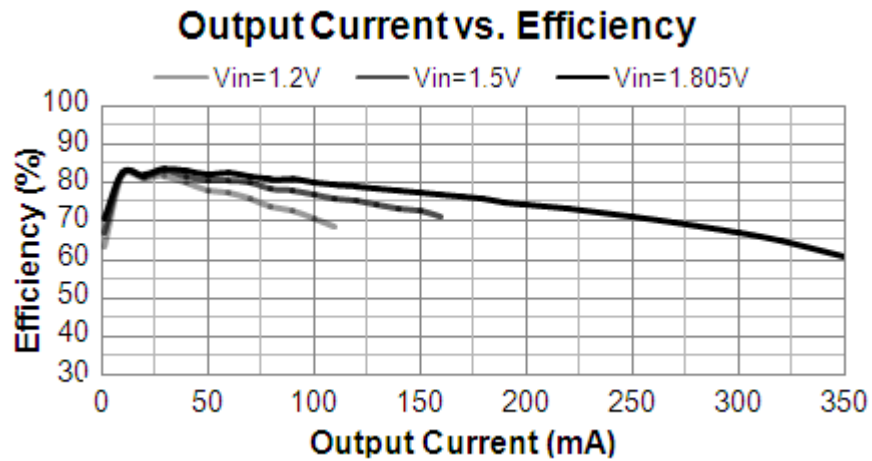

(3)

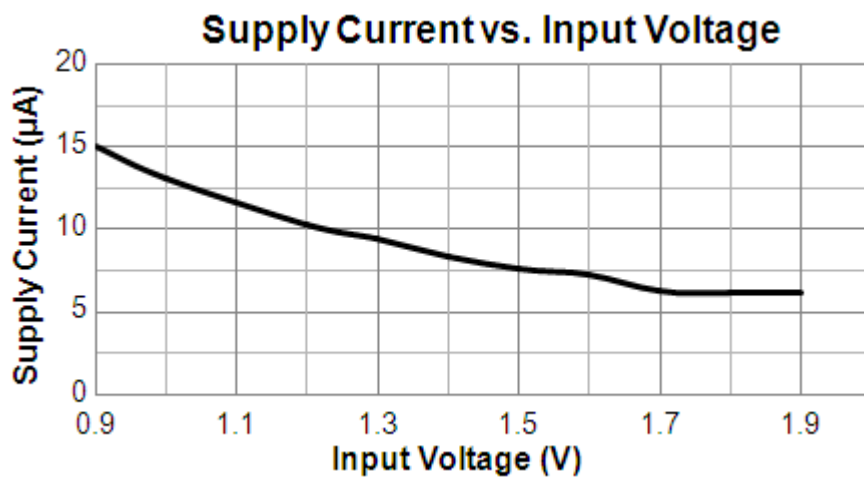

ME2110C33

(1)

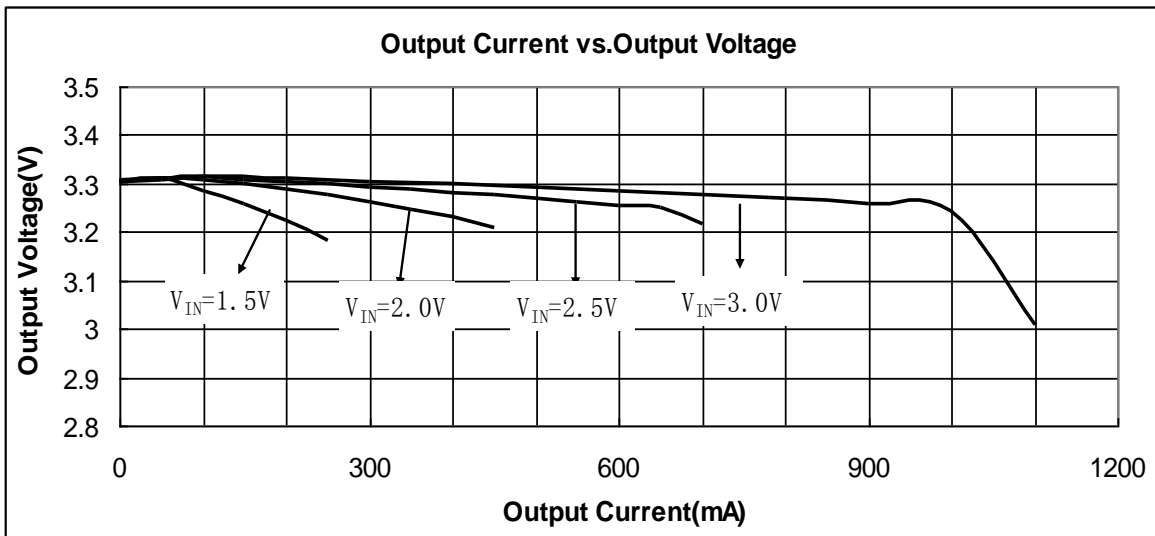

(2)

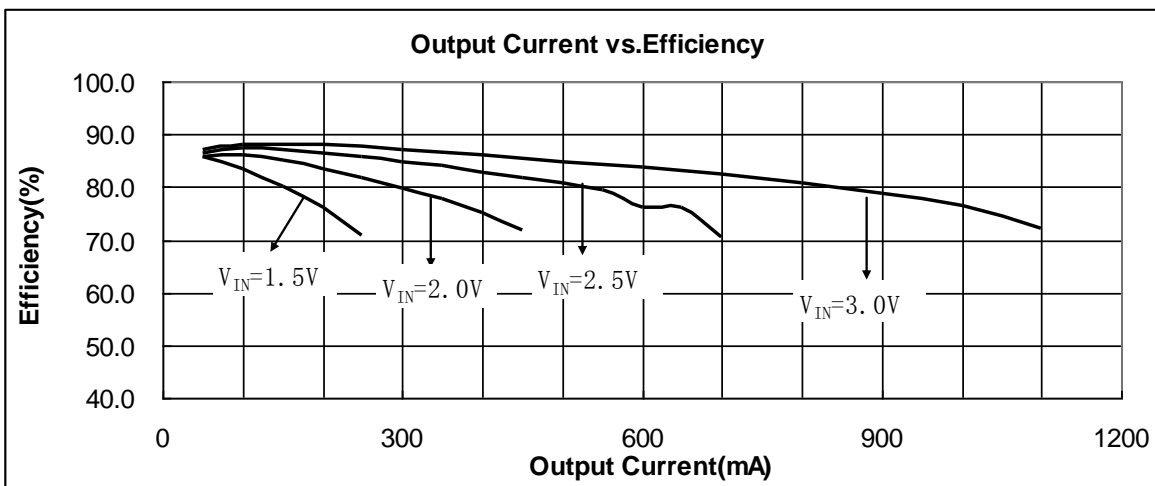

(3)

