

Outline:

BL8506D is a series of high precision voltage detector with ultra low current consumption (250nA typ. at $V_{DD}=V_{TH}+1V$). It can work at very low voltage, which makes it perfect for system reset.

BL8506D is composed of high precision voltage reference, comparator, output driver and resistor array. Internally preset detect voltage has a low temperature drift and requires no external trimming.

Two type of output, CMOS and N-channel open-drain are available.

BL8506D is available in SOT-89-3, SOT-23-3 TO92, SOT23-5 packages which is Pb free.

Features:

- High-precision detection Voltage:
0.8V~1.9V: $\pm 0.8\%$
2.0V~6.0V: $\pm 0.5\%$
- Detection Voltage: 0.8V~6.0V (in 0.1V steps)
- Precise hysteresis
- Operating Voltage range: 0.7V~10V
- Ultra-low current consumption: 250nA typ. (at $V_{DD}=V_{TH}+1V$)
- Two Output forms : CMOS and N-channel open-drain

Application:

- Power monitor for portable equipment such as PDA, DSC, Mobile phone, Notebook, MP3
- CPU and Logic Circuit Reset
- Battery Checker
- Battery Back-up Circuit

Selection Guide:

8506D-XX X XX

Package Type:
 RM: SOT-23-3
 RN: SOT-23-5
 SM: SOT-89-3
 T: TO-92
 (Default, Pb Free)

Output Type:
 N: Nch Open-drain
 C: CMOS

Detector Voltage:
 09.....0.9V
 30.....3.0V

 50.....5.0V
 60.....6.0V

Pin Assignment:

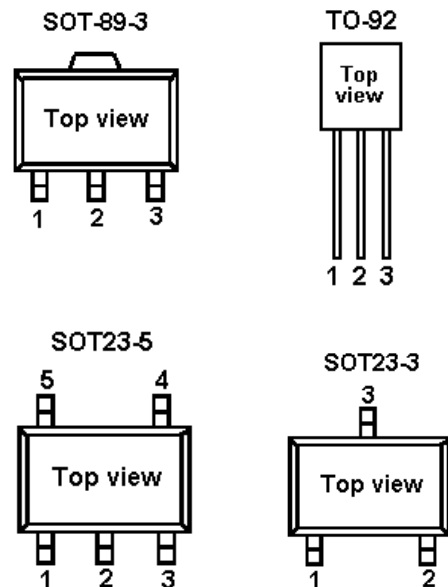

Pin Description:

PIN Number				PIN Name	Function
SOT-89-3	TO-92	SOT-23-3	SOT-23-5		
1	3	1	1	VOUT	Voltage detection output Pin
2	1	3	2	VDD	Voltage input Pin
3	2	2	3	VSS	GND Pin
—	—	—	4	NC	No connection
—	—	—	5	NC	No connection

Product Classification:

Product Name	Detector Voltage	Output Type	Package
BL8506D-XXNRM	XX V	Nch Open-Drain	SOT-23-3
BL8506D-XXNRN	XX V	Nch Open-Drain	SOT-23-5
BL8506D-XXNSM	XX V	Nch Open-Drain	SOT-89-3
BL8506D-XXNT	XX V	Nch Open-Drain	TO-92
BL8506D-XXCRM	XX V	CMOS	SOT-23-3
BL8506D-XXCRN	XX V	CMOS	SOT-23-5
BL8506D-XXCSM	XX V	CMOS	SOT-89-3
BL8506D-XXCT	XX V	CMOS	TO-92

Product Mark Information:

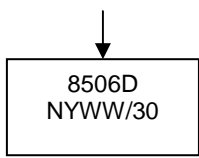
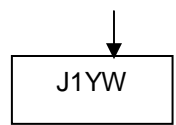
SOT-89-3 TO-92	SOT-23-5 SOT-23-3
Example: BL8506D-30NSM  8506D NYWW/30 Y: Year WW: Week	Example: BL8506D-30NRM  J1YW YW: Data Code

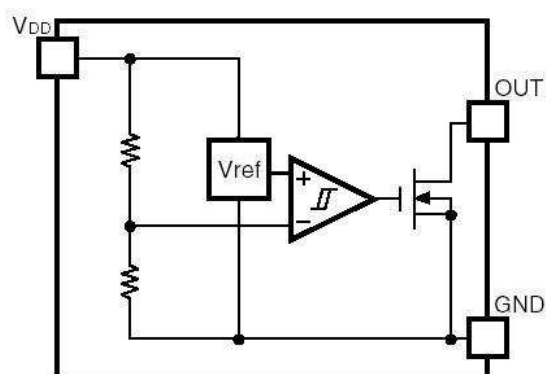
Block diagram:

N channel open-drain

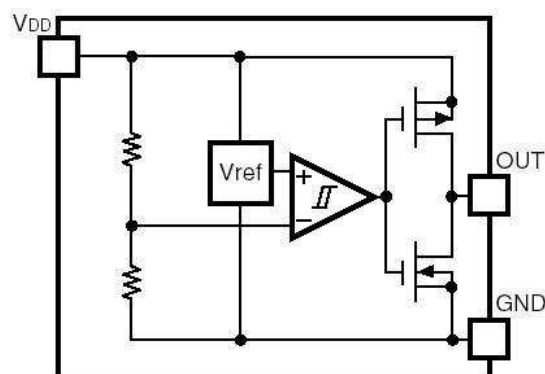

CMOS output

Absolute Maximum Ratings:

Parameter	Symbol	Rating	Unit
Supply Voltage	VDDmax	-0.3 ~ +12.0	V
Output Voltage	OUT	-0.3 ~ +12.0	V
Input Current	IDD	20	mA
Output Current	IOUT	20	mA
Power Dissipation	PD	150	mW
Operating Temperature	Topr	-40 ~ +105	°C
Storage Temperature	Tstg	-65 ~ +150	°C

Recommended Work Conditions:

Parameter	Symbol	Rating	Unit
Operating Temperature	Topr	-40 ~ +105	°C
Supply Voltage	VDD	+0.70 ~ +10.0	V

Electrical Characteristics:

(Typical values are at Ta=+25°C)

Parameter	Symbol	Test Condition	Rank	MIN.	TYP.	MAX.	Unit	Circuit
Reset Threshold	V _{TH}	上段 Ta=+25°C 下段 Ta=-40°C~+85°C	8208	0.7936	0.800	0.8064	V	2
				0.7800	-	0.8200		
			8209	0.8928	0.900	0.9072		
				0.8775	-	0.9225		
			8210	0.9920	1.000	1.0080		
				0.9750	-	1.0250		
			8211	1.0912	1.100	1.1088		
				1.0725	-	1.1275		
			8212	1.1904	1.200	1.2096		
				1.1700	-	1.2300		
			8213	1.2896	1.300	1.3104		
				1.2675	-	1.3325		
			8214	1.3888	1.400	1.4112		
				1.3650	-	1.4350		
			8215	1.4880	1.500	1.5120		
				1.4625	-	1.5375		
			8216	1.5872	1.600	1.6128		
				1.5600	-	1.6400		
			8217	1.6864	1.700	1.7136		
				1.6575	-	1.7425		
			8218	1.7856	1.800	1.8144		
				1.7550	-	1.8450		
			8219	1.8848	1.900	1.9152		
				1.8525	-	1.9475		
			8220	1.9900	2.000	2.0100		
				1.9500	-	2.0500		
			8221	2.0895	2.100	2.1105		
				2.0475	-	2.1525		
8222	2.1890	2.200	2.2110					
	2.1450	-	2.2550					
8223	2.2885	2.300	2.3115					
	2.2425	-	2.3575					
8224	2.3880	2.400	2.4120					
	2.3400	-	2.4600					
8225	2.4875	2.500	2.5125					
	2.4375	-	2.5625					
8226	2.5870	2.600	2.6130					
	2.5350	-	2.6650					
8227	2.6865	2.700	2.7135					
	2.6325	-	2.7675					
8228	2.7860	2.800	2.8140					
	2.7300	-	2.8700					

(Note2)

8229	2.8855	2.900	2.9145		
	2.8275	-	2.9725		
8230	2.9850	3.000	3.0150		
	2.9250	-	3.0750		

Parameter	Symbol	Test Condition	Rank	MIN.	TYP.	MAX.	Unit	Circuit
Reset Threshold (Note2)	V_{TH}	上段 Ta=+25℃ 下段 Ta=-40℃~+85℃	8254	5.3730	5.4000	5.4270	V	2
				5.2650	-	5.5350		
			8255	5.4725	5.5000	5.5275		
				5.3625	-	5.6375		
			8256	5.5720	5.6000	5.6280		
				5.4600	-	5.7400		
			8257	5.6715	5.7000	5.7285		
				5.5575	-	5.8425		
			8258	5.7710	5.8000	5.8290		
				5.6550	-	5.9450		
			8259	5.8705	5.9000	5.9295		
				5.7525	-	6.0475		
			8260	5.9700	6.0000	6.0300		
				5.8500	-	6.1500		
Reset Threshold Hysteresis	ΔV_{TH}	VDD=0V→VTH+1V→0V	8208	0.000	0.000	0.000	V	2
			8209	0.000	0.000	0.000		
			8210	0.000	0.000	0.000		
			8211	0.000	0.000	0.000		
			8212	0.000	0.000	0.000		
			8213	0.000	0.000	0.000		
			8214	0.000	0.000	0.000		
			8215	0.000	0.000	0.000		
			8216	0.000	0.000	0.000		
			8217	0.000	0.000	0.000		
			8218	0.000	0.000	0.000		
			8219	0.000	0.000	0.000		
			8220	0.000	0.000	0.000		
			8221	0.000	0.000	0.000		
			8222	0.000	0.000	0.000		
			8223	0.000	0.000	0.000		
			8224	0.000	0.000	0.000		
			8225	0.000	0.000	0.000		
			8226	0.000	0.000	0.000		
8227	0.000	0.000	0.000					
8228	0.000	0.000	0.000					
8229	0.000	0.000	0.000					
8230	0.000	0.000	0.000					
8231	0.000	0.000	0.000					

			8232	0.000	0.000	0.000		
			8233	0.000	0.000	0.000		
			8234	0.000	0.000	0.000		
			8235	0.000	0.000	0.000		
			8236	0.000	0.000	0.000		
			8237	0.000	0.000	0.000		
			8238	0.000	0.000	0.000		
			8239	0.000	0.000	0.000		
			8240	0.000	0.000	0.000		

Parameter	Symbol	Test Condition	Rank	MIN.	TYP.	MAX.	Unit	Circuit
Reset Threshold Hysteresis	ΔV_{TH}	VDD=0V→V _{TH} +1V→0V	8241	0.000	0.000	0.000	V	2
			8242	0.000	0.000	0.000		
			8243	0.000	0.000	0.000		
			8244	0.000	0.000	0.000		
			8245	0.000	0.000	0.000		
			8246	0.000	0.000	0.000		
			8247	0.000	0.000	0.000		
			8248	0.000	0.000	0.000		
			8249	0.000	0.000	0.000		
			8250	0.000	0.000	0.000		
			8251	0.000	0.000	0.000		
			8252	0.000	0.000	0.000		
			8253	0.000	0.000	0.000		
			8254	0.000	0.000	0.000		
			8255	0.000	0.000	0.000		
			8256	0.000	0.000	0.000		
			8257	0.000	0.000	0.000		
8258	0.000	0.000	0.000					
8259	0.000	0.000	0.000					
8260	0.000	0.000	0.000					
Supply Current	I _{DD}	VDD=V _{TH} +1V	8208~ 8260	—	0.25	1.0	μA	1
Reset Threshold Temp. Coefficient	$\Delta V_{TH}/^{\circ}C$ (Note2)	Ta=-40°C~+85°C	8208~ 8260	—	±100	—	ppm/ °C	2
L transfer delay time	(Note2) t _{PHL}	VDD=V _{TH} +0.4V→V _{TH} -0.4V (Note2)	8208~ 8260	2	15	100	μs	4
H transfer delay time	t _{PLH} (Note2)	VDD=V _{TH} -0.4V→V _{TH} +0.4V (Note2)	8208~ 8260	2	15	100	μs	4
"L" Output Current	I _{OL1}	VDD=0.7V, VDS=0.05V	8208~ 8260	0.01	0.10	—	mA	3

	I_{OL2}	VDD=1.2V, VDS=0.5V $V_{TH} \cong 1.3V$	8213~ 8260	0.23	2.00	—		
	I_{OL3}	VDD=2.4V, VDS=0.5V $V_{TH} \cong 2.5V$	8225~ 8260	1.60	8.00	—		
	I_{OL4}	VDD=3.6V, VDS=0.5V $V_{TH} \cong 3.7V$	8237~ 8260	3.20	12.0	—		
Output Leakage Current	I leak	VDD=10V, OUT=10V (IC-PST82XX series only)	8208~ 8260	—	—	0.1	μA	3

Test Circuit:

1)

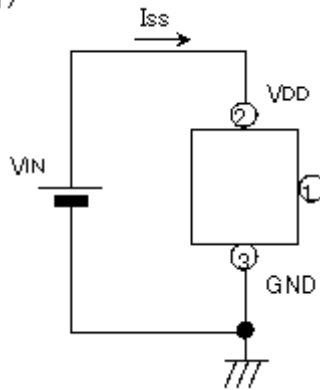

2)

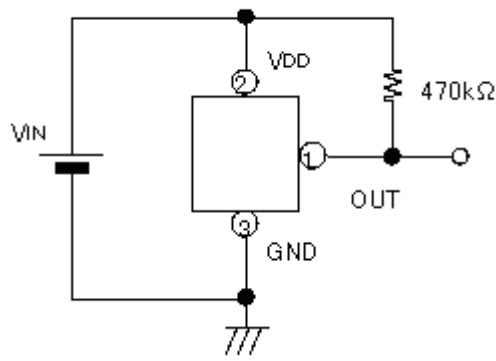

3)

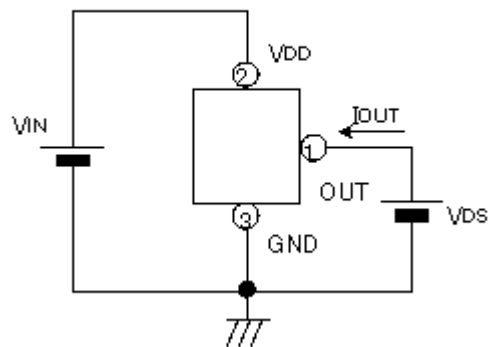

4)

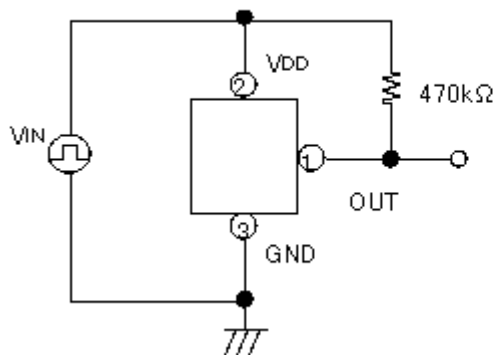

Input Voltage

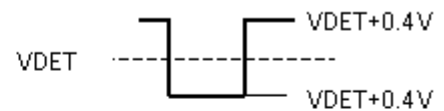

Output Voltage

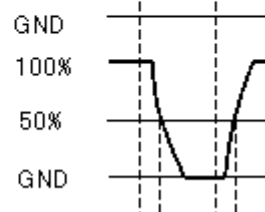

Timing Chart:

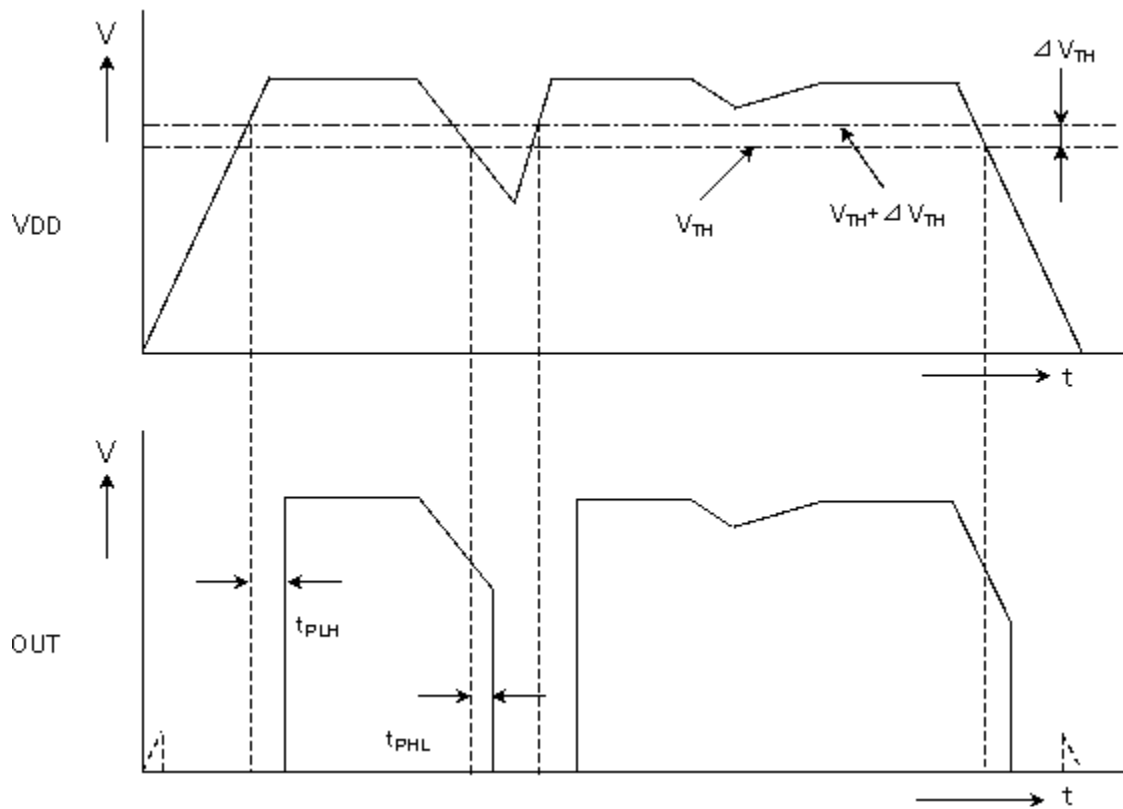

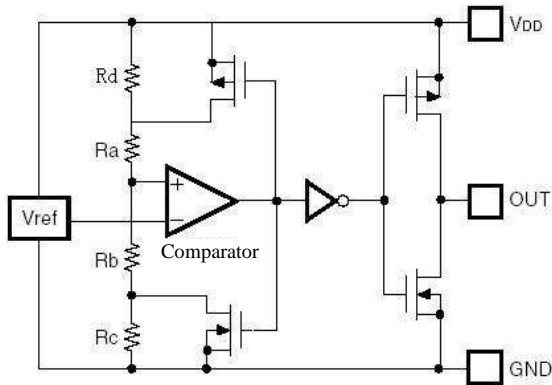
Function description:

High precision low temperature co-efficiency reference voltage is applied to the negative input of a comparator. Input voltage, divided by resistor array of Ra Rb and Rc, is applied to the positive input of the comparator. Output of the comparator controls a pair of NMOS and PMOS switches, generating the hysteresis. Output of the comparator passes a series of buffer to drive the output CMOS pair.

+ V_{DET}, - V_{DET}, V_{HYS} can be calculated as follows:

$$- V_{DET} = V_{REF} * (1 + R_a / (R_b + R_c))$$

$$+ V_{DET} = V_{REF} * (1 + (R_a + R_d) / R_b) = V_{REF} * (1 + (R_a + R_c) / R_b)$$

$$V_{HYS} = + V_{DET} - (- V_{DET}) = V_{REF} * (R_a + R_b + R_c) * (1 / R_b - 1 / (R_b + R_c))$$

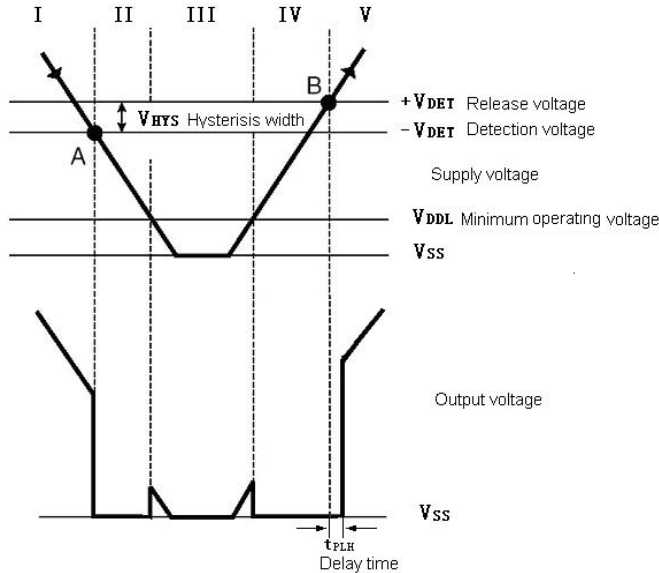

No.	Operation status	Output status
I	V _{DD} > -V _{DET}	Output voltage is equal to the supply voltage
II	V _{DD} drops below -V _{DET}	Output voltage equals to GND level
III	V _{DD} drops further below V _{DDL}	Output voltage is undefined
IV	V _{DD} rises above V _{DDL}	Output voltage equals to GND level
V	V _{DD} rises above +V _{DET}	Output voltage equals to supply voltage, V _{HYS} = (+V _{DET}) - (-V _{DET})

Typical Performance Characteristics:

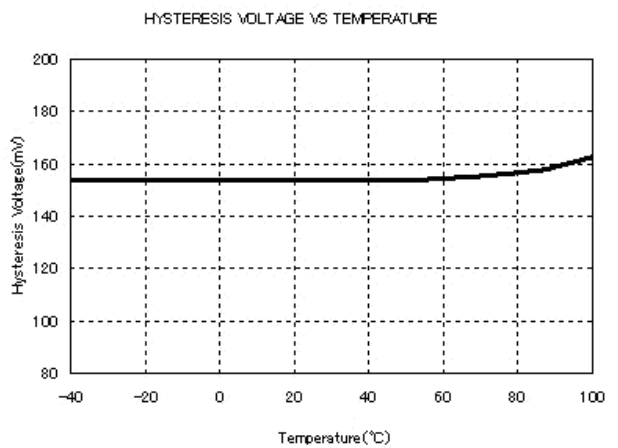
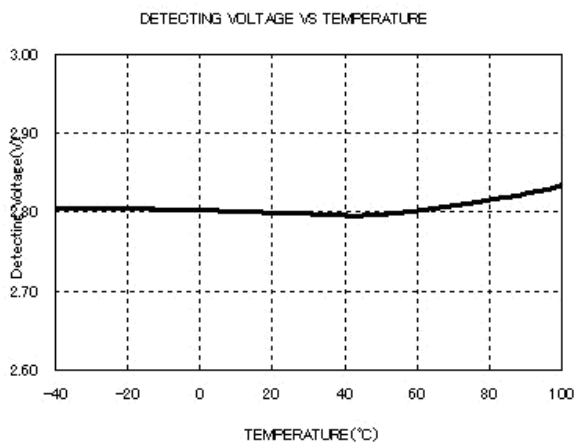
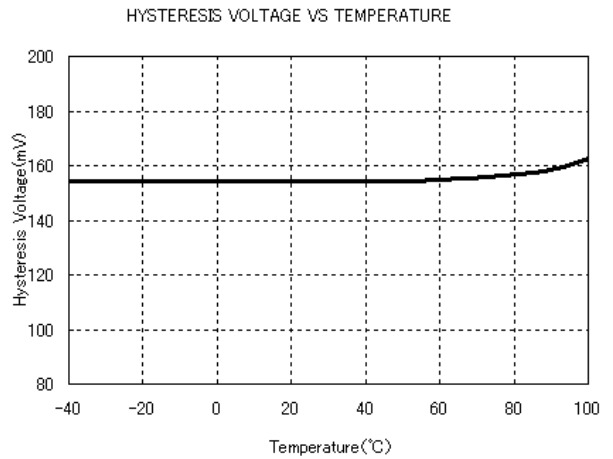
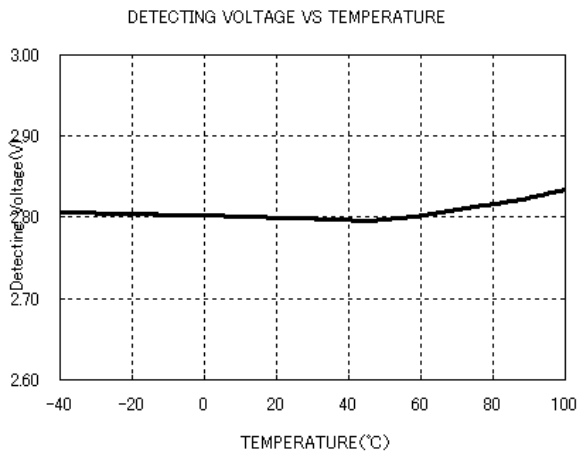
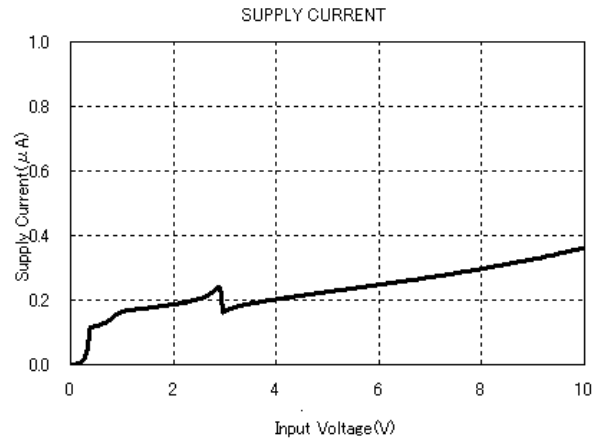
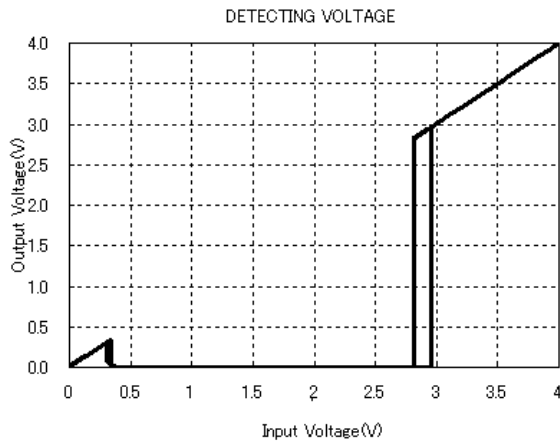

"L" OUTPUT CURRENT₃ VS TEMPERATURE

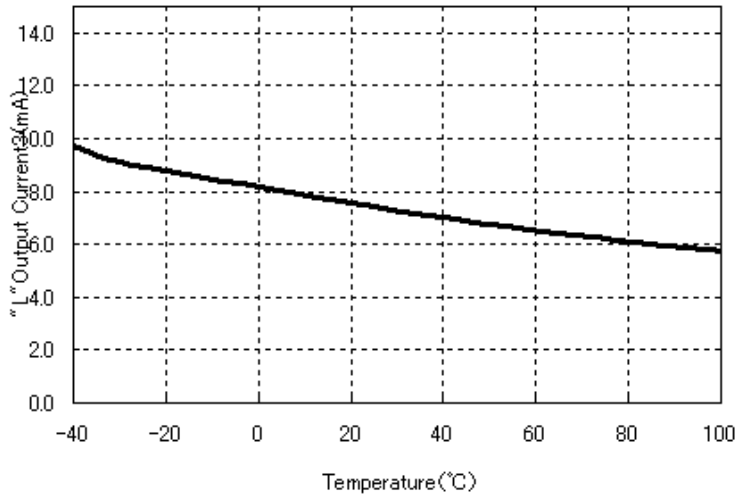

Typical applications:

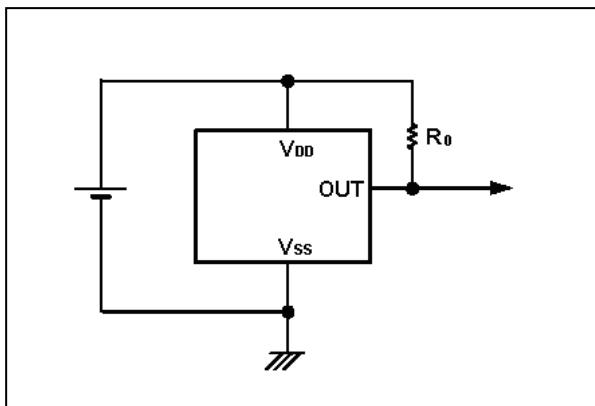
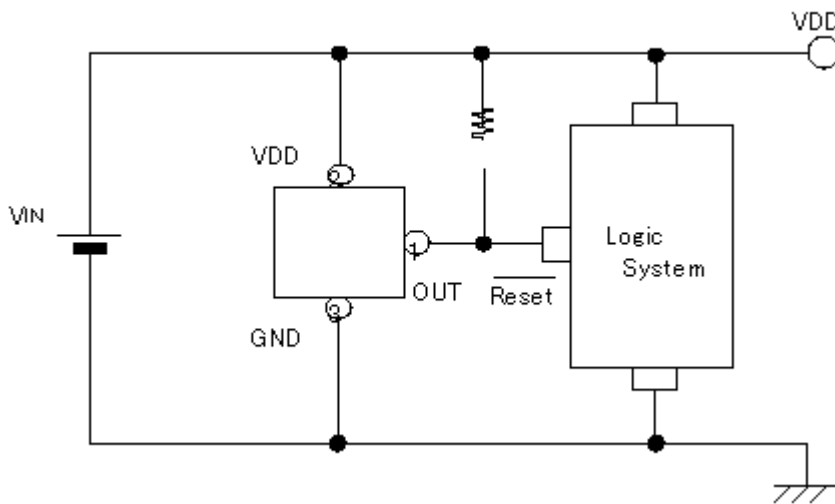

Note:

1. R_0 is unnecessary for CMOS output products.
2. The value of R_0 need to be selected in different application, Typical value is 470k Ω

Package Outline:
SOT-23-3:

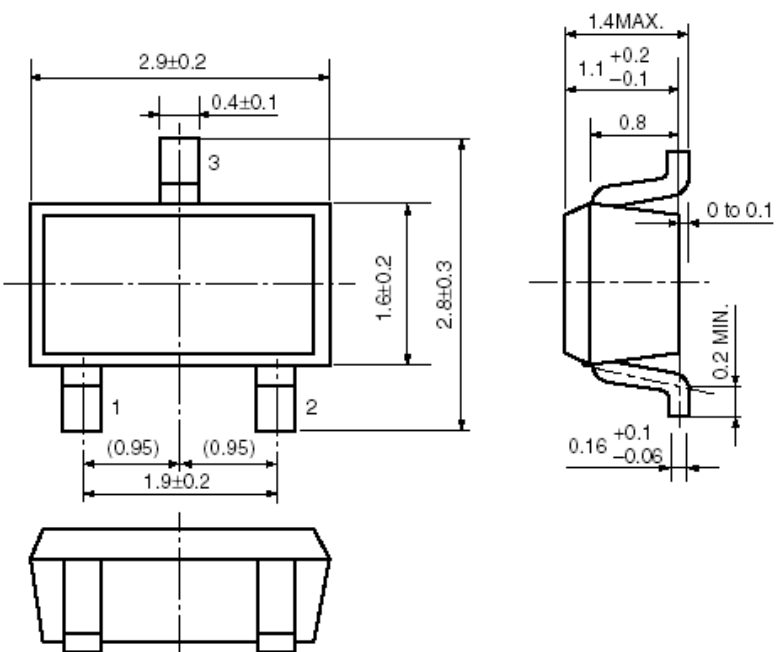
Package	SOT-23-3	Devices per reel	3000	Unit	mm
Package dimension: 					

SOT-23-5:

Package	SOT-23-5	Devices per reel	3000	Unit	mm
Package dimension: 